

Space Solar Power

THE FIRST INTERNATIONAL ASSESSMENT OF
SPACE SOLAR POWER: OPPORTUNITIES, ISSUES
AND POTENTIAL PATHWAYS FORWARD

John C. Mankins, Editor

International Academy of Astronautics



Notice: The cosmic study or position paper that is the subject of this report was approved by the Board of Trustees of the International Academy of Astronautics (IAA). Any opinions, findings, conclusions, or recommendations expressed in this report are those of the authors and do not necessarily reflect the views of the sponsoring or funding organizations. For more information about the International Academy of Astronautics, visit the IAA home page at www.iaaweb.org.

Copyright 2011 by the International Academy of Astronautics. All rights reserved.

The International Academy of Astronautics (IAA), a nongovernmental organization recognized by the United Nations, was founded in 1960. The purposes of the IAA are to foster the development of astronautics for peaceful purposes, to recognize individuals who have distinguished themselves in areas related to astronautics, and to provide a program through which the membership can contribute to international endeavors and cooperation in the advancement of aerospace activities.

© International Academy of Astronautics (IAA) August 2011. This publication is protected by copyright. The Information it contains cannot be reproduced without authorization.

Space Solar Power: The First International Assessment of Space Solar Power: Opportunities, Issues and Potential Pathways Forward

Edited by: John C. Mankins (USA) and
Nobuyuki Kaya (Japan)

Printing of this Study was sponsored by:
SPACECanada,
Toronto, Canada

International Academy of Astronautics
6 rue Galilée, BP 1268-16
75766 Paris Cedex 16, France



Code ISBN/EAN 978-2-917761-11-3

CONTENTS

ACKNOWLEDGMENTS

EXECUTIVE SUMMARY

1	INTRODUCTION	
1.1	Overview	1
1.2	The Global Energy/Environment Context	1
1.3	Brief History of the Solar Power Satellite Concept	6
1.4	The International Academy of Astronautics Study	8
1.5	Organization of this Report	13
2	SOLAR POWER SATELLITE SYSTEMS CONCEPTS	
2.1	SPS Design Reference Mission	15
2.2	Generic Solar Power Satellite Functional Architecture	17
2.3	Summary Evaluation of SPS Types Examined	19
2.4	Other Approaches to Space Solar Power	23
2.5	Solar Power Satellite Systems Trade Space Summary and Assessment	32
3	SPS SUPPORTING SYSTEMS	
3.1	Earth-to-Orbit Transportation	35
3.2	In-Space Transportation	42
3.3	Space Assembly, Maintenance and Servicing	46
3.4	Ground Energy and Interface Systems	47
3.5	In-Space Resources and Manufacturing	49
3.6	SPS Supporting Systems Trade Space Summary and Assessment	52
4	TECHNOLOGY READINESS AND RISK ASSESSMENT	
4.1	Technology Readiness and Risk Assessment Methodology	55
4.2	Identification of Key Technology Areas for Assessment	57
4.3	SPS Concept-Specific Technologies	57
4.4	Platform Generic Technologies	61
4.5	Key SPS Supporting Systems Technologies	62
4.6	Technology Readiness and Risk Assessment Summary	64
5	SSP / SPS POLICY AND OTHER CONSIDERATIONS	
5.1	General Policy, Legal and Regulatory Considerations	69
5.2	Specific SSP / SPS Policy Considerations	74
5.3	Other Considerations: Space Applications	85

IAA STUDY OF SPACE SOLAR POWER

5.4	Other Considerations: Terrestrial Benefits	90
5.5	Summary	91
6	SPS MARKET ASSESSMENT AND ECONOMICS	
6.1	Past SPS Market and Economic Studies	94
6.2	Framing the Question of SSP: Strategic Global Scenarios	95
6.3	SPS Market and Economics Assessment	102
6.4	Summary	104
7	PRELIMINARY SYSTEMS ANALYSIS RESULTS	
7.1	Systems-Technology Considerations	107
7.2	Key Figures of Merit	125
7.3	Preliminary Cost Analysis: Limits Analysis Approach	126
7.4	Space Solar Power “Zones of Interest”	142
7.5	R&D Goals and Objectives	143
7.6	Analysis and Evaluation of Selected Types of SPS	144
7.7	Summary	149
8	AN INTERNATIONAL ROADMAP FOR SPACE SOLAR POWER	
8.1	Roadmap Approach	151
8.2	Preliminary International Roadmap for Space Solar Power	152
8.3	Studies and Basic Technology Research	154
8.4	Technology Flight Experiments and R&D	155
8.5	Systems-Level Technology Demonstrations	157
8.7	Pilot Plant(s) and Space Applications	157
8.8	Operational Solar Power Satellite(s)	159
8.9	Summary	159
9	CONCLUSION: FINDINGS AND RECOMMENDATIONS	
9.1	Summary of Study Findings	161
9.2	Recommendations for the International Community	165
9.3	Concluding Remarks	168

APPENDICES

Appendix A	Glossary of Acronyms	171
Appendix B	IAA Study Participants	177
Appendix C	IAA Study Terms of Reference	181
Appendix D	Solar Power Satellite Systems Concepts: Detailed Descriptions	185
Appendix E	Technology Readiness and Risk Assessment Details	217
Appendix F	Systems Analysis Methodology	235
Appendix G	A Selection Of Past WPT Tests (Ground And Flight)	237
Appendix H	Comparison of Demand Load and Ground Renewable Energy	239
Appendix I	References	243

ACKNOWLEDGMENTS

This study was conducted under the auspices of the International Academy of Astronautics' (IAA) Commission III (Space Technology & System Development), and benefited from review and comments by numerous members of the Academy, and members of the Commission.

The study could not have been completed without the timely and valuable efforts of a diverse collection of international experts who contributed their time and provided technical material for the study, including the members of the IAA Study (whose names are provided in Appendix B), and especially the co-Chair of the Study, Prof. Nobuyuki Kaya of Kobe University. The contributors included personnel from space agencies, commercial firms, universities, and non-profit organizations.

Thanks are also due to the members of the International Academy of Astronautics peer review committee who provided highly useful comments on an initial draft of this report.

Special thanks are due to SPACECanada for co-hosting and supporting the SPS 2009 International Symposium and Workshop on Space Solar Power, held at the Ontario Science Center in Toronto, Canada in September 2009, and for generously supporting the publication of the study final report.

Thanks are also due to the FATE Consortium for its support for the SPS 2009 International Symposium and Workshop.

And finally, thanks are due to the many individuals who attended the SPS 2009 meeting and provided valuable inputs to the work of the IAA study.

EXECUTIVE SUMMARY

It is crucial for the world to identify, research, develop, demonstrate, commercialize and deploy affordable and sustainable new energy sources. This need is driven by various factors; three of the most important are: (1) demand for energy to enable economic growth for a still-increasing global population, (2) concerns regarding the long-term accumulation in Earth's atmosphere of fossil fuel-derived greenhouse gases, and (3) the prospect that during the coming decades annual production of petroleum (and possibly other fossil fuels) will peak and begin to decline.

Continuing economic progress will require a four-fold increase in annual energy use by the end of the century. If carbon dioxide (CO₂) emissions into the atmosphere are to be constrained during the same span, by 2100 some 90% of all energy used must be from renewable or nuclear sources. Notwithstanding optimistic claims to the contrary, it does not appear that there is at present a solution to these concurrent challenges.

Substantial renewable energy now comes from hydropower sources, and a much smaller amount from geothermal power; however, these remain a modest fraction of the total. Also, a wide variety of aerospace technologies – including photovoltaic arrays, fuel cells, and wind turbines – have been applied during the past three decades in newer renewable energy systems. Certainly, these already-existing “green” technologies can be expected to make substantial contributions to meeting long-term energy challenges faced by the global economy. However, these technologies are unlikely to provide the huge amounts of new and sustainable energy that will be needed in the coming decades.ⁱ

In the late 1960s, Dr. Peter Glaser of Arthur D. Little invented a fundamentally new approach to global energy: the Solar Power Satellite (SPS). The basic concept of the SPS is quite elegant: a large platform, positioned in space in a high Earth orbit continuously collects and converts solar energy into electricity. This power is then used to drive a wireless power transmission (WPT) system that transmits the solar energy to receivers on Earth. Because of its immunity to nighttime, to weather or to the changing seasons, the SPS concept has the potential to achieve much

greater energy efficiency than ground based solar power systems (in terms of utilization of fixed capacity).

The SPS concept has been the subject of numerous national systems studies and technology development efforts during the 40 years from 1970 to 2010. These have included several intense, but episodic efforts in the US, Canada and Europe, as well as steady technology research and development (R&D) activities in Japan, and recent activities in China and India. There have also been a number of national and international conferences, workshops and symposia addressing the SPS concept. Despite these activities, up until the past several years, there has never been a comprehensive international assessment of the SPS concept.

The IAA Study of Space Solar Power

The International Academy of Astronautics (IAA) has conducted the first broadly based international study of the concept of space solar power.¹ This assessment was conducted under the auspices of IAA Commission 3 (Space Technology & System Development) and involved participants from the Academy, a wide variety of other organizations, and diverse countries. The goals of the study were to determine what role space solar power (SSP) might play in meeting the rapidly growing need for abundant and sustainable energy during this century, to assess the technological readiness and risks associated with the SSP concept, and (if appropriate) to frame a notional international roadmap that might lead to the realization of this visionary concept.

Because significant advances in space solar power could have profound benefits for human and robotic space exploration capabilities as well as other space applications, the study also identified such opportunities and evaluated the potential for synergies (if any) between these benefits for space missions and space solar power for terrestrial markets. Finally, there have long been discussions of the potential role that extraterrestrial resources might play in solar power satellite architectures; as a result, the study attempted to identify these opportunities and assess potential

¹ There was a partial assessment (c. 2006) performed by URSI (*Union Radio Scientifique Internationale*), however the emphasis was on wireless power transmission and potential impacts of SPS on radio science. (See K. Hashimoto, "URSI White Paper on Solar Power Satellite (SPS) Systems" (September 2006).

connections between international lunar exploration programs now being undertaken and SSP systems.

Study Results Summary²

The following paragraphs briefly summarize the key results of the study, organized by the individual chapters.

Solar Power Satellite Systems Concepts (Chapter 2; SG2)

Three highly promising SPS platform concepts were examined in some detail by the IAA study; the results of this examination provide a framework for the remainder of the report, including the technology assessment, market assessment, etc. All three of the cases examined were geostationary Earth orbit-based SPS concepts; these were: (1) an updated version of the microwave wireless power transmission (WPT) 1979 SPS Reference System concept, involving large discrete structures (e.g., solar array, transmitter, etc.) assembled by a separate facility in space; (2) a modular electric / diode array laser WPT SPS concept, involving self-assembling solar power-laser-thermal modules of intermediate scale; and (3) a extremely modular microwave WPT SPS “sandwich structure” concept, involving a large number of very small solar power-microwave-thermal modules that would be robotically assembled on orbit. Several alternative SSP concepts were also identified but not analyzed, including the low Earth orbit-based “SunTower” SPS concept, lunar solar power, and others.

The three SPS concept types examined by the IAA span effectively a wide range of SSP architecture choices and options. These several systems types include a number of similarities and differences, depending on the specific topic of interest within the trade space.

As a result of its assessment, the IAA concurs with the findings of previous groups, including the US National Academy of Sciences: Solar Power Satellites are technically feasible. There are no fundamental technical barriers that would prevent the realization of large-scale SPS platforms during the coming decades. However, as noted, questions remain as to the economic viability of SPS. An early result of the IAA study evaluation of the SPS trade space was the selection of only three basic

² The summary results of the study sketched here are keyed to (a) the specific objectives of the study group (see Chapter 1 for detailed statement of study objectives, and for the key defining SG1, SG2, etc.); and (b) to the several Chapters of the report.

systems types for detailed examination. The overall results of the study suggest that this early decision was appropriate; however, alternative SPS systems / architecture concepts may warrant future consideration.

SPS Supporting Systems (Chapter 3; SG2, SG4)

There are a number of extremely important systems other than the SPS platform itself that must be pursued to provide essential support for the development and operation of SPS platforms. The supporting systems that were examined included (1) Earth-to-orbit (ETO) transportation; (2) affordable in-space transportation; (3) space assembly, maintenance and servicing; and, (4) ground energy and interface systems. A longer term supporting system option was also examined: (5) in-space resources and manufacturing.

The three SPS concept types examined together would involve a wide variety of supporting system choices and options. These systems include a range of similarities and differences, depending on the specific topic of interest within the trade space. As in the case of the SPS platform itself, the IAA found that there are no fundamental “show-stoppers” among the required supporting systems (i.e., no technical barriers that would prevent the realization of large-scale SPS platforms during the coming decades). However, as noted, there are key challenges in achieving the very low cost operations needed to achieve economically viable SPS. The most critical of these was the essential requirement for very low cost ETO transport.

Technology Readiness and Risk Assessment (Chapter 4; SG2, SG7)

A summary assessment was developed of the key technologies required for primary candidate SPS platform types and the associated supporting systems. This technology readiness and risk assessment (TRRA) provides the basis for the subsequent R&D roadmap (Chapter 8). The approach used to implement the TRRA was based on the technology readiness level (TRL) scale (developed by NASA in the 1970s), augmented by formal considerations of the expected research and development (R&D) degree of difficulty (R&D3), and a judgment of the systems-level importance of a particular technology advancement to a given SPS type.

The TRRA results are summarized in Chapter 4 (Table 4-2, Table 4-3 and Table 4-4). Overall, it was found that the updated 1979 SPS Reference System is the highest risk and lowest readiness option, while the highly modular microwave “sandwich structure” SPS was the lowest risk and

highest readiness. The modular electric laser SPS option was in-between the two microwave concepts. The technology readiness and risk assessment performed was highly simplified due to the scope of the overall study; a more rigorous assessment requires a detailed systems analysis of various SPS platform options, as well as various supporting systems (e.g., ETO transportation).

SSP / SPS Policy and Other Considerations (Chapter 5; SG1, SG6)

The IAA examined various important policy, regulatory and legal considerations vis-à-vis SPS. One such topic is that of spectrum allocation: working through the international community of interest to secure a portion of the electromagnetic spectrum that might be used for wireless power transmission. Another topic of importance is that of identifying strategies for international coordination and cooperation in SPS development and operations.

Some of the important policy considerations examined included (1) the overall international regime (e.g., the Outer Space Treaty) that will comprise the framework for space solar power development; (2) various international legal requirements (e.g., the ITU, and space debris mitigation guidelines) with which SPS must comply; and, (3) relevant national legislation and regulations (such as ITAR in the US and similar rules in other countries).

Detailed topics examined included (1) WPT beam health and safety considerations; (2) WPT spectrum allocation and management; (3) space debris considerations; and, (4) potential weaponization concerns. None of these factors appears to be insurmountable for SPS R&D eventual deployment. However, each of these (and others) will require appropriate attention during the early phases of SPS development. This is particularly true with respect to issues related to WPT beam safety and possible weaponization.

Finally, it is clear that the development of SSP technologies and systems could yield significant benefits for a wide range of non-SPS applications – in space and on Earth. Some of the novel future space applications of space solar power technologies include: power beaming to a lunar or Mars outpost from an orbital power plant; high-power solar electric power and propulsion for Earth-Moon and interplanetary transportation; and, the enabling of revolutionary new space capabilities such as robotic in-space assembly, maintenance and servicing, modular

communications satellites, and others. Novel classes of Earth orbiting satellites and terrestrial applications of SSP technologies would likely also result.

SPS Market Assessment and Economics (Chapter 6; SG1, SG5)

In looking toward rest of this century, it is obviously impossible to predict with confidence how the many issues that will frame the market for SPS will unfold. In order to provide a reasonable, but not exhaustive framework, the IAA identified four strategic scenarios for the future that would greatly affect potential SSP/SPS markets and economics. These were: (1) Scenario Alpha – “Business as Usual Works Out” (i.e., conventional and/or available renewable energy sources prove to be capable of meeting future demand, and no adverse changes occur in Earth’s climate); (2) Scenario Beta – “The Frog Gets Cooked” (i.e., the global economy does not deploy massive new renewable sources, and dramatic negative changes in Earth’s climate result); (3) Scenario Gamma – “Fossil Fuels Run Out” (i.e., the global economy does not deploy massive new renewable sources and peak oil, peak gas and peak coal occurs sooner than expected); and, (4) Scenario Delta – “Green Policies Work” (i.e., the deployment of new renewable energy sources is accelerated and succeeds in forestalling changes to Earth’s climate result).

Each of the four Scenarios described was intended to capture a particular possible aspect of the future – and to provide a tangible context for laying out more detailed architectures and concepts-of-operations for future Solar Power Satellites. Specific architectures for SPS (e.g., lower cost, larger-scale RF systems versus high-cost, smaller-scale laser systems) may then be compared in terms of their potential to meet the energy requirements of the several Scenarios. The characterizations of possible future energy costs presented here **are not** intended as literal / quantitative forecasts; instead they are formulated to suggest what sorts of SPS systems might be more or less profitable depending on the Scenario in question.

Based on these cases, the most dramatic increases in the cost of primary baseload power might be expected in the later term if available supplies of key fossil fuels begin to drop behind market demand earlier in this century rather than later. However, strong “green energy” policies could lead to the most favorable nearer-term environment in such primary markets. These policies would result in higher prices in the nearer term, but avoid the market risks of either fossil fuel depletion earlier than hoped

(Scenario Gamma) or significant climate change (Scenario Beta) in the mid-to-latter half of the century.

In all cases, premium niche markets (PNMs) that may command higher prices for energy represent attractive options for space solar power. Remote and/or leveraged commercial markets appear particularly attractive in all cases, but especially in the case of Scenario Gamma (“Fossil Fuels Run Out”) in which conventional fuels are depleted, but no special preparations are made early enough to offset the resulting energy price increases.

Preliminary Systems Analysis Results (Chapter 7; SG2, SG5)

Although the scope of the IAA study did not permit detailed modeling of the SPS concept, nevertheless some highly preliminary systems analyses could be conducted using high level relationships and selected aspects of the physics that will bound the engineering challenges to be resolved. Using this methodology, the IAA conducted analyses of various SPS, and supporting systems options. The set of systems-technology considerations ranged from the physics of wireless power transmission to thermal management, from ETO launch capability to impacts of using expendable versus reusable vehicles. Some of the key SPS figures of merit (identified in Chapter 6) also were examined.

As a result, selected strategic and more detailed goals for future SSP technology R&D were identified. Each of the three SPS concepts were assessed in terms of these systems-technology considerations. At the end, it appeared that there are clear advantages for more modular, higher end-to-end efficiency systems concepts – particularly for large-scale commercial baseload power. And, the highly modular microwave WPT sandwich SPS concept appears the most attractive overall.

However, it is clear that additional, more analytically rigorous systems analysis studies are needed to better characterize the complex systems-technology-market issues that space solar power entails.

International SPS Strategic Roadmap (Chapter 8; SG8)

The IAA synthesized a high-level roadmap for SSP/SPS that details a prospective path forward for the international space and energy community. This road map reflects the belief that several iterative stages of systems study and focused technology R&D will be necessary to enable the

deployment of economically viable solar power satellites. The roadmap comprises several types of activities including:

- SSP Advanced Systems Studies and Basic Technology Research;
- SSP-Relevant Technology Research and Development;
- SSP Sub-System & Component-Level Technology Flight Experiments;
- Major Sub-System / System-Level Technology Demonstrations (including both Ground and Flight demonstrations);
- Design, Development & Demonstrations of SSP Systems (including SPS Pilot Plants, Supporting Infrastructures, Secondary Space Applications, and Terrestrial Spin-Offs); and,
- Solar Power Satellite Development, Deployment and Operations

A broad range of technical challenges must be addressed in order to establish the economic feasibility of SPS, and – if appropriate – to subsequently proceed with their development. It is possible that a single government or major company might surmount these challenges. However, it seems more likely that timely success would result from cooperation in accomplishing R&D objectives among governments, among industry players and among a broad range of government, corporate and academic organizations.

A variety of tests and demonstrations of one key SPS technology – wireless power transmission – have been performed since the 1960s. Many of these tests have involved component technologies that are not directly relevant to validating the economic viability of SSP. Moreover, selected early demonstrations have been performed by various organizations almost as a means of “getting their feet wet” – i.e., in learning the basics of WPT and/or SPS. Unfortunately, the next steps in moving higher in the TRL scale require considerably greater funding (i.e., from the lower left to the upper right in the roadmap); these key steps have not yet been taken.

Timely communication of plans and results from SPS technology R&D activities is crucial to coordinated progress. The ongoing Power Symposium, organized annually at the International Astronautical Congress (IAC), has served a highly useful role in this regard. Similarly, periodic conferences dedicated to SPS and WPT have been held over the past 20+ years in various countries (e.g., WPT 1995, SPS 2004, etc.); these have been

highly useful in promoting international dialog and coordination of SSP efforts.

As noted above, it was the consensus of the IAA that SSP systems are technically feasible. However, the successful development of the SPS concept – and the determination of markets might be served economically – cannot be accomplished without investments in systems-level, end-to-end studies, ground and flight demonstrations at higher TRL levels, and eventually the launch of major sub-scale SPS pilot plant demonstrations.

The preliminary international roadmap for SSP is not highly specific – it does not prescribe a specific budget, nor does it involve a specific schedule. However, it does provide a tractable framework for future SPS related activities by indicating a logical sequence for various steps, and the conceptual relationships among those steps. Moreover, it is the consensus of the IAA that significant progress could be accomplished during the next 10-15 years – leading to a large, but sub-scale SPS pilot plant.

Based on the above results, the IAA Study formulated the findings and recommendations presented below.

Findings and Recommendations

Overview

The successful development and market-competitive deployment of any major new energy technology requires decades to accomplish. Historical examples include coal, oil, electricity, natural gas, etc. It is likely that space solar power (SSP) will be no different. As noted, the original invention of SPS occurred in the late 1960s, and the advancement of specific (e.g., wireless power transmission) and relevant technologies (e.g., reusable launch vehicles) has continued during the subsequent 40 years. As of 2010, the fundamental research to achieve technical feasibility for the SPS was already accomplished. Whether it requires 5-10 years, or 20-30 years to mature the technologies for economically viable SPS now depends more on (a) the development of appropriate platform systems concepts, and (b) the availability of adequate budgets. Based on the results of the IAA assessment of the concept of solar energy from space, the International Academy of Astronautics makes the following findings and offers the associated recommendations regarding the concept of future space solar power for markets on Earth.

Findings

Finding 1: Fundamentally new energy technologies clearly appear to be needed during the coming decades under all examined scenarios – both to support continued (and sustainable) global economic growth, and for reasons of environmental/climate concerns. Solar energy from space appears to be a promising candidate that can contribute to address these challenges.

Finding 2: Solar Power Satellites appear to be technically feasible as soon as the coming 10-20 years using technologies existing now in the laboratory (at low- to moderate- TRL) that could be developed / demonstrated (depending on the systems concept details).

- **Finding 2a:** There are several important technical challenges that must be resolved for each of the three SPS systems types examined by the IAA study.
- **Finding 2b:** The mature (high-TRL) technologies and systems required to deploy economically viable SPS immediately do not currently exist; however, no fundamental breakthroughs appear necessary and the degree of difficulty in projected R&D appears tractable.
- **Finding 2c:** Very low cost Earth to orbit transportation is a critically needed supporting infrastructure in which new technologies and systems must be developed to establish economic viability for commercial markets.

Finding 3: Economically viable Solar Power Satellites appear achievable during the next 1-3 decades, but more information is needed concerning both the details of potential system costs and the details of markets to be served.

- **Finding 3a.** SPS do appear economically viable under several different scenarios for future energy markets, including potential government actions to mediate environment/climate change issues.
- **Finding 3b.** The economic viability of particular Solar Power Satellite concepts will depend upon both the markets to be served, and the successful development of the technologies to be used (including required levels of performance (i.e., key figures of merit for SPS systems).
- **Finding 3c:** The potential economic viability of SPS has substantially improved during the past decade as a result of the emergence both of

government incentives for green energy systems, and of “premium niche markets”.

- **Finding 3d.** Establishing the economic viability of SPS will likely require a step-wise approach, rather than being achieving all at once – in particular SPS platform economics, space transportation economics, in-space operations economics, integration into energy markets, etc., will likely require iterative improvements to build confidence and secure funding for further developments.
- **Finding 3e.** Given the economic uncertainties in developing and demonstrating SPS technologies and systems and the time required, it is unlikely that private sector funding will proceed alone; i.e., government involvement and funding support is likely needed.

Finding 4: An in-depth end-to-end systems analysis of SSP/SPS is necessary to understand more fully the interactions among various systems / technologies for different concepts and markets; however, no such study has been performed since the conclusion of NASA’s Fresh Look Study in 1997.

- **Finding 4a:** Scenario-based study approaches can be extremely useful in examining prospective markets for visionary future systems such as SPS, but must provide sufficient detail to enable one to distinguish from among various SPS systems options.
- **Finding 4b:** Special attention appears needed to refresh understanding of prospects for space applications of SSP systems and technologies, with attention to the enabling role that low-cost electrical power in roughly the megawatt range could play for ambitious future space missions and markets.

Finding 5: Low-cost Earth-to-orbit transportation is an enabling capability to the economic viability of space solar power for commercial baseload power markets.

- **Finding 5a:** Extremely low cost ETO transportation systems appear to be technically feasible during the coming 20-30 years using technologies existing in the laboratory now (at low- to moderate- TRL) that could be developed / demonstrated (depending on the systems concept details). However, the technologies required for this future space capability are not sufficiently mature for system development to begin at present.

- **Finding 5b:** Acceptable ETO systems for future SPS must be “environmentally benign” – i.e., space transportation infrastructures to launch the satellites cannot result in harmful pollution of the atmosphere.

Finding 6: Systems studies are not enough. Technology Flight Experiments (TFEs) to test critical technology elements and Technology Flight Demonstrations (TFD) that validate SPS systems concepts to a high level of maturity (“TRL 7”³) appear to be essential in order to build confidence among engineers, policy makers, and the public and allow space solar power technology maturation and SPS deployment to proceed.

- **Finding 6a:** The International Space Station (ISS) appears to represent a highly attractive potential platform at which various SSP and related technology flight experiments (TFEs) could be performed.
- **Finding 6b:** Free flying spacecraft appear to be an attractive option for selected SSP TFEs and systems level demonstrations.

Finding 7: Architectural approaches that most efficiently and seamlessly integrate energy delivered from SPS into existing terrestrial energy networks are likely to be the most successful. (The same is true for any transformational new energy technology.)

Finding 8: The SPS concept is sufficiently transformational and entails enough technical uncertainties such that major systems level in-space demonstrations will be necessary to establish technical feasibility, engineering characteristics and economical viability before any organization is likely to proceed with full-scale development.

- **Finding 8a.** The likely investment in technology maturation, hardware development and system deployment for a very low-cost, highly reusable space transportation (HRST) system will require some 10s of billions of dollars (\$, US). If the SPS concept is the sole – or even a significant – market justification for such a development, then it is likely that a large-scale, pilot plant type demonstration of the SPS to be launched will be required prior to a government and/or commercial commitment to fielding HRST systems or supporting infrastructure.
- **Finding 8b.** In-space systems and infrastructures that will support SPS deployment, assembly, servicing, etc. will be intimately related to the detailed designs and characteristics of the SPS platform, and to the design of supporting ETO systems (see Finding above). Such in-space

³ “TRL” refers to the “technology readiness level” scale; see Appendix E.

systems will likely need to be developed and demonstrated in tandem with, if not prior to, the implementation of an SPS pilot plant demonstration.

Finding 9: A variety of key policy-related and regulatory issues must be resolved before systems-level demonstrations – particularly space based tests – of SPS and WPT can be implemented.

- **Finding 9a.** Spectrum management is an issue of particular importance that must be addressed early due to the time-consuming international processes that are in place vis-à-vis use of the electromagnetic spectrum and orbital slot allocations.
- **Finding 9b.** A number of operational issues that are related to international cooperation and coordination, including WPT transmission safety requirements, orbital debris generation and management, etc., must also be addressed early.
- **Finding 9c.** Policy related and regulatory issues will require considerable time to resolve, making the need to begin discussions in a timely way very pressing, particularly for SPS and related technology in-space tests and demonstrations.

Recommendations

Based on the results of the IAA assessment of the concept of space solar power, the Academy offers the following recommendations for the consideration of the international community.

Recommendation 1: Both government-supported and commercially funded SSP systems analysis studies should be undertaken that have sufficient end-to-end breadth and detail to fully resolve the R&D goals and objectives that must be achieved to establish the viability of SSP.

- **Recommendation 1a:** Where possible, SSP and related systems analysis studies recommended should be coordinated among various countries and between industry and government agencies.
- **Recommendation 1b:** It is recommended that focused and rigorous market studies should be included in future integrated /end-to-end SPS systems studies; a scenario-based approach should be considered as a key element of such studies. In addition, such studies should include more detailed analysis of “premium niche markets” in various countries and/or for specific customers.

- **Recommendation 1c:** Future systems analysis / market studies should examine explicitly the potential integration of SPS / WPT concepts into existing (or projected) terrestrial energy networks. These studies should involve additional non-aerospace sector experts (for example, from the energy and utility sectors).
- **Recommendation 1d:** Future systems studies should examine in greater detail the comparison of SPS with other energy technologies for various market opportunities, including both nearer-term technologies (such as ground solar) and farther term technologies (such as fusion).
- **Recommendation 1e:** Future systems studies should address a range of detailed issues, including policy and economic considerations, GEO orbital slot availability, operational issues (e.g., in-space assembly / infrastructure, SPS reliability and failure considerations), and orbital debris. These studies should examine Earth-to-orbit and in-space transportation issues carefully.
- **Recommendation 1f:** Future systems studies should place appropriate emphasis on better life cycle cost (LCC) estimates of SPS, including examining the impact of new models of large volume production of space systems.

Recommendation 2: Future economic analyses should examine the potential role of non-space related government and international funding agencies in contributing to the development of SPS.

Recommendation 3: Government and commercial organizations should consider undertaking SSP and related technology R&D, including platform systems and supporting infrastructures (e.g., ETO, in-space transportation, in-space operations).

- **Recommendation 3a:** The International Space Station (ISS) should be considered as a potential platform on and from which a number of useful SSP and related technology flight experiments and tests could be performed.
- **Recommendation 3b:** Specific space solar power technology R&D activities – such as ground demonstrations and technology flight experiments – should be planned so as to best advance the overall state-of-the-art for SSP, and the results communicated as broadly as possible (consistent with restrictions due to intellectual property or government regulations).

- **Recommendation 3c:** It is recommended that as studies and technology R&D go forward that are directed toward SPS, WPT and related applications, there should be supporting research concerning WPT health and safety issues.
- **Recommendation 3d:** SSP technology development efforts should explicitly seek prospective nearer-term applications in support of international space goals and programs, such as space exploration.
- **Recommendation 3e:** Where possible, governments and commercial sector players should consider the formation of public-private partnerships to implement SSP technology development efforts; government agencies in particular should take steps to enable to encourage the formation of such partnerships.

Recommendation 4: The necessary policy and regulatory steps to enable SPS/WPT and related R&D to be conducted – leading to systems-level demonstrations – should be undertaken in the near term by government, commercial and other interested organizations.

- **Recommendation 4a:** It is recommended that particular attention should be paid to the allocation of spectrum for WPT technology development efforts and later system applications.
- **Recommendation 4b:** It is recommended that the formation of Public-Private Partnerships to pursue SSP technology maturation and system developments should be considered and encouraged where appropriate.

Recommendation 5: International organizations, such as the International Academy of Astronautics, should play a constructive role in fostering and guiding future SSP/SPS studies, technology developments and policy deliberations.

CHAPTER 1**INTRODUCTION****1.1 Overview**

During the coming years, it will be crucial for the world to identify, research, develop, demonstrate, commercialize and deploy affordable and sustainable new energy sources. The need for new energy is driven by three factors: (1) growing global demand for energy to feed economic growth, (2) growing concerns regarding the long-term accumulation in Earth's atmosphere of fossil fuel-derived greenhouse gases, and (3) the prospect that during the coming decades global production of petroleum (and possibly other fossil fuels) will peak and begin to decline.⁴ A wide variety of aerospace technologies – including photovoltaic arrays, fuel cells, and wind turbines – have already been applied in conventional renewable energy systems. However, although already-existing “green” technologies can make a substantial contribution to the long-term energy challenge, these technologies are unlikely to provide the huge amounts of new and sustainable energy that will be needed in the coming decades.ⁱⁱ

As a result of the above factors, various new technologies now are being researched. One of the most promising and technically challenging of these is “space solar power” (SSP): the concept of collecting the virtually limitless energy of the sun available in space and delivering it safely and cost-effectively to communities on Earth.

1.2 The Global Energy/Environmental Context

There is now a tremendous need (and indeed for the remainder of this century) for the identification, development and deployment of new energy sources. This need is driven strictly by the demographics of Earth's rising population. However, the technological approaches that are employed to meet that economically driven demand for energy will directly determine the potential climate impact (i.e., greenhouse gas emissions) that result.

⁴ During Fall 2010 as this report was being completed, the IEA (International Energy Agency) reported that peak oil production had already been reached in 2006, and that the glut of natural gas supplies experienced in 2009-2010 will pass in the next several years, but slowly due to the global recession. (See <http://www.iea.org/>.)

Moreover, there is the increasing likelihood – the timing of which is still uncertain – that the production of key fossil fuels will peak during the coming decades, resulting in further risks to the global economy and quality of life.

Future Energy Demand

Despite setbacks such as the current recession, economic growth during the coming decades will demand dramatic increases in the supply of energy worldwide – including energy primary heating/cooling, transportation, and especially electrical power generation.ⁱⁱⁱ Table 1-1 (see below) provides a summary of characteristic current forecasts of future energy and environmental factors that provide the global energy context for the IAA’s consideration of the space solar power option.

Forecasts vary widely; however, a baseline would require two-times the level of energy consumption in 2010 by 2030-2040, and four-times that level by 2090-2100. Delivering that huge increase in energy will require massive development of new power plants, as well as new energy sources for transportation and other needs.

Future CO₂ Emissions and Climate Change

The Intergovernmental Panel on Climate Change (IPCC) has developed more than three-dozen analytical scenarios for CO₂ emissions that portray different patterns, ranging from (a) continuous increases in emissions (at varying rates) up to the year 2100, to (b) emissions that incrementally level off by 2100, to (c) reversals in CO₂ emissions trends in which they start to decline between 2050 and 2100. These alternatives depend greatly on detailed assumptions made in each case.⁵

At present there are no obvious solutions to meeting the global challenge that the risk of climate change represents during the remainder of this century: this is the reason why space solar power could be of great significance – if it can be developed successfully and power delivered from solar power satellites at an affordable (i.e., market competitive) price.

⁵ As of 2010, there continued to be significant controversy and debate regarding the reality of anthropogenic climate change, and concerning the uncertainty over the degree and the rate of climate changes that might occur due to growing CO₂ concentrations that have been measured over several decades. The approach taken by the IAA has been to consider these and other factors in terms of high-level global Scenarios that reflect alternative future outcomes that would materially affect the future energy marketplace; these are described in detail in Chapter 6 on Markets and Economics.

Table 1-1 Forecasts of Future Energy/Environment Factors⁶

		2010	2030-40	2060-70	2090-2100
Global Population	High ^{iv}	~ 6.9 billion	~ 9 billion	~ 11.5+ billion	~ 12.5+ billion
	Medium	~ 6.9 billion	~ 8.5 billion	~ 9+ billion	~ 8.5+ billion
	Low	~ 6.9 billion	~ 7.5 billion	~ 7+ billion	~ 5.5+ billion
Projected Annual Energy Consumption ^{7,v}		~ 120,000 Billion kWh	~220,000 Billion kWh	~ 400,000 Billion kWh	~ 480,000 Billion kWh
Renewable Energy	Percentage Share: High Case ^{8,vi}	~10%	~10%	~10%	~10%
	Percentage Share: Low Case ^{vii}	~10%	~50%	~70%	~90%
CO ₂ Emissions	IPCC Projected: High Case ^{9,viii}	~31 bn mT/year	~55 bn mT/year	~100 bn mT/year	~125 bn mT/year
	IPCC Projected: Low Case	~31 bn mT/year	~28 bn mT/year	~22 bn mT/year	~15 bn mT/year

Another Factor: Peak Fossil Fuel Production

Complicating the challenge of planning future energy sources and investments appropriately is the difficulty of anticipating when production peaks for various fossil fuels may occur. In 1956, an American geophysicist, M. King Hubbert, proposed that fossil fuel production in a given geographical region over time would follow a roughly bell-shaped curve that was a derivative of the logistic curve.^{ix} Figure 1-1 presents a version of the

⁶ Sources include the International Energy Agency (IEA) 2010 Forecast, the U.S. Department of Energy, Energy Information Agency Report of 2011, and others; these are annotated in Table 1-1.

⁷ The energy consumption projections shown are rough estimates only; they were developed for use by the IAA; they reflect a range of estimates from various organizations, and considerable uncertainties – including various projections of “high, medium and low” economic growth scenarios, variations in the economic efficiency of the energy (i.e., kWh-hours per unit of Gross Domestic Product (GDP), etc.).

⁸ The projections of the percentage share of total energy that is the result of renewable energy technologies is highly uncertain, of course; however, it is directly related to the CO₂ projections presented.

⁹ The longer-term projections of CO₂ emissions should be regarded even more uncertain than the projections of global energy consumption on which they depend. The available projects vary dramatically based on different assumptions about the economic efficiency of the energy (see previous footnote), the mix of energy sources, etc. The values shown for CO₂ emissions are approximations of the highest and the lowest projections presented in relevant IPCC studies.

original (1956) Hubbert Curve projected when peak oil production might occur.

The now well-known “Hubbert Curve” first illuminated the fact that petroleum is a finite resource, and that production in any given locality, and in fact for the world as a whole must peak at some point. In addition, other fossil fuels (including coal and natural gas) must also have natural production peaks. The question of the timing of when such peak production may occur is, not surprisingly, extremely controversial.

The scenario-based analysis used in this study involved a range of alternative possible production peaks for different fossil fuels; generally speaking earlier for petroleum, and later for natural gas and for coal. (Even in the case of the latter fuel there is great uncertainty as to when peak production may be reached, with one 2010 paper predicting peak coal production from existing mines might come as early as 2011-2012.³)

Figure 1-1 Initial / Generic Hubbert Curve: Prediction of Peak Oil

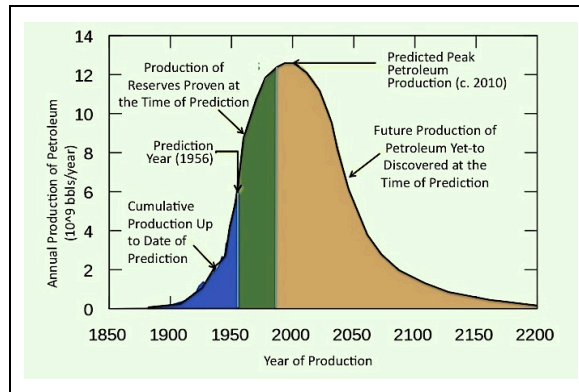

Credit: Artemis Innovation Management Solutions LLC (2010), after similar figure: http://en.wikipedia.org/wiki/Hubbert_peak_theory

Assessment of the Global Challenge

There are three critical observations to be drawn from this global energy and environmental context for the IAA study.

- First, it will be impossible for the projected population of Earth to realize a high quality of life without huge increases in total energy production / consumption during the remainder of this century.

- Second, the annual energy needed to assure economic opportunity for an increasing fraction of Earth's population (which will most likely continue to grow) will not be provided without massive deployment of new power generation capacity and other forms of energy utilization (e.g., transportation, primary heat / cooling, etc.).
- And, finally, the expected environmental impact of these increases in energy consumption will depend directly on dramatic advances in the technologies used to deliver that energy.¹⁰

In the absence of other factors (e.g., peaking of fossil fuel production, discussed below), it is evident that radical changes in the energy mix will be needed – not just by the end of the century, but within the next two decades: to realize the low-end of CO₂ emissions goals, the total amount of energy delivered by renewable sources must increase from roughly 12,000 Billion kW-hours per year in 2010, to more than 110,000 Billion kW-hours per year in 2030-2040, and to more than 430,000 Billion kW-hours per year by 2100.

Summary Observations

It is clear that solar power delivered from space could play a tremendously important role in meeting the global need for energy during the 21st century. There are four principal drivers for this conclusion. First, there is the likely (but not certain) increase in global populations. Second, there is the projected dramatic increase in the worldwide *per capita* demand for energy to enable economic development.

In addition, there is an urgent and continuing need to develop huge new renewable energy sources to resolve the challenge of greenhouse gas emissions from fossil fuels, and the increasingly certain risk of global climate change. And, finally there is the growing uncertainty in global supplies of existing fossil fuels; the issue of “peaking”, which if it occurs earlier rather than later and affects multiple fossil fuels could lead to drastic increases in energy prices (thereby strangling economic development).

This assessment of space solar power has formally incorporated these considerations through the use of a family of strategic scenarios which

¹⁰ Table 1-1 presents annual CO₂ emissions forecasts; the key parameter for global climate change is the total atmospheric concentration of greenhouse gasses (GHG), which is believed by the vast majority of scientists to drive global climate change.

attempt to reflect all four of the factors noted above, but focusing on the likely impact on energy prices that might result from (a) increasing demand; (b) GHG policies; and/or, (c) fossil fuel peaking. (See Chapter 6 for these Scenarios; and see Chapter 7 for the results of an assessment of examined SPS system concepts in the context of these alternative futures.)

1.3 Brief History of the Solar Power Satellite Concept

The concept of the “solar power satellite” (SPS) was invented first by Dr. Peter Glaser in the late 1960s. Figure 1-2 depicts the conceptual illustration of an SPS presented in Dr. Glaser’s original patent on the concept, granted on 25 December 1973.^{xi}

The SPS concept can be regarded as quite elegant: a large platform, positioned in space in a high Earth orbit continuously collects and converts solar energy into electricity. This power is then used to drive a wireless power transmission (WPT) system that transmits the solar energy to receivers on Earth. Because of its immunity to nighttime, to weather or to the changing seasons, the SPS concept has the potential to achieve much greater energy-efficiency than ground based solar power systems.

Since its invention, there have been numerous studies and technology projects conducted by various government agencies, companies and universities that have been focused on the goal of the Solar Power Satellite.

Figure 1-2 Illustration of the SPS Concept from the 1973 Patent

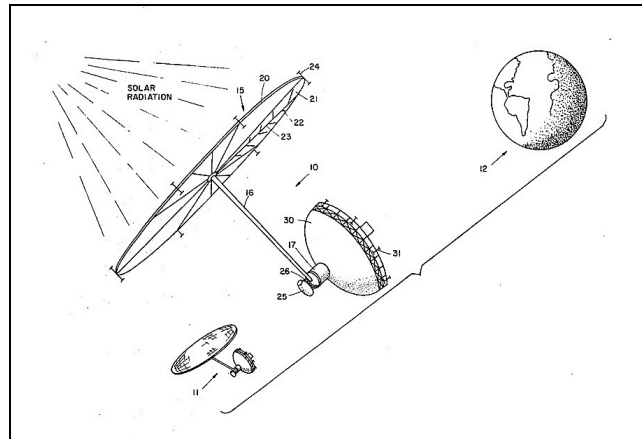

Credit: US Patent and Trademark Office; Patent No. 5019768

The first intense effort involved a series of studies conducted during the late 1970s in the United States (US) by the Energy Research and Development Agency (ERDA) – the predecessor of the Department of Energy – working with the National Aeronautics and Space Administration (NASA). Figure 1-3 presents at a high-level one of the principal systems concepts produced by this 1970s effort.

Figure 1-3 SPS 1979 Reference System Concept

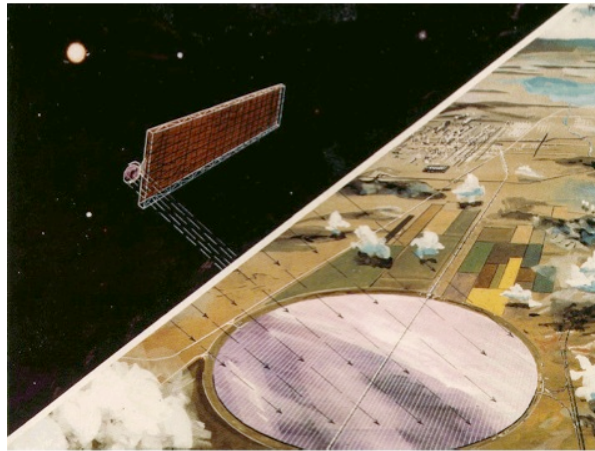

Credit: NASA / DOE Artwork

Unfortunately, in the 1980 timeframe, government sponsored SPS activities in the US were terminated following unfavorable reviews of the near-term feasibility of the concept by the US Congress Office of Technology Assessment (OTA) and the National Research Council (NRC). The 1980s and early 1990s saw an increasing number of international studies and small-scale demonstration projects, however (particularly in Japan, but also in Europe and Canada). These efforts resulted in a number of important technical advances, discussed later in this report. Then, during the 1990s and under the auspices of a recently created Advanced Concepts Office in Washington, DC, NASA conducted its first systems studies of the concept of SPS since the cancellation of efforts around 1980, leading to the “Fresh Look” study, and a subsequent series of exploratory research and technology efforts.^{xii, xiii}

By 2000, it was generally agreed that SPS were technically feasible. Moreover, although the necessary capabilities did not exist to assure the

economic viability of SPS, still the research and development (R&D) path to developing these satellites was judged to be of great potential value to future space endeavors. (This was the conclusion of an independent peer review conducted by the US National Academy of Sciences (NAS) National Research Council (NRC), published in 2000.^{xiv})

International interest in space solar power increased dramatically during the past decade—driven by the general concerns mentioned above and enabled by a wide range of impressive advances in key component and subsystem technologies.¹¹ This interest has been expressed through a variety of research and development (R&D) efforts, including studies and technology development in the U.S. (by both NASA during 1995-2003, and the National Science Foundation (NSF) during 2001-2003), ongoing R&D in Japan (e.g., by the Japanese Aerospace Exploration Agency (JAXA) and the Unmanned Space Experiments Free-flyer Institute (USEF)), recent and ongoing studies in Europe (e.g., the European Space Agency: ESA), more recent studies in the U.S.—for the first time under the leadership of the Department of Defense (DOD)—as well as interest in other space-faring countries of importance, such as India and China.

1.4 The International Academy of Astronautics Study

Despite increasing interest in new energy sources and various relevant R&D activities and studies by individual countries, questions remain regarding the economic viability of space solar power in the foreseeable future. Moreover, there has never been an integrated international assessment of the technological, market and legal conditions under which solar power satellites might become economically viable.

As a result, the International Academy of Astronautics (IAA) conducted the first international study of the concept of solar energy from space.¹² This assessment was conducted under the auspices of IAA Commission 3 (Space Technology & System Development) and involves participants from the Academy, a wide variety of other organizations, and

¹¹ The references that document this increase/activity in SPS interest are too numerous to list conveniently; see reports at the annual International Astronautical Federation (IAF) Power Committee Symposium, during 1995-2010, reports at AIAA (American Institute of Aeronautics and Astronautics) conferences, US National Space Society (NSS) conferences, and various stand-alone conference and events (such as SPS 2009, held in Toronto, Canada).

¹² See Appendix C for a copy of the originally submitted study group proposal (2007); also, see the annotation regarding the 2006 URSI SPS white paper on page 7.

diverse countries. The overall goals of the study were to determine what role solar energy from space might play in meeting the rapidly growing need for abundant and sustainable energy during the coming decades, to assess the technological readiness and risks associated with the space solar power concept, and (if appropriate) to frame a notional international roadmap that might lead to the realization of this visionary concept.

Because significant advances in space solar power systems could have a profound and positive impact on human and robotic space exploration capabilities as well as a range of space applications, the study identified such opportunities and evaluated the potential for synergies (if any) between these benefits for space missions and space solar power for terrestrial markets. Finally, the potential role that extraterrestrial resources might play in space development – including solar power satellites – is a topic that merits consideration.

The IAA study was initiated in Spring 2008 and concluded in Fall 2010 with the completion of this report.

Study Goals and Objectives

Study Goals. The overall goals of this study were to determine what role solar energy from space might play in meeting the rapidly growing need for abundant and sustainable energy during the coming decades, to assess the technological readiness and risks associated with the SSPS concept, and (if appropriate) to frame a notional international roadmap that might lead the realization of this visionary concept.

Because significant advances in space solar power systems could have a profound and positive impact on human and robotic space exploration capabilities as well as a range of space applications, the study also sought to identify such opportunities and evaluate the potential for synergies (if any) between these benefits for space missions and SSPS for terrestrial markets. Finally, there have long been discussions of the potential role that extraterrestrial resources might play in SSPS architectures; the study also attempted to identify these opportunities and assess potential connections between international lunar exploration programs now being undertaken and SSPS.

Study Objectives¹³. The following were the study objectives:

- Identification of relevant markets and applications for new energy sources—including both ultimate applications in terrestrial markets, as well as interim applications in space programs. [SG1]
- Identification and evaluation of the technical options that may exist for solar energy from space to contribute to meeting global energy needs. [SG2]
- Identification and evaluation of the technical options that may exist for space solar power to contribute to ambitious government and commercial space mission concepts and markets. [SG3]
- Identification and evaluation of options for the utilization of extraterrestrial resources, in particular lunar resources in future space solar power systems. [SG4]
- Preliminary determination of appropriate SSPS architecture level figures-of-merit, and values of these that must be achieved in order for space solar power to become economically viable for a range of terrestrial market opportunities and space applications. [SG5]
- Preliminary identification of other issues and policy questions that would require resolution for SSP/SPS to become a reality (e.g., spectrum allocation). [SG6]
- Assessment of the technical feasibility, technological maturity and degree of difficulty in the above space solar power options. [SG7]
- Formulation of a strategic approach to realizing the potential of energy from space—and one or more technical / programmatic roadmaps implementing this strategy. [SG8]
- Development of a summary report, documenting the results of the study and articulating the prospects for Energy from Space to make a substantial contribution to satisfying future global needs. [SG9]

Study Approach

Study Methodology. The study was organized within a functional work breakdown structure, emphasizing relevant systems and technologies, but including other factors as appropriate (e.g., market assessments), and was

¹³ The individual study group objectives are designated as “SG1”, “SG2”, etc.; these designations are highlighted in the individual Chapters, and the Executive Summary to allow traceability from the objectives to the detailed results of the study and vice versa.

implemented primarily through a web-based approach with periodic working meetings at IAA meetings and major conferences where appropriate (e.g., at the IAC International Program Committee (IPC) meeting in Spring 2008, the International Astronautical Congress (IAC) in Fall 2008, etc). Also, several dedicated working meetings were organized and one major workshop/conference.

In addition, sessions were organized at subsequent IACs in full cooperation with the International Astronautical Federation (IAF) Power Committee, with papers being invited that address key topics in support of the study objectives. The results of these efforts were documented in this formal final report, plus supporting information.

Study Results Integration. Throughout history, a principal challenge for any fundamentally new approach to energy is the tremendous change required in diverse systems; including social systems, transportation systems, diverse systems that use the new energy source; etc. This was certainly true in the transition from a largely wood-burning, gas-lit society to one that relied largely on coal-fired power plants and petroleum-based fuels. The same transformation will be necessary in the eventual emergence of space solar power – and the integration approach that was used for the IAA study reflects this complexity and the diversity of technical issues involved. Figure 1-4 presents an overview of this integration methodology.^{xv} The major stages in the integration process are summarized in the subsections that follow.

Framing the Study. The most important stage in finding a solution is the appropriate framing of the problem. The first stage in the study effort – framing the study – comprised four important activities: (1) the definition of an overall trade space of options (including architectural choices, systems concepts and technology alternatives); (2) the identification of key figures of merit (FOMs) for SPS (e.g., cost per kilowatt-hour, mass per kilowatt delivered to Earth, etc.); (3) formulation of a “Limits Analysis” for the study (described below); and (4) definition of specific SPS cases that were to be included in the IAA’s primary study efforts.

Assessing the Details. The second stage in the integration process is that of assessing the details of various aspects SPS – including challenges and opportunities, markets and technologies, policies and infrastructures. An important component of the IAA study was a 3-day International

Symposium on Solar Energy from Space, including a technical workshop (being organized by the International Academy of Astronautics) and an international policy forum. A number of other interested organizations were also participants in the organization and/or sponsorship of the meeting, including SPACE Canada (a non-profit organization dedicated to facilitating international dialog on SPS through education, research and commercialization), the Space Power Association (a.k.a., the Sunsat Energy Council), the FATE Consortium, and others. The meeting was held in Toronto, Canada on 8-10 September 2009 at the Ontario Science Centre.

Figure 1-4. IAA SSP Study – Integration Approach

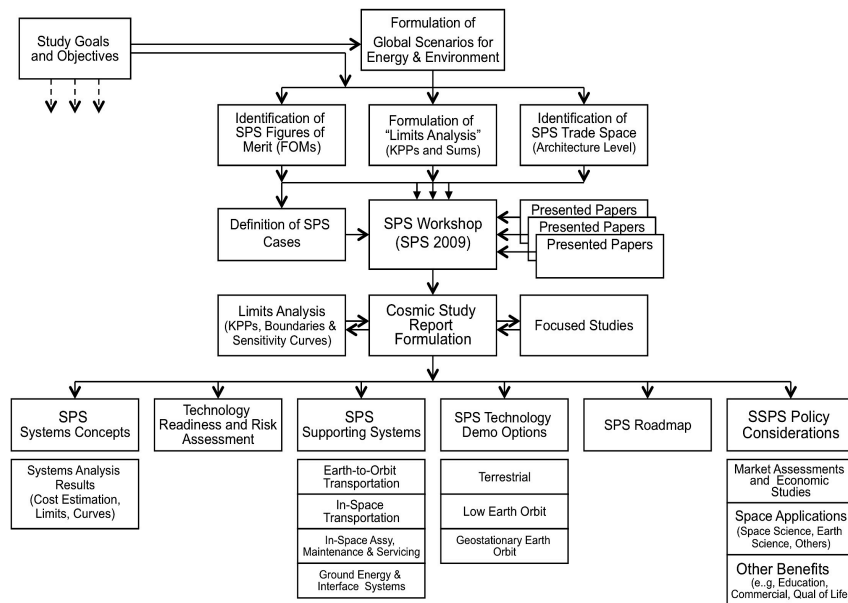

The workshop comprised a series of plenary sessions that covered general issues and detailed working sessions (e.g., the Scenarios, SPS Cases, etc.) that addressed more specific topics (such as Earth-to-Orbit transportation, in-space assembly, etc.).

Formulating the Results & Report. Of course, following the completion of the various working aspects of the study effort, the last stage was the formulation of results and the development of the final report for the effort. The report, which was developed by a subset of the study team, based on the workshop results and other references, comprises a number of

important topics, ranging from specific SPS systems concepts, to an assessment of technology readiness and risks, to various SPS policy considerations. (See Figure 1-4.)

The following section describes the organization of this final report.

1.5 Organization of this Report

This report is organized into the following chapters.

Executive Summary. The executive summary provides a high-level synopsis of the overall study – including methodology, results and recommendations.

Chapter 1, Introduction. This chapter presents some background on the concept of the SSP, an overview of the IAA study and the approach to the conduct of the study, and a high-level description of the documents organization.

Chapter 2, Solar Power Satellite Systems Concepts. This chapter describes at a high level the highly promising SPS platform concepts that are treated by the IAA study. It provides a framework for the remainder of the report.

Chapter 3, SPS Supporting Systems. This chapter presents selected important systems that would support the development, operations and maintenance of SPS platforms including both ETO and affordable in-space transportation.

Chapter 4, Technology Readiness and Risk Assessment. This chapter provides a summary assessment of the key technologies required for primary candidate SPS platform types and the associated supporting systems. It provides the basis for the technology roadmap (Chapter 8).

Chapter 5, SSPS Policy and Benefits Considerations. The fifth chapter discusses various important policy considerations for SPS, such as spectrum allocation. The chapter also summarizes potential benefits of SPS development, such as novel space system applications.

Chapter 6, SPS Market Assessment and Economics. This chapter articulates a set of strategic scenarios for the future that frame potential SSP/SPS markets and economics. The chapter also reviews past studies of

SSP economics and defines the framework for establishing figures of merit (FOMs).

Chapter 7, Preliminary Systems Analysis Results. The seventh chapter presents the methodology for, and results of preliminary systems analyses of space solar power and supporting systems options. It presents cost sensitivity analysis results in terms of the key SPS FOMs (identified in Chapter 6).

Chapter 8, International SPS Strategic Roadmap. Based on the preceding chapters, this Chapter 7 synthesizes a high-level roadmap for SSP/SPS, detailing a prospective path forward for the international space and energy community.

Chapter 9, Summary: Conclusions and Recommendations. The final chapter summarizes the results of the study and presents its findings. The chapter concludes with specific recommendations for future studies and R&D.

In addition, there are several appendices, including a Glossary of Acronyms and a Summary of References.

The next Chapter begins the detailed discussion of the study's results with a review of SPS system concepts – focusing on the three types of SPS that were chosen by the IAA for emphasis.

CHAPTER 2**SOLAR POWER SATELLITE SYSTEMS CONCEPTS**

The starting point for the Academy’s technical evaluation of space solar power was the identification and characterization of various SPS system concepts, along with several significant supporting systems and infrastructure. There are three principal systems approaches to space solar power that might be pursued for various mission and market applications during the coming 2-3 decades. These are the following: (1) Microwave WPT / Classic Power Management Architecture; (2) Laser WPT / Tower or Free-Flying Power Management Architecture; and (3) Microwave WPT / Sandwich Power Management Architecture. Each of these options has been examined in the context of a high-level SPS Reference Mission, described below.

2.1 Space Solar Power Reference Mission(s)

In order to more clearly define the point-of-departure being used for this comparative assessment of SPS system architecture alternatives, a “Solar Power Satellite Reference Mission” has been defined for the first full-scale solar power satellite. In addition, two “Pathway Missions” have also been defined – i.e., earlier flight missions that would serve as stepping-stones in a roadmap toward the SSP Reference Mission. These Pathway Missions are defined as Pathway Mission 1 (an early, sub-scale SSP technology system demonstration), and Pathway Mission 2 (an SPS Pilot Plant systems demonstration). See Figure 2-1 for a summary of the SPS Reference Mission and the Pathway Missions.

The SPS Reference Mission has been defined in terms of three *Primary Goals* without regard to specific technical implementation considerations; these are: (a) the SSP System Purpose(s); (b) the total Power Delivered from the WPT receiver on Earth; and, (c) the Specific Price to be paid by for energy delivered from the SPS to a terrestrial market. In addition, a set of *Secondary Characteristics* have been identified that may be generally considered as necessary to achieve the Specific Price goal.

Figure 2-1 Space Solar Power Reference Mission(s)

Targeted SPS Engineering & Economic GOALS & Characteristics		SPACE SOLAR POWER REFERENCE MISSION(S)		
		SPS Reference Mission Initial Full-Scale Solar Power Satellite	Pathway Mission 2 Solar Power Satellite Pilot Plant	Pathway Mission 1 Sub-Scale SSP Technology Demonstration
PRIMARY GOALS	SSP System "Purpose(s)"	Operational SPS Delivering "Baseload" Power to Earth Market	SSP System Demo to TRL 7 Post-Demo SPS System Delivering "Niche" Power	SSP Technology Demonstration to TRL 5-6
	Power Delivered (from WPT Receiver)	> 1 GW	> 10 MW	> 10-100 kW
	Specific Price for SPS Energy	10¢ - 50¢ / kW-hr	\$1.00 - \$5.00 / kW-hr	N/A
SECONDARY CHARACTERISTICS	On-Board Power (to WPT Transmitter)	< 2-4 GW Power @ > 200-400 W/kg-SPS	< 20-80 MW @ 100-200 W/kg-SPS	< 100-400 kW
	Orbital Location	GEO	LEO or GEO	LEO
	SPS Hardware Systems	> 20-30 years Lifetime @ < \$500-\$1,500/kg	> 10-15 years Lifetime @ < \$2,000-\$4,000/kg	> 3-5 years Lifetime
	Earth-to-Orbit Transport (to LEO)	SPS-Specific Launcher @ < \$500-\$1,500/kg	Existing or New Launcher @ < \$1,000-\$3,000/kg	Existing ELV @ 1-3 launches
	In-Space Transport (LEO to GEO)	New Technology LEO-GEO @ < \$1,000-\$3,000/kg	New Technology LEO-GEO @ < \$2,000-\$6,000/kg	Existing Technology (LEO Maneuvering)
	In-Space Assembly / Operations	Fully Autonomous Ops @ < \$500-\$1,500/kg	New Technology Demo. @ < \$1,000-\$3,000/kg	Improved SOA (Potential EVA Assist)

The *Secondary Characteristics* are: (1) the total on-board SPS power delivered to the WPT transmitter; (2) the orbital location of the SPS platform; (3) the lifetime and power per unit mass of the SPS platform; (4) the cost per kilogram for ETO transport of SPS systems hardware; (5) the cost per kilogram for in-space transport of SPS systems hardware; and, (6) the cost per kilogram for in-space operations (including assembly) of SPS systems.

In summary, the SPS Reference Mission involves the deployment of the initial full-scale SPS that delivers not less than 1,000 MW to commercial markets on Earth at a price between \$0.10 and \$0.50 per kilowatt-hour (currency in dollars, US). The high-efficiency and low mass operational SPS platform (i.e., less than 2-4 GW power to the WPT transmitter, at greater than 200-400 watts per SPS kilogram) is to be deployed autonomously in GEO and operate for not less than 20-30 years. Principal infrastructure elements include advanced ETO and in-space transport (providing respectively launch at not more than \$500-\$1,500/kg, and LEO-GEO transport at not more than \$1,000-\$3,000/kg). In this context, it is

presumed that the economics of the energy market and further technological advances would determine the costs/prices for subsequent solar power satellites after the first SPS.

The key rationale for both of the Pathway Missions is the demonstration of critical technologies and systems at a sufficient scale and level of manufacturing to allow the next step(s) to be achieved with confidence. An additional rationale for Pathway Mission 2 (the SPS Pilot Plant) is the deployment of an operational SPS capability that can deliver power into premium niche markets on Earth. The two Pathway Missions have also been defined in terms of the same *Primary Goals*, and *Secondary Characteristics* (see Figure 2-1).

In the case of the ETO launch infrastructure, it is projected that an existing launcher may be capable of implementing either of the Pathway Missions (depending on the launch price), but that a new launcher will be needed for the SPS Reference Mission. However, new in-space transportation will be needed with Pathway Mission 2 (if it is deployed to GEO). Similarly, although Pathway Mission 1 may be implemented with modest improvements to the state-of-the-art (SOA) in space operations, later missions will require advanced capabilities (e.g., highly autonomous robotic space assembly, maintenance and servicing) to realize economic objectives.

The above SSP Reference Mission(s) provides a working framework for the examination of alternate SPS systems concepts. However, clearly they are preliminary in character, and may require substantial revision and much more detailed elaboration following future end-to-end systems analysis and study.

2.2 Generic Solar Power Satellite Functional Architecture

In order to evaluate and compare the various SPS approaches (identified above), it was necessary to determine if there are common functional elements that characterize most or all of these. Fortunately, this was indeed the case. Figure 2-2 presents a high-level / generic solar power satellite (SPS) functional architecture that was used to characterize the several types of promising SPS system concepts

The major categories of operations / systems within this generic SPS functional architecture are:

- Primary SPS Platform Systems
- Secondary SPS Platform Systems
- Ground Systems
- Supporting Systems / Infrastructure

Figure 2-2 Generic SPS Functional Architecture

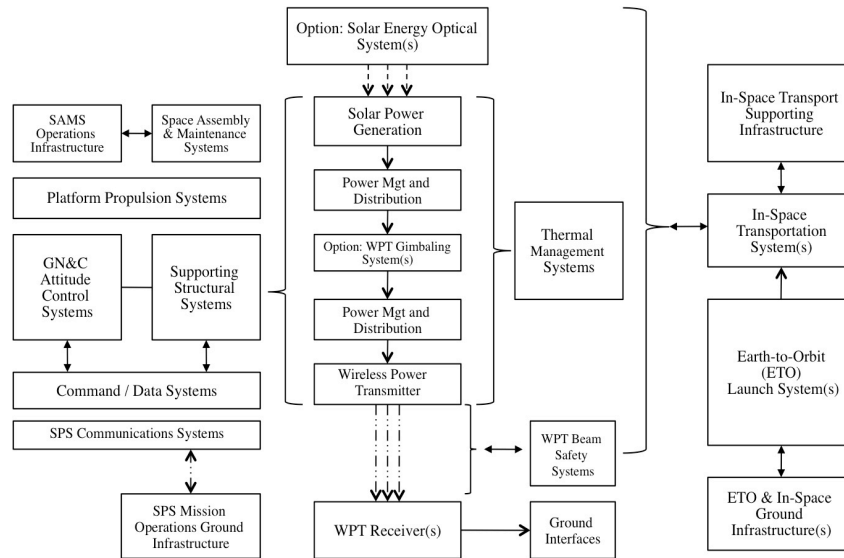

Appendix E provides a detailed evaluation of these major functional areas, for each of the three Types of SPS examined by the IAA study. Including the organization of each of the major elements of the generic SPS functional architecture into each of these categories. (Note: most of the elements listed in Appendix E are common to all types of SPS that are of interest. However, a number of them are identified as “options”. In these cases, the functional system element is needed for one or more of the SPS types, but is not needed in all cases.)

The section that follows provides summary descriptions of the three SPS Types examined by the IAA study, as well as the high-level evaluation results for each of these.

2.3 Summary Evaluation of SPS Types Examined

The following are the summary results of the evaluation of each of the three Types of SPS examined.

Updated 1979 SPS Reference (SPS Type I)

Concept Overview. This approach is epitomized by the architecture used in the 1979 SPS Reference System Concept. It involves one or more large, sun-pointed solar collection systems and an Earth-pointed WPT system that involves the use of microwave radio frequency (RF) for power transmission. The architecture is that of an extremely large 3-axis stabilized platform. Connecting sun-pointing and Earth-pointing elements is a large-scale power management and distribution system (either high-voltage or superconducting), including a “live” rotating coupler. This architecture includes large-scale ground based rectifying antennas (“rectennas”) as receivers for the transmitted power, as well as appropriate safety assurance systems. The receivers might be positioned within 100 km or less of markets to be served, depending locality details. This class of SPS concepts is identified as “Type I” in this report. Figure 2-3 illustrates this type of SPS.¹⁴ (Additional architectural details are provided in the Appendices.)

Figure 2-3 Type I “Microwave Classic” SPS

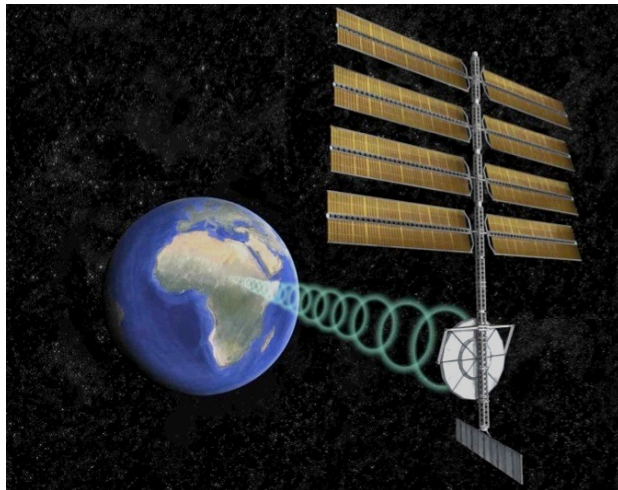

Credit: Artwork provided courtesy SpaceWorks Engineering, Inc. / Spaceworks Commercial

¹⁴ Note: the three SPS figures presented here reflect conceptualizations, rather than the results of any particular detailed engineering study.

High-Level Assessment Results. The updated 1979 SPS Reference System is the most traditional of the architectures examined in the IAA study. It employs – albeit at an extremely huge scale – a traditional three-axis stabilized platform architecture of the type that has been used in spacecraft since the 1960s. An updated version of this microwave WPT concept would take advantage of various advances in technology, including improvements in robotics, materials, electronics, and others. There appear, however to still be some very significant systems-technology challenges involved in the 1979 SPS Reference Concept approach – even including numerous advances in various component technologies.

The most significant challenges involve three issues. The first issue is the need for an extremely large, high-voltage power management and distribution system on the platform (including across the gimbaling system). Another issue is the requirement for substantial up-front infrastructure both in –space and for ETO transport. Finally, there is the market support issue that the mechanically pointed transmitter array is far less capable of meeting “energy on demand” opportunities that other SPS concept types.

SPS Electric Laser Concepts (SPS Type II)

Concept Overview. Electric laser SPS concepts can be of either of two basic types: (1) electric-laser based or (2) solar-pumped laser. At present, the former – electric lasers – appear to be the most feasible in the foreseeable future. Within the area of laser SPS, there are several alternative systems approaches, involving either integrated platforms comprising multiple individual laser systems or constellations of free-flying laser platforms. The concept chosen for characterization by the IAA study was that of an integrated platform, comprising multiple largely independent solar power generation and laser power transmission elements. The receiver is assumed to be bandgap tailored PV arrays; these might be placed within 100 km of markets to be served, but must comply with eye-safety and related constraints. Figure 2-4 illustrates this concept. (Additional architectural details are provided in the Appendices.)

High-Level Assessment Results. The second SPS Type considered by the study is enabled by a completely different approach to wireless power transmission involving laser power beam generation at the near visible part of the spectrum such as near Infrared (IR) wavelengths. This architecture option includes large-scale ground based tailored photovoltaic systems as

receivers for the laser power, as well as appropriate operational safety assurance systems. This class of SPS concepts is identified as “Type II” in this report.

Figure 2-4 Type II “Modular Electric Laser” SPS

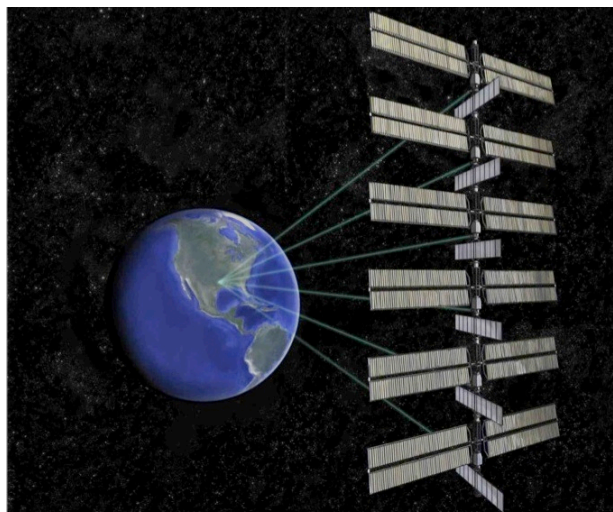

Credit: Artwork provided courtesy SpaceWorks Engineering, Inc. / Spaceworks Commercial

Modular electric laser SPS concepts appear to be technically feasible using available technologies. However, using technologies that are currently available, electric-laser SPS concepts have a significant challenge to compete in terms of end-to-end efficiency with microwave based concepts at power levels greater than approximately 100 MW. Significant improvements in various critical technologies (e.g., the efficiency of laser power generation) are needed to achieve acceptable levels of WPT end-to-end efficiency. In the absence of these advances, the total waste heat that must be rejected from the individual SPS platform modules could be unacceptably high; this is a major technology development challenge for the Type II SPS concept.

SPS Sandwich and Related Concepts (SPS Type III) Assessment Results

Concept Overview. The Type III SPS option examined by the IAA study is the SPS Sandwich and related concepts, implemented with a highly modular architecture. This approach involves a light-redirection based approach to energy distribution on the SPS platform (as opposed to voltage based PMAD). It also depends upon the successful local integration of

solar power generation, PMAD, and WPT systems in extremely large numbers of individual modular space systems. This architecture option includes large-scale ground based rectenna systems as receivers for the microwave power, as well as appropriate operational safety assurance systems. The receivers might be positioned within 100 km or less of markets to be served, depending on locality details. Figure 2-5 illustrates this type of SPS. (Additional architectural details are provided in the Appendices.)

Figure 2-5 Type III “Modular Sandwich Microwave” SPS

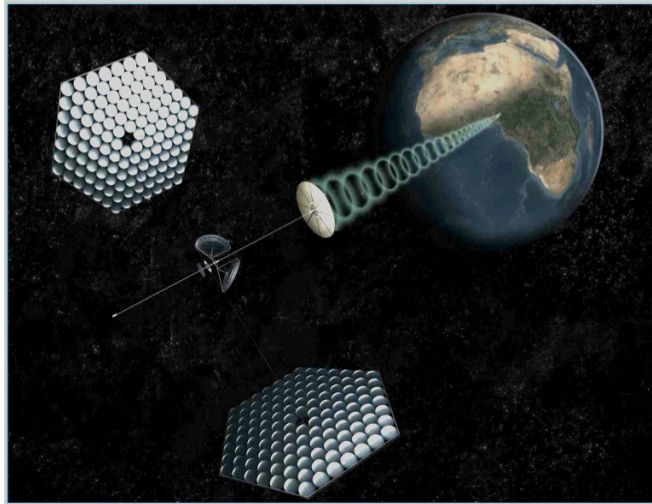

Credit: Artwork provided courtesy SpaceWorks Engineering, Inc. / Spaceworks Commercial

High-Level Assessment Results. This third approach involves light-redirection based approach to energy distribution on the SPS (as opposed to voltage based PMAD), and depends upon the successful local integration of solar power generation, PMAD, and WPT systems in large numbers of individual modular space systems. This architecture option includes large-scale ground based rectenna systems as receivers for the microwave power, as well as appropriate operational safety assurance systems. This class of SPS concepts is identified as “Type III” in this report.

The modular Sandwich-type microwave SPS concepts appear to be technically feasible using available technologies. Available microwave devices have good efficiencies (e.g., 50%-70%), however improvements are needed to achieve acceptable levels of WPT end-to-end efficiency and cost

of power. Although design alternatives exist, the local waste heat that must be rejected from the individual SPS sandwich modules at the center of the transmitter (in the case of a Gaussian Distribution) could be unacceptably high; this is a major technology development challenge for the Type III SPS concept.

The section that follows provides summary information on several other approaches to the goal of space solar power.

2.4 Other Approaches to Space Solar Power

There are a diverse number of other concepts for space solar power, including alternatives types of SPS platforms and alternative deployment locations. Many of these options were identified in the 1995-1997 NASA SSP “Fresh Look Study”, the purpose of which was to determine whether new technologies (emerging since the 1970s) might make possible new, more affordable SPS systems concepts.^{xvi,xvii} Several of the more well-known and/or interesting alternative space solar power concepts include:

- The SunTower SPS (LEO or GEO),
- The Integrated Symmetrical Concentrator (ISC) SPS (GEO)
- Lunar surface-based Lunar Solar Power (LSP),
- GEO-based Solar-Pumped Laser SPS,
- Earth-Sun L-2 Libration Point SPS, and
- Earth Orbiting Reflectors (Sunlight Reflected to Earth).

Each of these is summarized in the paragraphs that follow.

SunTower SPS

The SunTower SPS concept is a highly-modular, gravity-gradient stabilized platform concept, in which power generation is divided in a large number of identical units for solar power generation, each of which feed power through a central backbone power management and distribution (PMAD) system to an integrated, electrically-steered RF transmitter at the nadir / Earth-pointing end of the platform. Mr. John C. Mankins of NASA created the SunTower during the US “Fresh Look Study” (1995-1997).^{xviii}

Although it could be located in GEO, the baseline orbit for the SunTower SPS was low Earth orbit. See Figure 2-6 for an illustration of the concept.

Figure 2-6 SunTower Modular SPS Concept Based in LEO

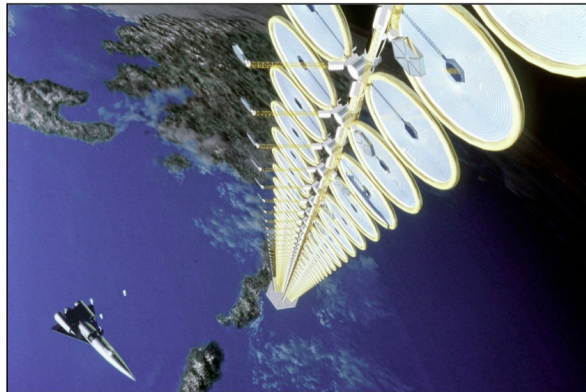

Credit: NASA Artwork, by P. Rawlings / SAIC c. 1996

In one case, a large number of comparatively small scale SunTower SPS would have been placed in a LEO sun-synchronous orbit to provide power during the hours around dawn and dusk at various locations on Earth (complementing ground based solar power systems). The GEO version of the SunTower inspired the ESA “Sail Tower” SPS concept, in which the individual solar power modules (which were to be concentrator solar power (CSP) modules in the SunTower) were replaced with thin-film PV modules in the Sail Tower case. This approach is shown in Figure 2-7.

Figure 2-7 European SailTower SPS Concept Based in GEO

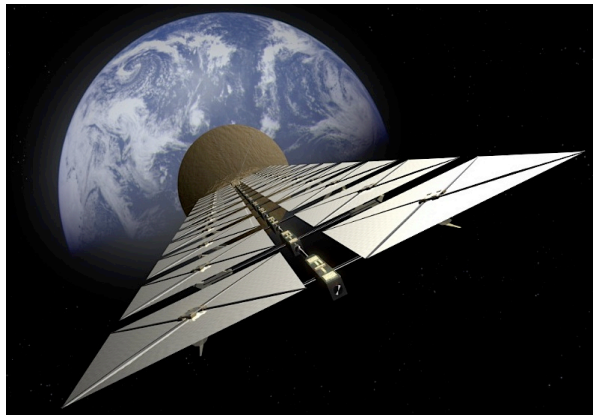

Credit: ESA Artwork, provided by L. Summerer

The technically feasible SunTower concept had the advantage that it eliminated the requirement for an exceptionally large mechanical / power conveying gimbaling system (which is needed for the 1979 Reference System type SPS). However, the SunTower failed to resolve the issue of the large PMAD system – particularly that required for the transfer of power across the backplane of the microwave transmitter.

Also, in order to avoid self-shadowing of the SPG elements, the SunTower entailed an extremely long (e.g., 10s of kilometers long) backbone. Another variation on this concept was the subsequent European “SailTower SPS” concept, which used thin film PV arrays in lieu of the concentrator PV systems that were assumed for the SunTower baseline design.

Integrated Symmetrical Concentrator SPS

The Integrated Symmetrical Concentrator (ISC) SPS concept is a hybrid concept, highly modular in some regards, but including centralized systems for key functions (including power generation and distribution, and thermal management systems). The ISC closely resembles the Modular Symmetrical Sandwich concept. Figure 2-8 presents a conceptual illustration of the ISC SPS concept. (Also shown in the figure is a LEO-GEO transport version of the modular SEPS Solar Clipper concept (discussed later in this report.)

The ISC concept incorporated large, symmetrically located thin-film concentrator systems to collect sunlight and direct it for conversion via multi-bandgap PV arrays into power; the solar power generation (SPG) in the ISC case being “body mounted” to the primary transmitter as a strategy to eliminate the critical single/dual point of failure from the “Microwave Classic Update” type concept – namely, the enormous, high power/high voltage yoke and gimbaling system required to connect the PV array and the microwave transmitter. John C. Mankins of NASA, and the SERT project team, led by Mr. Joseph T. Howell of the Marshall Space Flight Center (MSFC) created the Integrated Symmetrical Concentrator SPS concept during the “SSP Exploratory Research and Technology (SERT) Program at NASA (1998-2000).¹⁵

¹⁵ NASA MSFC’s Don Perkins played an important role in the formulation of the ISC.

A principal objective in the creation of the ISC concept was to explore an alternative / hybrid SPS system design that might combine the best features of the 1979 Reference System concept and the Sandwich SPS concept, while resolving the significant thermal management challenges of the latter approach. This was accomplished by separating the solar power generation system from the WPT transmitter (as shown in Figure 2-3).

A key advantage of the ISC approach, compared to the traditional SPS architecture was the elimination of the very large rotating gimbaling system (noted above). A principal disadvantage was that the concept still entailed important, power scale specific system elements (e.g., PMAD) that in turn required several generations of distinct systems development project – each of which would require 3-6 years to complete. This idea of planning for multiple generations of systems development at increasing power levels (e.g., 100 kW, followed by 1 MW, followed by 100 MW, etc.) represented a key underpinning of the SSP technology roadmaps presented in 2000 to a committee of the U.S. National Research Council (NRC) for review.^{xix}

Figure 2-8 Integrated Symmetrical Concentrator GEO SPS Concept

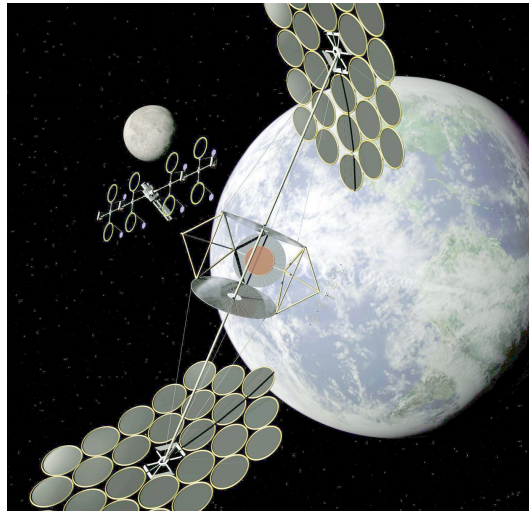

Credit: NASA Artwork, by P. Rawlings / SAIC c. 1998

For purposes of the present study, the ISC concept is not included as one of the three principal systems types for several reasons. First, if high SPS device efficiencies can be realized, then the Sandwich approach appears far more promising as a microwave SPS concept. Second, the ISC is a

hybrid approach – meaning that the principal technologies challenges of interest are documented within the three SPS concept types that are included. (In the event that thermal management challenges of the Sandwich SPS concept cannot be resolved, then the ISC approach represents a promising alternative – albeit a more expensive option.)

Lunar Solar Power

“Lunar Solar Power” (LSP) is the concept of locally manufacturing, deploying and delivering power from space solar power systems on the lunar surface. Dr. David Criswell of the University of Houston invented the LSP concept during the 1980s.^{xx} Figure 2-9 provides a high-level conceptual illustration of the concept. The principal advantage of the LSP concept is that it minimizes the operational mass launched from Earth per kW-hour delivered to terrestrial energy markets.

However, the LSP approach entails the greatest amount of upfront infrastructure investment of any SPS concept in that it requires initial installation of large-scale infrastructure on the Moon prior to the beginning of power system construction. (However, LSP dispenses with the need for exceptionally low cost ETO transport or large scale ISAAC platforms in LEO or GEO.)

Figure 2-9 Lunar Solar Power Concept

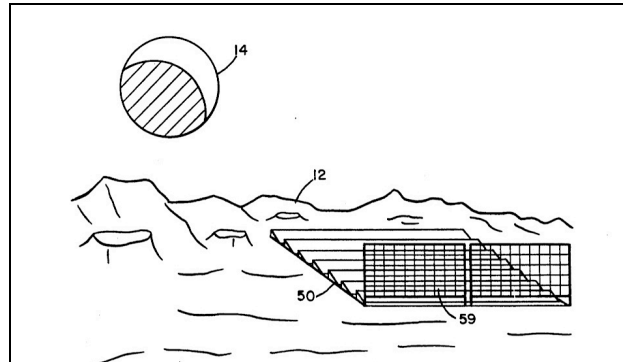

Credit: US Patent and Trademark Office; Patent No. 5019768

At the architecture level, a key issue for LSP is the increase in the distance: 384,000 km for the Moon, versus approximately 36,000 km for GEO. Because of this increase in distance, the diameter of an RF

transmitter must also increase by a factor of 10 – resulting in an increase of approximately 100-fold in the area in order to maintain the size of the receiver on Earth at about the same diameter (some 10 km) as the GEO case. For an active beam-steering transmitter, this means an increase of 100-times in the number of phased shifters / active electrical sub-elements.

In addition, to provide continuous power to a given location on Earth (a principal advantage of SPS), WPT transmissions would require the positioning of huge relay satellites in high Earth orbit, all of which would require physical pointing or large numbers of phase-shifting sub-elements – adding another layer of complexity to the concept.

GEO-based Solar-Pumped Laser SPS

Solar-pumped laser SPS concepts are based on the phenomena of direct stimulation of laser emissions by concentrated sunlight. This concept has the theoretical advantage of avoiding the efficiency losses that occur at the solar power generation, power management, and wireless power transmission system stages of other SPS concepts. Figure 2-10 provides an illustration of a JAXA concept for a solar-pumped laser type SPS.

Figure 2-10 Solar-Pumped Laser SPS Concept (by JAXA)

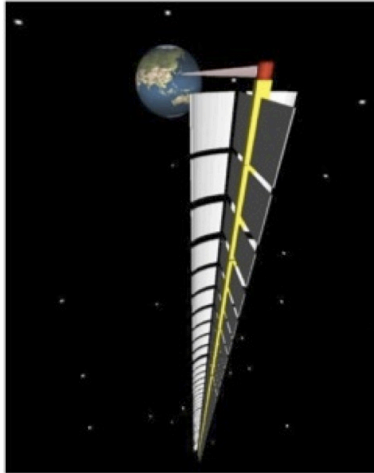

Credit: JAXA

This concept was developed several decades ago when the efficiencies that could be achieved by solid state, electrical laser systems were extremely low; the solar pumped laser option offered potentially much higher

efficiencies. This system concept requires both optical systems for the collection of incoming sunlight and its precision delivery to the laser, and the direction of the resulting laser light to the desired receiver on Earth.

Several critical technology challenges remain. First, it is unclear how the concept could achieve assured fail-safe operations (without the risk of weaponization). Second, solid state lasers have now achieved good efficiencies, with the promise of much higher performance within the next several decades.

Earth-Sun L-2 Libration Point SPS

From the Sun-Earth L-2 Libration point, an SPS can be continuously illuminated from the same side of the spacecraft that transmits power to Earth. This allows the backside of the satellite – facing cold space – to be used as a more efficient radiator of waste heat into space.

Figure 2-11 provides a high-level illustration of the Sun-Earth L2 Lagrange Point SPS concept. (Dr. Geoffrey Landis of NASA Glenn Research Center (GRC) originally conceived of this approach.)

Figure 2-11 Sun-Earth L2 Lagrange Point SPS Concept

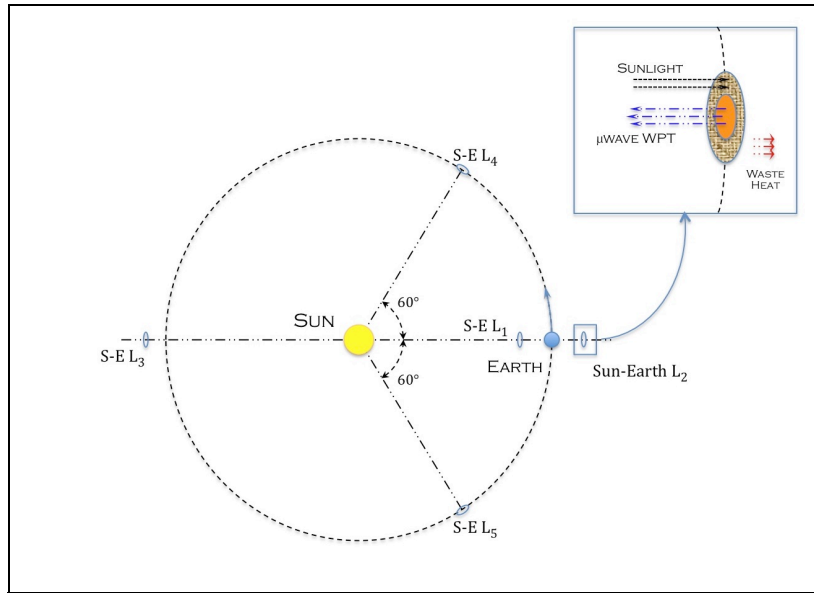

Credit: Artemis Innovation Management Solutions LLC

This principal difficulty with this concept is that the distance from Earth to the Sun-Earth Lagrange Point L2 is approximately 1.5 million kilometers – about 40 times more distant than GEO. As a result, for a given frequency, the same receiver size on Earth would require a transmitter with a diameter 40-times greater than an SPS in GEO (or, about 1,600-times greater in area, mass and cost). In addition, continuous delivery of power to terrestrial markets requires Earth-orbiting reflectors (as is the case for the LSP option).

Earth Orbiting Reflectors (Sunlight Reflected to Earth)

This option is not, properly speaking, a solar power satellite of same type as that invented by Dr. Peter Glaser in the 1960s. Rather, this is the idea of placing large, lightweight mirrors in Earth orbit that would directly reflect sunlight down to solar arrays positioned on Earth.^{xxi} This idea has an inherent appeal: what could be simpler than simply using a mirror to send power down from space? Figure 2-12 presents an illustration of this concept. (This concept, known as “Solares”, was discussed as an option during the late 1970s.)

Figure 2-12 Solar Reflector in Earth Orbit Concept

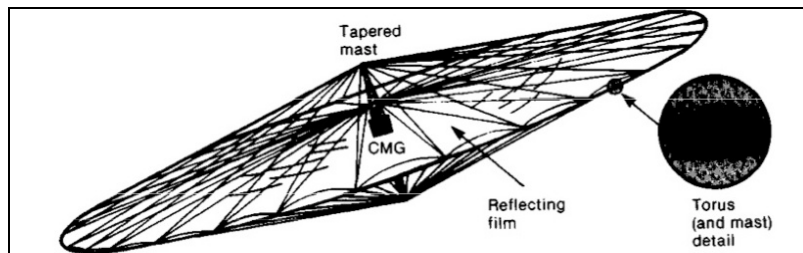

Credit: US Congressional Office of Technology Assessment (c. 1980)

The concept of the Earth orbiting reflector has the following advantages: (1) no requirement for energy conversion systems on the spacecraft (i.e., no PV arrays); (2) no need for electronic wireless power transmission systems (i.e., no microwave phased array or laser systems); and, (3) no requirement for either power management and distribution (PMAD) or thermal management systems (TMS) on the spacecraft.

However, there are a number of significant technical challenges that make this concept far less promising than it might appear.

Firstly, reflected sunlight is entirely subject to the effects of weather: overcast, haze and atmospheric refraction will all affect the reflected light. Although the sunlight may be delivered continuously from a mirror in space, that light will only reach a receiver on the surface during a fraction of that time – and only a portion of the initial energy will arrive. (Recall that in sunlight in space at Earth has an energy density of roughly $1,350 \text{ W/m}^2$, whereas sunlight at midday near the equator on Earth has an energy density of roughly $1,000 \text{ W/m}^2$.)

Moreover, even though it is roughly 150,000,000 kilometers distant, the sun is a finite object in the sky and the rays of sunlight coming from it are not parallel. As a result, the light that makes up the image of the sun reflected from a mirror spreads out with distance from the mirror. In the case of a 1meter diameter mirror positioned in geostationary Earth orbit (GEO; an altitude of roughly 35,800 km), the size of the reflected spot of light at a location on Earth would be several hundred kilometers in diameter. In order to deliver solar energy at an intensity of roughly “1 sun” – i.e., $1,000 \text{ W/m}^2$ – at Earth, a mirror in GEO orbit would also need to be several hundred kilometers across.

Finally, because of the scale of the mirror required, the technology challenge involved in its construction would be immense. The solar reflecting mirror in orbit must be optically flat (to a fraction of a wavelength of light), over an area 100s of kilometers in diameter and 10’s of thousands of square kilometers in area. For comparison, the mirror surface of the James Webb Space Telescope (JWST), now in development is only 6.5 meters in diameter. In addition, the size of the ground receiver would be on the order of 100 km in diameter and would require dedicated utilization by conventional solar arrays across this area. Fundamentally new approaches to large space imaging systems will be required (i.e., the current technology readiness level for this concept is TRL 2 or less.

Results of the Assessment of “Other Approaches”

There are a wide variety of alternative SPS architectural approaches. Many of these involve special locations where the space solar power system might be placed (LEO, the surface of the Moon, a Libration Point, etc.). Others involve specific technologies for wireless power transmission (e.g., the solar pumped laser SPS). Six of the most interesting alternative approaches have been examined in the preceding section. Some of these

are relatively mature (e.g., the ISC and SunTower concepts); however, others will require basic technology advances to realize (e.g., the solar-pumped laser and orbiting solar reflector concepts).

Although further study might provide additional insight, it is the judgment of the IAA study that the three SPS types selected for the current study were appropriately chosen, and that the examined alternative architectures do not represent superior options that should have been selected.

2.5 Solar Power Satellite Systems Trade Space Summary & Assessment

The three types of SPS examined by the IAA study have both similarities and distinctive characteristics. These include:

- Wireless Power Transmission
 - WPT Beam Generation
 - Solid State / Microwave: SPS Type I and SPS Type III
 - Solid State / Laser: SPS Type II
 - WPT Transmission Pointing
 - Coarse Pointing
 - Electronic Beam Steering: SPS Type III
 - Mechanical Beam Pointing: SPS Type I & SPS Type II
 - Fine Pointing
 - Electronic Beam Steering: SPS Type III, Type I
 - Mechanical Beam Pointing (w/ Feedback): SPS Type II
- Solar Power Generation
 - PV Conversion Type
 - Multibandgap PV: SPS Type II and SPS Type III
 - Amorphous Si PV: SPS Type I
 - Optical Systems
 - No Optical Systems: SPS Type I
 - Concentrator Optics: SPS Type II and SPS Type III
- Power Management and Distribution
 - High Voltage: SPS Type I (> 10,000 V)
 - Moderate Voltage: SPS Type II (> 1,000 V)

- Low Voltage: SPS Type III (< 100 V)
- Thermal Management Systems
 - High Temperature / Centralized Waste Heat: SPS Type I and SPS Type II
 - Note: Type I TMS may be passive; Type II TMS must be active
 - Low- to Moderate- Temperature / Decentralized: SPS Type III
- SPS Platform Systems – Modularity
 - High Modularity: SPS Type II (100s-1000s) and SPS Type III (10,000s)
 - Low Modularity: SPS Type I (1s-10s)
- SPS Platform Systems – Attitude Control / On-Board Propulsion
 - Gravity Gradient Stabilized: SPS Type III (Hybrid)
 - 3-Axis Stabilized: SPS Type I and SPS Type II
- SPS Platform Systems – Structural Systems
 - Passive Structural Systems: SPS Type II and SPS Type III
 - Active Structures (Large Gimbals): SPS Type I
- Ground Energy Systems
 - Receiver Type:
 - Microwave Rectenna: SPS Type I and SPS Type III
 - Tailored Bandgap PV: SPS Type II
 - Dual-Use of Receiver Area:
 - Space and Ground Solar Integration: All Types
 - SSP and Other Land Use: SPS Type I and SPS Type III

Summary Observations

The three SPS concept types examined by the IAA study span effectively a wide range of SSP architecture options. These several systems types include a range of similarities and differences, described above, depending on the specific topic of interest within the trade space.

The IAA concurs with the findings of previous groups, including the US National Academy of Sciences: Solar Power Satellites are technically feasible. There are no fundamental technical barriers that would prevent the realization of large SPS platforms during the coming decades.

However, questions remain as to economic viability. An early result of the IAA SSP study was the selection of only three basic systems types for detailed examination. (The limited resources available to the study necessitated this course.) The results of the study suggest this early decision was appropriate; however, alternative SPS systems / architecture concepts may warrant future consideration.

The next Chapter discusses the several key supporting systems and infrastructures that will be necessary for solar power satellites.

CHAPTER 3

SPS SUPPORTING SYSTEMS

In addition to the SPS platform itself, there is a range of supporting systems that must be developed, deployed and operated economically for cost-effective energy to be delivered to markets on Earth. These include:

- Earth-to-Orbit (ETO) Transportation,
- Affordable In-Space Transportation,
- In-Space Assembly, Maintenance and Servicing, and
- Ground Energy and Interface Systems.

In addition, an area of technology of potential value in improving the economics of space solar power in the long term is:

- In-Space Resources and Manufacturing

Descriptions of the principal technical approaches that appear feasible are presented in the following sections, as well as the key challenges for each. The chapter concludes with a summary of the trade space of supporting systems and a high-level technology assessment of the options.

Timeframes. The IAA assessment of future capabilities examines two prospective timeframes. The “nearer-term” refers to capabilities that could enter operations during the coming 10-20 years. The “farther term” refers to capabilities that are unlikely to be feasible sooner than 20-30 years from the present. Questions of technology maturation and budget requirements are discussed in Chapters 4 and 6 respectively.

3.1 Earth-to-Orbit Transportation

Earth-to-orbit (ETO) transportation has been widely recognized as a critical capability for large, ambitious future space projects, such as space solar power. Beginning in the 1970s, ETO transport has been examined in various SPS study efforts. Candidate solutions have ranged from extremely large expendable or reusable launchers, to smaller scale highly reusable launchers beginning with the Fresh Look study in 1995-1997 (enabled by the highly modular, self-assembling SPS architectures that were first developed at that time). The topic is an enormous one, spanning numerous systems concepts, diverse technology alternatives and various prospective

market scenarios. Not surprisingly, the treatment of this critical topic by the IAA study was relatively modest, due to the IAA focus on SSP *per se* and the limited duration and scope of the study.

Primary ETO Functional Requirements. The key requirements that an ETO system for SPS launch must provide include the following:

- Transportation to LEO or GTO at less than \$500-\$1,000 per kilogram
- For Type I SPS, Launch to LEO of Payloads of not less than (NLT) 150-200 MT mass
- For Type II and Type III SPS, Launch to LEO or GTO of Payloads of not less than (NLT) 15-25 MT mass

Key SSP / ETO Technical Design Trades. The key technical issues that must be addressed for SPS ETO system development include:

- Propulsion Performance, including
 - The Thrust-to-Weight (T/W) and T/W design margin for the ETO propulsion system
 - The Specific Impulse (Isp) of the ETO propulsion system (i.e., the fuel efficiency)
- Architecture Level Issues, including
 - Expendability vs. Reusability of Systems
 - The cost of SSP IST transportation to be supported (particularly the cost of launching fuel for IST systems)
 - Scope and Cost of any supporting in-space infrastructure (e.g., in-space refueling depot(s), space assembly, maintenance and servicing systems for IST, etc.)
- For Reusable ETO Systems,
 - Fractional expendability of the hardware system per mission
 - Utilization of fixed capacity (i.e., roundtrip time from Earth to LEO, and/or the number of missions per year)
 - ETO Transportation System Lifetime
 - Probability of ETO mission/system failure
- Operations Related Issues, including
 - Operational hazards and/or issues (e.g., orbital debris in LEO, dwell time in LEO, etc.)

- Mission operations and sustaining engineering labor costs
- Supporting systems and infrastructure costs (e.g., supporting communications network costs)
- End-to-End logistics infrastructure and operations

Figure 3-1 provides a conceptual summary of these diverse issues and their interactions. Options to accomplish these launch objectives fall broadly into nearer-term and farther-term alternatives; these options are sketched in the paragraphs that follow.

Figure 3-1 ETO Transportation Systems Trade Space Interactions¹⁶

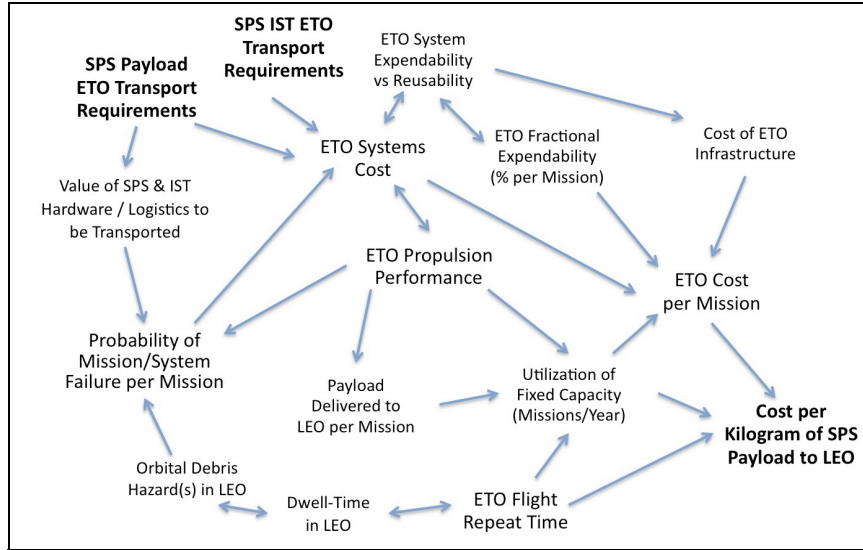

Credit: Artemis Innovation Management Solutions LLC, 2010

At a fundamental level, the minimum cost for ETO transport cannot be less than the cost of the energy required to achieve low Earth orbit. Assuming a change in velocity from the surface to LEO of approximately 9,000 meters/second, and a factor of 3:1 for thermodynamic efficiency (fuel-energy in versus velocity out), for each kilogram the energy required is some 121,500,000 Joules – equivalent to a little more than 33 kilowatt-hours. At a price of 10¢/kilowatt-hour, this would be equivalent to a cost

¹⁶ Note that in this figure, and all others of this type, the arrows indicate dependencies, and the predominant direction of the dependency.

contribution of about \$3.30 per kilogram. Hence, there is no fundamental barrier in terms of the cost of the energy to reach LEO; however, there are significant challenges in the engineering of low cost access to space

In the sections that follow, several ETO options are examined for the nearer-term, the mid-term, and the far-term.

ETO Systems Options – Nearer Term

The concept of Reusable Launch Vehicles (RLVs) has been examined extensively for SPS launch during the past four decades. During the 1970s, SPS studies identified the need for large, fully reusable two-stage to orbit (TSTO) launch vehicles to enable economically viable solar energy from space. Figure 3-2 presents a conceptual illustration of one such concept, including a size comparison of this concept to the U.S. space shuttle, which indicates the tremendous difference in scale between these space transportation system concepts.

Figure 3-2 1979 Reference System SPS TSTO ETO Transportation

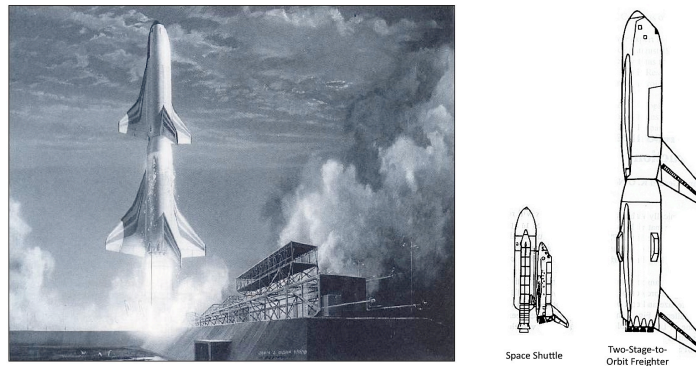

Credit: NASA Art

This very large-scale, TSTO approach was planned to launch payloads of more than 250 MT into LEO, with a GLOW estimated to be as high as 11,000 MT. The facilities required to support these enormous HLLVs were extremely large as well and entailed extensive operations and maintenance (O&M). Nevertheless, the ETO cost per kilogram of payload for these launch systems was projected at an exceptionally — and almost certainly unrealistically — low figure: about \$50-\$100/kg (in 1979 US dollars). A more credible estimate for the recurring cost per kilogram of

payload of a first generation, 99% reusable single-stage-to-orbit (SSTO) vehicle has been estimated to be about \$2000 per kilogram.^{xxii}

More recent assessments^{xxiii} suggest that early solar power satellite projects such as an initial pilot plant, or systems designed to serve so-called premium niche markets (PNMs; see Chapter 6) could be most cost-effectively launched using a mass-produced expendable launch vehicle (ELV). There are several low-cost ELV projects underway that might well serve this application. This strategy of early ELV use has the potential to eliminate a key barrier to previous SPS strategies in which large initial investments in new launch systems (and other infrastructure) were essential to progress.

ETO Systems Options – Mid-Term

If SPS are to be economically viable in the mid-term timeframe, then it will only be due to the availability of affordable Earth-to-orbit (ETO) systems options. In the mid-to-late 1990s, NASA’s Highly Reusable Space Transportation (HRST) study examined a wide range of options for dramatic reductions in the cost of access to space that might be achieved in the mid- to far-term.^{xxiv} This study was focused on the question: how might payloads in the 10,000-20,000 kg class be launched to LEO for costs as low as \$200/kg? The types of payloads that comprised the launch requirements for the HRST study included bulk materials (e.g., propellants), fragile space systems (e.g., conventional spacecraft, SPS or other platform system elements), and astronauts. The fundamental findings of the study were (1) expendable launch vehicles will not be able to accomplish the exceptionally low cost launch costs required; (2) in order to realize very low cost/kg, reusable systems must be highly reusable (i.e., with more than 1,000 flights per airframe); and, (3) a key driver of low maintenance and high reusability is the operational margin for key systems (such as propulsion).

Various systems options and vehicle technologies were highlighted by the HRST study. Some of the most promising included advanced materials for cryogenic engines that might enable higher thrust-to-weight (T/W) than that of existing engines, novel engine cycles (such as rocket based combined cycle (RBCC)), and new materials for vehicle structures and thermal protection systems (TPS).

The concept of “launch assist” in which some portion of the total energy needed to reach orbit could be off-board from the primary vehicle

(e.g., in the form of a catapult concept, or air launch) was found to be particularly promising. Figure 3-3 presents a conceptual illustration of one of the more promising systems concepts (which employed launch assist) that emerged from NASA's HRST study, the Argus-MagLifter combination.

Figure 3-3 Launch-Assisted SSTO ETO Transport Concept



Credit: NASA Art, by P. Rawlings / SAIC c. 1996

The strategic goal of lowering launch costs dramatically would be attained in this concept by using an EM launch assist (the MagLifter) to initially accelerate an RBCC vehicle (Argus) to just below the speed of sound, at which point it would be released for ascent to orbit.

Several near- to mid- term launch system concepts appear to be capable of ETO transport to LEO at specific costs below \$500 to \$1,000 per kilogram, depending on the launch rates achieved. Not surprisingly, however, this is an area that requires far greater study than was possible as part of the IAA study effort.

ETO Systems Options – Farther-Term

There are several infrastructure-intensive ETO systems options that are typically cited as options in the far term. One interesting concept for the farther term is the idea of electromagnetic (EM) launch directly to Earth orbit. In the past decade, Dr. James Powell has proposed a unique

approach that employs an entirely ground-based approach using superconducting magnetic levitation (Maglev).^{xv}

This concept, called “StarTram” is illustrated in Figure 3-4. In the case of the StarTram concept, a long low-acceleration maglev system accelerates a vehicle (with payload) to be launched to orbital velocities inside an evacuated tube. This tube is initially underground (during the acceleration portion of the track, which is the most massive), and then reaches up – eventually to some 20 km above the ground – via a superconducting magnetic levitation system.

Another such option is the idea of the “Space Elevator”, in which an extremely huge structure – extending from the Earth’s surface to GEO and far beyond – that would literally enable elevator-type cars to travel from Earth to space. (This very challenging concept depends upon assembling a structure of about 70,000 km in length that is capable of enduring for decades the intense radiation environment of the Van Allen belts, and able to maneuver to evade orbiting spacecraft and large debris.) Other options include various interim concepts, such as rotating tethers to create a “skyhook” approach, and farther term alternatives, such as the “launch loop”.

Another class of advanced ETO systems involving ground-to-vehicle beamed power (e.g. with high intensity lasers) does not appear to be promising for SPS applications. This assessment is due in large measure to the quite modest payloads (i.e., below 100-1,000 kg) that are likely to be enabled by such systems are not generally useful for SPS launch.

Figure 3-4 The Direct-to-Orbit EM Launch Concept: StarTram

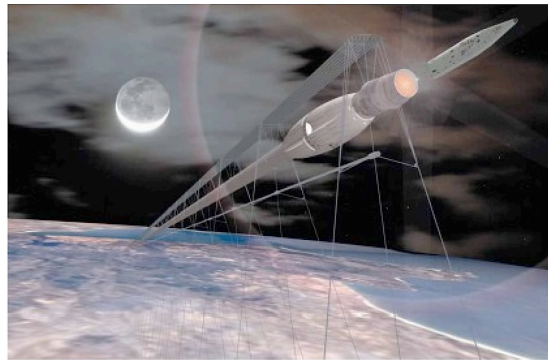

Credit: Art Courtesy Dr. James R. Powell

Some of the above concepts hold out the promise of launch to space for extremely low marginal costs – about equal to the cost of the electricity required. However, it is the judgment of the IAA that considerably more R&D is needed to establish the technical feasibility of the known far-term launch concepts.

ETO Transportation Assessment Results

The required “specific cost” for SPS ETO services depends very much on the price point for the energy to be delivered, and the market involved. There are also significant potential synergisms involved among future launch markets. For example, the NASA Commercial Space Transportation Study (CSTS) examined the overall economics of advanced ETO transportation systems in more detail in the early 1990s.^{xxvi} A key finding of the CSTS study (conducted before the emergence of public space travel (PST) as a real prospect) was that there are tremendous potential markets that may emerge if, and only if launch costs fall below \$1,000-\$2,000 per kilogram.

It appears that the prospects are good for future capabilities that could achieve ETO costs less than \$500 - \$1,000 per kilogram with high launch rates. Additional R&D is needed to establish which approach is most promising. However, during the coming decade, costs of access to space will remain considerably higher. During the period beginning 20 years or more (from 2010), there are promising options for ETO at \$300-\$600 per kilogram or less. However, these depend on significant increases (10-fold to 100-fold) over 2010 launch rates.

Chapter 7 (Section 7.4) provides the results of the IAA study’s high-level systems analysis of the ETO transportation challenge.

3.2 In-Space Transportation

ETO transportation is frequently identified as critical to economically viable SPS. However, affordable and reliability In-Space transportation (IST) is equally important: LEO may be “half-way to anywhere”, however, reaching GEO is essential for the SPS concepts under study. The key technical issues for SSP in-space transportation (IST) revolve almost equally around (a) technical performance, (b) integration into the system-of-systems

(including supporting infrastructure), and (c) concept-of-operations (CONOPS) related questions.

Primary SPS IST Functional Requirements. The primary functional requirements that an SPS-supporting IST system must satisfy include the following:

- Transportation from LEO to GEO at less than \$500-\$1,000 per kilogram
- For Type I SPS (Microwave Classic, Updated), Transportation of SPS system components (for assembly in GEO), with varying mass, up to approximately 100 tons.
- For Type II SPS (Laser Electric), Transportation of SPS system major modules (for self-assembly in GEO), with largely uniform mass, anticipated to be approximately 50-100 tons.
- For Type III SPS (Modular Sandwich), Transportation of exceptionally large numbers of SPS system modules in several classes such as pieces of the RF transmitter array (for assembly in GEO), with a handful of specific mass types, up to approximately 10 tons (including the option of multiple modules being combined for a single launch and transport to GEO flight).

Key SSP / IST Technical Design Trades. The key technical issues include:

- Propulsion Performance, including
 - The Specific Impulse (Isp) of the IST propulsion system (i.e., the fuel efficiency)
- Architecture Level Issues, including
 - Expendability vs. Reusability of Systems
 - The cost of supporting ETO transportation (particularly the cost of launching fuel for IST systems)
 - Scope and Cost of supporting in-space infrastructure (e.g., in-space refueling depot(s), space assembly, maintenance and servicing systems for IST, etc.)
- For Reusable IST Systems,
 - Fractional expendability of the hardware system per mission

- Utilization of fixed capacity (i.e., roundtrip time from LEO-to-GEO-to-LEO, or the number of missions per year)
- IST System Lifetime
- Probability of mission/system failure
- Operations Related Issues, including
 - Operational hazards and/or issues (e.g., orbital debris in LEO, dwell time in LEO, etc.)
 - Mission operations and sustaining engineering labor costs
 - Supporting systems and infrastructure costs (e.g., supporting communications network costs)
- End-to-End logistics infrastructure and operations

Figure 3-5 provides a conceptual summary of these diverse issues and their interactions.

Figure 3-5 In-Space Transportation Trade Space Interactions

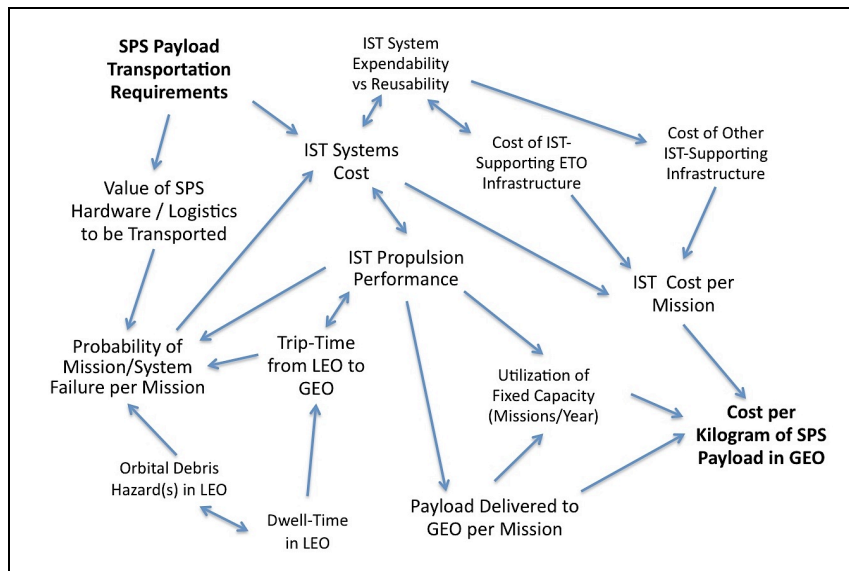

Credit: Artemis Innovation Management Solutions LLC, 2010

The principal systems options for in-space transportation include: (a) expendable transportation; (b) reusable transportation using high-energy cryogenic propulsion; (c) reusable transportation using solar electric propulsion; and (d) infrastructure-based in-space transport involving the use

of space-based tethers. Particular systems options may be expected to become available in either the near-to-mid term, or in the far-term.

Systems Options – Nearer Term

There are a handful of potential systems options that are viable in the nearer-term; these include the following:

- IST transportation using high-thrust/high-energy chemical propulsion
 - This option involves short trip times typically, but also relatively high requirements for fuel consumption
 - This might involve either Expendable (one-way) or reusable (round-trip with refueling) systems options
 - Typically this option would involve the use of cryogenic propellants (e.g., liquid oxygen (LOX) and liquid hydrogen (LH2))
- Reusable transportation using moderate- to high- power level solar electric propulsion (SEP).¹⁷

In the reusable space transportation cases above, a critical element of supporting infrastructure is the capability to refuel the vehicles involved.

Systems Options – Farther-Term

In the farther term, advanced concepts using various advanced technologies, including rotating space tethers appear promising for in-space transportation. Some of the concepts include:

- Reusable transportation using moderate- to high- power solar electric propulsion;
- Infrastructure-based in-space transport involving the use of space-based tethers (either rotating or electrodynamic tethers); and,
- Hybrid concepts involving combinations of high-thrust electric or EM propulsion for payload transport and low-thrust / high-efficiency options for re-boost of infrastructures.
- Alternative options, including solar thermal propulsion (STP) and nuclear thermal propulsion (NTP). (These options must be examined

¹⁷ A critical question will be that of balancing the need for high fuel efficiency with reasonable trip times. A low power SEP approach may be fuel-efficient, but it would require very slow trips – and resulting poor utilization of fixed capacity in terms of overall economics. This is a key topic for future studies of SPS in-space transportation.

more carefully, however, to verify not only engineering performance, but also the viability of the detailed concepts of operations.)

In addition, effective integration with ETO launch systems in the far term will be an important requirement for new in-space transports. (For example, a sub-orbital vehicle might be integrated with a “sky-hook” tether.)

In-Space Transportation Assessment Results

The topic of in-space transportation has been examined very, very broadly by diverse studies during the past five decades. The cursory examination by the IAA SSP study has found that there are a number of good prospects for significant reductions in the costs of in-space transportation during the coming two decades. For the near- to mid- term, concepts involving high-efficiency and low-cost solar electric propulsion (SEP) appear to be the most promising.

Chapter 7 provides the results of the IAA study’s high-level systems analysis of challenge of affordable in-space transportation.

3.5 Space Assembly, Maintenance and Servicing

The most important question vis-à-vis space assembly, maintenance and servicing (SAMS) for SPS is whether or not one or more stand-alone, dedicated orbiting platforms are needed to enable a specific SPS architecture. For example, in the case of the SPS 1979 Reference System architecture (see Figure 2-3), dedicated platforms in both LEO and GEO were required. However, in most concepts developed since the mid-1990s, a greater or lesser degree of “self-assembly” is typically assumed.

Systems Options – Nearer Term

There are several promising systems options for SAMS in the nearer term. For example, autonomous rendezvous and docking (AR&D) is an essential functionality for SPS assembly in the near term. In addition, tele-operated robotic capabilities for SAMS that can be readily anticipated in the near-term are consistent with ambitious functionality for SPS assembly and operations. In addition, fully autonomous robotics also may be achievable if they are implemented in highly structured environments.

In other words, autonomous robotics could be implemented soon, if done with adequate beacons, visual cues, and regular features for image

recognition. The development of such SAMS systems would require explicit coordinated design with existing space structural systems technologies (e.g., kinematically-deployed structures), as well as concurrent design of new interconnects, avionics and platform dynamics and attitude control systems.

Systems Options – Farther-Term

In the farther term, large space systems such as SPS will likely be increasingly capable of SAMS involving unstructured environments, enabling fully autonomous operations. In addition, a wide range of new materials and structures options may be expected to emerge in the far term – particularly involving novel technologies such as extremely large membrane systems, or superconducting magnetically-inflated cables (i.e., “MIC”).^{xxvii}

Space Assembly, Maintenance and Servicing Assessment Results

Overall, the engineering challenge of space assembly, maintenance and servicing for solar power satellites appears to be technically feasible. A number of challenges remain of course, some of them significant. For example, excessive mass and cost for these systems may be highly detrimental to overall SPS economics (and energy payback times). These issues should be examined in greater detail by future studies. Overall, it is particularly important that SAMS technologies be developed in close coordination with the development of SPS platform and IST systems and technologies, including materials and structural systems, interconnects, and controls structures interactions (CSI) technology.

3.4 Ground Energy and Interface Systems

There are three primary types of ground energy and interface systems (GEIS) for SPS architectures. These are (1) direct integration with a local power grid to deliver baseload power; (2) periodic integration into one or more premium niche markets (PNMs);¹⁸ and (3) production of fuels and other chemicals.

Systems Options – Nearer Term

Essentially all key capabilities for SPS ground energy and interface systems can be realized in the near term. However, there is a strong need to

¹⁸ The idea of “premium niche markets” is discussed in Chapter 6.

achieve the lowest possible cost for these systems, as well as the greatest level of seamless integration with ground infrastructures; these may entail the development of selected new technologies (including low-cost manufacturing techniques for receiver systems). The principal systems options for ground energy and interface systems include the following:

- Direct Integration of SPS rectenna-derived power with a local power grid (including “smart grid” integration in the event the power delivered may vary to allow support to one or more markets during a given period of time);
- Periodic integration of SPS rectenna-derived power into one or more PNMs;
- Time-Phased mixing of SPS rectenna-derived power with local ground based solar power, and the integration the resulting power supply with either a local “smart grid” or into one or more PNMs; and,
- Production of fuels and other chemicals of value.

Systems Options – Farther-Term

No major systems options for GEIS are intractable in the nearer term; as a result, only modest advances are likely to be delayed to the farther term. These advances are likely to involve improvements in the efficiency and cost of initial receiver systems.

Integration of SSP WPT Receivers

An important point of comparison between several SSP architectural and technology options is that of the integration of the ground segment of the WPT system. Key questions concerning the degree to which the land used for the SPS receiver might also be made available for dual purpose applications, including agriculture, grazing, etc. As noted, a related question is whether the ground receiver for the WPT energy may be integrated with ground solar power generation. Specific technical design questions related to this issue include (a) can the WPT receiver system allow more than 70% of the ambient light to reach the ground (allowing dual use of the land under the receiver), and (b) can the receiver be deployed in an all-weather, elevated (e.g., 10 meters above the ground) configuration to enable agriculture, etc.?

A laser-PV system (oriented toward GEO) will allow little ambient sunlight to reach the ground without significantly “over-spacing” the array elements (which would waste expensive WPT transmitted power). A

microwave system, however, can support both high elevation above the ground and more than 70%-80% transparency to incident sunlight.

There are two alternative options for the integration of space and ground solar power in a dual-use land scenario. First, the PV arrays used to collect power from the incoming laser WPT transmission may also be used to generate power from sunlight when it is available. (This option was examined in some detail by ESA in their SSP studies circa 2003-2004). Second, PV arrays may be co-located with elevated mesh-type microwave rectenna receivers. (This option has not yet been examined in any detail.)

Ground Energy and Interface Systems Assessment Results

There appear to be no “show-stoppers” in GEIS for the technical realization of SPS for any of the three types examined by the IAA study. There are acceptable alternatives for the integration of both space solar power and ground solar power for both microwave WPT and laser WPT cases. However, the microwave WPT cases appear to have a potential advantage in enabling more generic and diverse dual-purpose utilization of the land area underneath the SPS WPT ground receiver site.

3.5 In-Space Resources and Manufacturing

Three key issues related to in-space resources have been examined by the IAA study. These are (1) the capability to operate over extended periods of time on the lunar surface without recourse to expensive and problematic radioisotope power and thermal systems; (2) the capability to “boot strap” lunar operations through the local manufacturing of key systems; and, (3) the capability for low cost launch from the lunar surface.

The difference in the respective gravity wells of the Earth, Moon and other bodies is the reason why extraterrestrial resources are of potential interest for future space commercialization – including SPS. Figure 3-6 illustrates these differences. This difference in gravity wells corresponds to a delta-velocity required for ETO of about 9,000-10,000 meters per second, versus for launch from the lunar surface of only about 1,800-1,900 meters per second.

However, even though the gravity well of the Moon is modest compared to that of Earth, if lunar-derived resources are to someday play a role in the manufacture and/or servicing of SPS, then exceptionally low

cost transportation will be required from the surface of the Moon to GEO. One option to accomplish this goal is to construct an EM maglev launch system on the lunar surface.^{xxviii}

Such a system could launch payloads either to low Lunar orbit (LLO) or to an escape trajectory, for power levels of about 2 GW and a total length of perhaps 50 – 150 km on the lunar surface.

Figure 3-6 Gravity Well Comparisons: Earth, Mars and the Moon

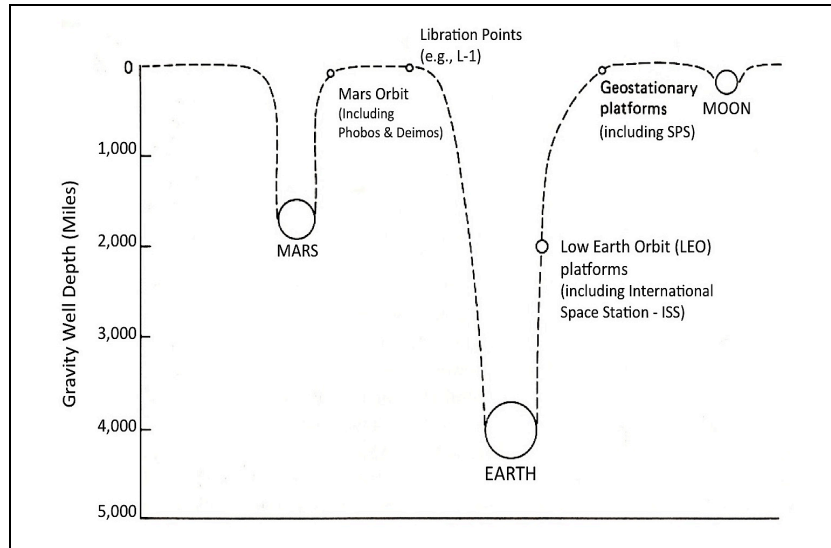

Credit: Artemis Innovation Management Solutions LLC

Two critical first steps in any industrialization of lunar resources will be (a) achieving broad ranging access to, and operations across the lunar surface without recourse to nuclear power sources,¹⁹ and (b) establishing self-sufficient, economically driven production of increasing quantities of energy on the surface of the Moon. The University of Houston and others

¹⁹ Note: RTGs and RHUs (radioisotope thermoelectric generators and radioisotope heat units) or more advanced technologies such as DIPS (dynamic isotope power systems) or SNRs (space nuclear reactors) are often used where appropriate for high priority government science missions. However, these nuclear technologies may not be to be economically viable for large-scale, multi-vehicle commercial operations on the Moon. Hence, it is possible that other solar-based options may be required for lunar commercialization, including SPS related operations. However, this has not been considered in detail by the present study. This is a topic that warrants future consideration by a future study group that is chartered to examine and compare a range of space energy options for future missions.

have explored the idea of local fabrication of PV cells and solar arrays from the materials of the lunar regolith.^{xxix} The issue of broad access without nuclear sources is difficult to solve. One potential solution has been proposed by R. Wegeng (of the Battelle Memorial Institute) and J. Mankins (of Artemis Innovation Management Solutions LLC); it involves the fabrication of numerous thermal energy reservoirs from the lunar regolith that could enable continuous warmth during overnight stays on the Moon without radioisotopes.

There has been considerable discussion during recent years (2008-2009) regarding prospects for harvesting chemical propellants from the lunar surface (for example, the potential of lunar ice in the shadowed regions of the Moon). However, this idea depends upon low cost launch from the Moon – and using up the propellants that are intended for export instead for launch may not prove economically viable. As mentioned previously, electromagnetic launch assist, using a low-acceleration magnetic levitation (MagLev) system, represents a generally more promising approach for this purpose.^{xxx}

Systems Options – Nearer Term

At present, there do not appear to be any lunar products that might be developed and available for application in SPS system applications (including demonstration and SPS pilot plants) in the nearer-term – i.e., in the coming decade-plus.

Systems Options – Mid-to-Far Term

Selected lunar products might be feasible in the mid term – however, the use of these for SPS will depend entirely on the availability of low cost launch from the lunar surface. Such products could include propellants and simple extracted materials (e.g., processed regolith) for use in radiation shielding, etc. These initial products appear to be equally applicable to any of the three types of SPS concepts examined. There are no technical barriers to the introduction of products developed from asteroids or other small bodies; however, it appears unlikely that the required transportation infrastructure will be available to enable such development.

In the farther term, a broad range of lunar and/or near-Earth object derived products could be introduced into a space solar power industry. These could include the products noted for the nearer term, as well as more complex manufactured items such as structural elements, thin-film

concentrator components, various optical systems, etc. Overall, the types of manufactured elements that could be readily introduced into an SPS would seem to favor Types I and III examined in this assessment (the microwave options), particularly Type I. The Type II SPS concept (laser electric) appears to have fewer opportunities for the introduction of more complex extraterrestrial manufactured products.

In-Space Resources and Manufacturing Assessment Results

The introduction of materials and manufactured items from extraterrestrial sources holds great promise for SPS systems and operations in the far term. There are no fundamental technical barriers in terms of required supporting systems to the realization of solar power satellites. However, it is rather unlikely that such capabilities can be realized in the nearer term to a significant degree.

3.6 SPS Supporting Systems Trade Space Summary and Assessment

Trade Space Summary

This chapter has examined the supporting systems required for solar power satellites. The three types of SPS examined by the IAA study have both similarities and distinctive characteristics with regard to required supporting systems. These include the following:

- Launch Vehicles
 - Heavy Lift Launch Vehicles: SPS Type I or SPS Type II
 - Moderate Lift Launch Vehicles and Greater: SPS Type II or SPS Type III
 - Small Lift Launch Vehicles and Greater: SPS Type III
- In-Space Transportation
 - Large Scale In-Space Transport: SPS Type I & SPS Type II
 - Moderate Scale In-Space Transport: SPS Type III
- In-Space Infrastructure
 - General
 - Large-Scale Infrastructure: SPS Type I
 - Low- to Moderate- Scale Infrastructure: SPS Type II and SPS Type III
 - Space Assembly, Maintenance and Servicing

- Stand-alone SAMS Systems: SPS Type I
- On-Board Platform SAMS Systems: SPS Type II and SPS Type III
- Self-Assembling SPS Systems: SPS Type II and SPS Type III
- In-Space Resources and Manufacturing
 - Use of Simple Products (e.g., Fuels): All SPS Types
 - Use of Manufactured Products: SPS Type I and SPS Type II

Assessment Summary

The three SPS concept types examined span effectively a wide range of required supporting system choices and options. These systems include a range of similarities and differences, depending on the specific topic of interest within the trade space. There are no fundamental “show-stoppers” among the required supporting systems (i.e., no technical barriers that would prevent the realization of large-scale SPS platforms during the coming decades). However, as noted, there are key challenges in achieving the very low cost operations needed to achieve economically viable SPS.

The next Chapter presents a summary technology readiness and risk assessment (TRRA) for the three SPS Types that were evaluated, as well as for supporting systems.

CHAPTER 4

TECHNOLOGY READINESS AND RISK ASSESSMENT

A central question posed for the IAA study was whether solar power satellites are feasible. This question has two aspects: technical feasibility and economic viability. Both of these issues depend upon the figures of merit (FOM) – both engineering and cost related – for the various systems and technologies. Also, there is the question of whether or not the technologies needed for various concepts are “at hand”, or require additional R&D to achieve necessary FOMs and high level of maturity.

4.1 Technology Readiness and Risk Assessment Methodology

The IAA study employed a formal technology readiness and risk assessment (TRRA) methodology; the foundation of which was the standard Technology Readiness Level (TRL) scale in evaluating the level of maturity of various SPS technologies. Additional tools for technology assessment included the Research and Development Degree of Difficulty (R&D³) for each technology area, and the Technology Need Value (TNV). The following paragraphs provide additional information regarding the TRRA methodology used.

*Technology Readiness Levels (TRLs)*²⁰

The technology readiness levels (TRLs) are a standardized technology discipline-independent set of metrics used for evaluating the maturity of a particular technology. NASA first defined the TRL scale in the 1970s, and refined and codified a formal set of definitions in the 1990s.^{xxxii} It ranges from the beginnings of basic scientific knowledge of a new phenomenon to the completion of specific system applications and missions. Appendix C (Section C.1) provides a detailed summary of the TRL scale. The IAA study used the TRL scale to assess the current status of SPS-relevant

²⁰ Mr. Stanley Sadin of the NASA Office of Aeronautics and Space Technology (OAST) first defined the TRL scale in the mid-1970s. Mr. John Mankins of NASA developed the formal definitions of the TRLs in 1995. During 2007-2009 an international working group (led by the ESA and CNES and with the participation of NASA, JAXA and CSA) formulated a standard definition of the TRLs.

technology and to forecast consistently the future development of those technologies.

Research and Development Degree of Difficulty (R&D³)

In addition to consideration of the current and future maturity of a given technology for a particular application, there is another question: how difficult will the needed R&D program be to accomplish? The Research and Development Degree of Difficulty (R&D³) metric, developed by NASA in the mid-1990s, was intended for this purpose. Appendix C (Section C.2) provides a detailed summary of the R&D³ scale.

Technology Need Value (TNV)

In addition to the TRL and R&D³ for a particular technology and prospective R&D effort, it is also important to characterize consistently the importance of that technology (and R&D) to a particular system and mission application. The “technology need value” (TNV) provides such a scale, and is used in the IAA study technology assessment. Appendix C (Section C.3) provides a detailed summary of the TNV scale.

Integrated TRRA Risk Matrix

The “risk matrix” is a standard analytical technique for graphically depicting the results of a risk assessment in the aerospace industry. The standard Risk Matrix displays along one axis the probability of some problem occurring in a system development effort, and along the second axis the consequences for the project if a given problem does occur.

The section that follows indicates which areas of technology for future SSP/SPS were included in the IAA study’s TRRA.

4.2 Identification of Key Technology Areas for Assessment

There are three classes of technology requirements that should be assessed in evaluating the readiness to proceed with space solar power systems development and deployment; these are:

- Class A: SPS System Concept Specific Technology Requirements. These technologies comprise those that are special to a particular SPS architectural choice. Specific technologies for the three system concepts types cited above (Paragraph 5.2) including the Classic Microwave SPS approach, the Integrated Modular Laser SPS approach, and the Modular Sandwich SPS concept.

- Class B: SPS System Platform Generic Technology Requirements.
These technology needs comprise those that are generally needed for all or most types of future SPS platform (although there may well be selected variations in the detailed specifications / FOMs for different architectural options).
- Class C: Supporting Infrastructure Specific Technology Requirements.
These technologies represent those needed for the several supporting infrastructures that will be required to accomplish any of the several approaches to SPS platforms.

Specific technology requirements within each of these three classes are delineated as shown in Table 4-1, on the page following.

4.3 SPS Concept Specific Technologies

Wireless Power Transmission

WPT Technology Overview. There are several key technologies needed for the primary WPT system options; these include (1) electron tube RF generating devices (such as magnetrons, gyrotrons, TWTs, etc.); (2) solid state RF generating devices (such as FET amplifiers); and (3) solid state laser generative devices (such as laser diode arrays). Other key component technologies include (for the solid state RF case), phase shifters, antennas, etc.

Key Figures of Merit. The following are the key FOMs for SPS WPT technologies.

- Electrical Power to WPT EM Beam Power Conversion Efficiency (Percentage);
- WPT EM Beam to DC Power Conversion Efficiency (Percentage);
- WPT Beam Power Generated per Kilogram of Platform Mass (kW-beam/kg);
- WPT Beam Power Generated per Unit Transmitter Area (kW-beam/Meter²);
- Angular Beam Control (Degrees);
- Angular Beam Control Response Time (Seconds to Full Angular Redirection);

- WPT Mean Time Between Failure (Expected Failures per Year of Operation); and,
- WPT Degradation per Unit Time (Percentage Decrease in Power Output per Year of Operation).

Table 4-1 SPS Key Technology Requirements

Class A SPS SYSTEM CONCEPT SPECIFIC TECHNOLOGY REQUIREMENTS			Class B SPS PLATFORM GENERIC TECHNOLOGY RQTS	Class C SUPPORTING INFRA-STRUCTURE TECH RQTS
μ Wave Classic	μ Wave Sandwich	Laser WPT		
μ Wave Amplifiers (Magnetron, FET, etc.)	High Efficiency FET Amplifiers	High Eff. Lasers	Large, Lightweight Structural Systems	Reusable Launch Vehicles (High TW Engines, TPS, Hot Structures, etc.)
		Diode		
		Fiber		
		Disc		
High Voltage PMAD	Beam Shaping & Control	Mid- to High-Voltage PMAD	In-Space Assembly & Construction (Robotics / Interfaces)	Affordable In-Space Transport (High TW Engines, TPS, EP, etc.)
High Power Rotating Couplers	Highly Modular Low Voltage PMAD	Near-Visible Beam Expanders	Modular GN&C / Avionics	In-Space Refueling (Cryogenics, EP Fuels, etc.)
Light Weight Large Area PV	Low mass Optics (w/ Reflectors)	High Temperature Electronics	Modular CMD / Communications	Precision AR&D (Autonomous Rendezvous & Docking)
Moderate Temp Thermal Management	High Temperature Electronics	High Temperature (Active) Thermal Management	High-Efficiency Photovoltaics (e.g., Multi-bandgap)	Ground Power Grid Interfaces and "Smart Grid" Operations
Fail Safe Beam Tracking & Control	Moderate Temp Thermal Management	High Efficiency Laser Receiver PV System	Radiation Tolerant Electronics	Complex System & Configuration Control
Low Cost Rectenna	Low Cost Rectenna	Precision Pointing Systems	Radiation Tolerant Photovoltaics	

TRRA Assessment Results. Appendix E presents the results of a preliminary assessment of key WPT technology options.

Solar Power Generation

SPG Technology Overview. There are a number of key technologies involved in solar power generation for future SPS platforms; these include: (1) multi-bandgap PV cells; (2) thin-film PV cells; and (3) conventional Si PV cells. Various associated component technologies include concentrator (and other) SPG optical systems, cell-level power management and distribution, cell supporting structural systems, cell-level thermal management systems, and others. For some architectural cases, other technology options include solar dynamic power conversion options (e.g., Sterling engines, Rankine Cycle engines, Brayton Cycle engines, etc.)

Key Figures of Merit. The following are the key FOMs for SPS WPT technologies.

- Incident Sunlight to Electrical Power Generation Efficiency (Watts-Incident/Watts-electric);
- Electrical Power Generation per Unit Mass Generated (Watts/kg);
- SPG Mean Time Between Failure (Expected Failures per Year of Operation); and,
- SPG Degradation per Unit Time (Percentage Decrease in Power Output per Year of Operation).

TRRA Assessment Results. Appendix E presents the results of a preliminary assessment of options for SPS solar power generation technologies.

Power Management and Distribution

PMAD Technology Overview. The major technology areas in the general category of power management and distribution include: (a) high voltage power cabling, (b) modular / intelligent power conversion, and (c) advanced power management options (e.g., superconductors); as indicated in the discussion of generic SPS system architectures in Chapter 2, these functional areas of PMAD technology may be further parsed into PMAD and TMS involved with SPG, the platform, or WPT, etc., depending on the specific SSP system concept under examination.

Key Figures of Merit. The following are the key FOMs for SPS Power Management and Distribution technologies.

- Percentage Power Lost per Unit Power Transmitted (Percentage);

- Power Transmitted per Unit Mass (kW/kg);
- Power Transmission / Management Voltage (Volts); and,
- PMAD Mean Time Between Failure (Expected Failures per Year of Operation).

TRRA Assessment Results. Appendix E presents the results of a preliminary assessment of key technology options for PMAD.

Thermal Management Systems

Thermal Management Systems Technology Overview. The major technology areas in the general category of thermal management systems include: (a) radiators, (b) thermal coatings, (c) active cooling (e.g., refrigeration), (d) thermal loops and heat pipes, and (e) advanced thermal management options (e.g., thermo-electric cooling, micro-channel cooling, etc.). As indicated in the discussion of generic SPS system architectures in Chapter 2, these functional areas of technology may be further parsed into TMS involved with SPG, the platform, or WPT, etc., depending on the specific SSP system concept that is being examined.

Key Figures of Merit. The following are the key FOMs for SPS Thermal Management Systems technologies.

- Percentage Power Lost per Unit Power Transmitted (Percentage);
- Power Lost per Unit Mass (kW/kg);
- Thermal Energy Radiated per Unit Area (kW-thermal/Meters²);
- Thermal Energy Radiated per Unit Mass (kW-thermal/kg);
- Equilibrium System Temperature (Degrees-Celsius or Degrees-Kelvin); and,
- TMS Mean Time Between Failure (Expected Failures per Year of Operation; i.e., MTBF).

TRRA Assessment Results. Appendix E presents the results of a preliminary assessment of key technology options for SPS TMS systems.

4.4 Platform Generic Technologies

There are a number of key technologies involved in performing the full range of generic platform functions for future solar power satellites; these include: (1) large, lightweight structural systems; (2) in-space assembly & construction (ISAAC), including robotics and interfaces; (3) modular

GN&C and/or avionics; (4) modular command and communications; (5) high-efficiency / radiation-tolerant electronics, PV and related systems; and, (6) systems autonomy.

Note that in the case of space structural systems, there will be a wide range of types of structures and materials required for each of the SPS concepts under consideration due the exceptionally large and complex character of the platforms involved; hence no single technology will be sufficient to enable SPS to be development and deployed successfully. The following are the some of the important figures of merit for SPS Platform technologies.

- Platform Mass per Unit Power (kg/kW),
 - Including power generated onboard, power transmitted, and power received on Earth at the receiver site;
- ISAAC Mass per Unit Platform Mass (kg-ISAAC/kg-Platform);
- Annual Labor Hours per Unit Platform Mass (hrs-Labor/kg-Platform per Year); and,
- TMS Mean Time Between Failure (Expected Failures per Year of Operation; i.e., MTBF).

Appendix E presents the results of a preliminary assessment of key options for SPS Generic Platform technologies.

4.5 Key SPS Supporting Systems Technologies

The large number of systems and technologies required to support SPS deployment and operations comprises a daunting prospect. As a consequence, the following sections provide no more than identification and a cursory assessment of the most important technology options.

Earth-to-Orbit Transportation

The future development of highly affordable and low-risk Earth-to-orbit (ETO) transportation systems is essential for most, if not all, ambitious future commercial development of space opportunities. And, of course, low-cost ETO transport is critical to the economic viability of full-scale SPS systems designed to deliver power into commercial terrestrial markets in the mid- to long- term. Not surprisingly, low-cost ETO transport will require the development, maturation and deployment of a number of new technologies.

This technology assessment comprises only a few of the specific R&D areas that may be needed to realize low-cost and highly reliable ETO for SPS (and, not all of these are required simultaneously for all types of reusable launch vehicles; “RLVs”). These capabilities include: (1) High-thrust advanced cryogenic rocket engines (ACRE) with large operational margins (e.g., using advanced materials components); (2) moderate thrust-to-weight rocket-based combined cycle (RBCC) or turbine-based combined cycle (TBCC) propulsion with large operational margins; (3) lightweight, 1000 flight class vehicle airframes; (4) durable, 1000 flight class thermal protection systems (TPS), (5) airplane class avionics and flight operations; (6) low-cost high-flight rate launch assist systems; and, (7) advanced launch concepts (e.g., maglev to orbit type concepts).^{xxxiii}

See Appendix E for the results of a preliminary assessment of key ETO transport technology options.

Affordable In-space Transportation

Almost as much as low-cost ETO transport, affordable and timely in-space transportation will be essential to a number of ambitious options for the future commercial development of space. This is particularly true for SPS options, in which all SPS systems and consumables must be transported from LEO to GEO for deployment.²¹ In addition to the transportation system, there are also a number of key supporting infrastructures that are enabling for AIST. For example, cryogenic propellant depots (CPDs), employing cryogenic fluid management (CFM) technology, are one critical systems-level technology for architectures that include high-energy cryogenic propulsion systems. See Appendix E for the results of a preliminary assessment of key technology options.

In-Space Assembly, Maintenance and Servicing

In-Space Assembly, Maintenance and Servicing (ISAMS) is another area of space technology that is going to be essential to numerous ambitious future commercial development of space. This is certainly true for exceptionally large solar power satellites, which will entail unprecedented levels of ISAMS activities in GEO (and in some cases also in LEO). Stand-alone ISAMS systems will operate in conjunction with onboard ISAAC systems (assessed in an earlier sections). See Appendix E for the

²¹ This is certainly the case prior to the potential introduction of extraterrestrial materials – discussed below.

results of a preliminary assessment of key in-space assembly, maintenance and servicing technology options.

Ground Energy and Interface Systems

There are several key technologies needed for the ground energy and interfaces systems, some of which are based on the primary WPT system options; these include (1) RF conversion via a rectenna, including both panel and mesh type rectennas; (2) band-gap tailored PV (for laser transmission); and, (3) direct radiant energy based thermo-chemical conversion systems. Other potentially important component technologies include, high efficiency grid integration transformers, rolling energy storage systems, etc. See Appendix E for the results of a preliminary assessment of key technology options related to ground energy and interface systems.

In-Space Resources and Manufacturing

The future use of in-space resources and in-space manufacturing of SPS systems and/or consumables represents an especially promising option for dramatically reductions in the life cycle costs of solar power satellites in the longer term. However, these capabilities will require the development, maturation and deployment of a range of specific new technologies before becoming feasible (much less economically advantageous). This technology assessment comprises only a few of the specific R&D areas that will be needed to realize in-space resources and manufacturing (ISRM) for SPS. These capabilities include: (1) Materials acquisition; (2) in-situ materials processing; (3) product manufacturing and packaging; and, (4) low-cost product transportation to SPS for utilization. See Appendix E for the results of a preliminary assessment of key technology options related to in-space resources and manufacturing.

4.6 Technology Readiness and Risk Assessment Summary

A preliminary technology assessment has been developed, based on the results of the study's efforts. Three factors were examined. The first factor was the level of technology maturity stated in terms of the standard Technology Readiness Levels (TRLs), the definitions of which are provided in the Appendices. The second factor was an initial assessment of the

expected degree of difficulty in achieving necessary R&D objectives in each of the technology areas. The final factor was the importance of each technology area to a particular systems, the “technology need value”).

These results are summarized in Table 4-2, Table 4-3 and Table 4-4, which follow. Please note that this TRA is highly simplified based on the scope of the study conducted; a more rigorous assessment requires a detailed systems analysis of various SPS platform options, as well as various supporting systems (e.g., ETO transportation). Figure 4-1 provides a diagrammatic version of these integrated technology readiness and risk assessment results in a risk matrix format.

In general, the cluster of key concept specific technologies for SPS Type-I are higher risk than those for Type-II or Type-III; while those for SPS Type-III are generally lower risk than the other concepts. There are outliers. The technology for an expendable HLLV in the case of SPS Type-I is notably lower risk than other technologies needed for that concept. Conversely, the technology for thermal management of the sandwich array is notably higher risk than the other technologies needed.

Figure 4-1 Integrated TRRA Matrix for SSP (Concept Specific Cases)

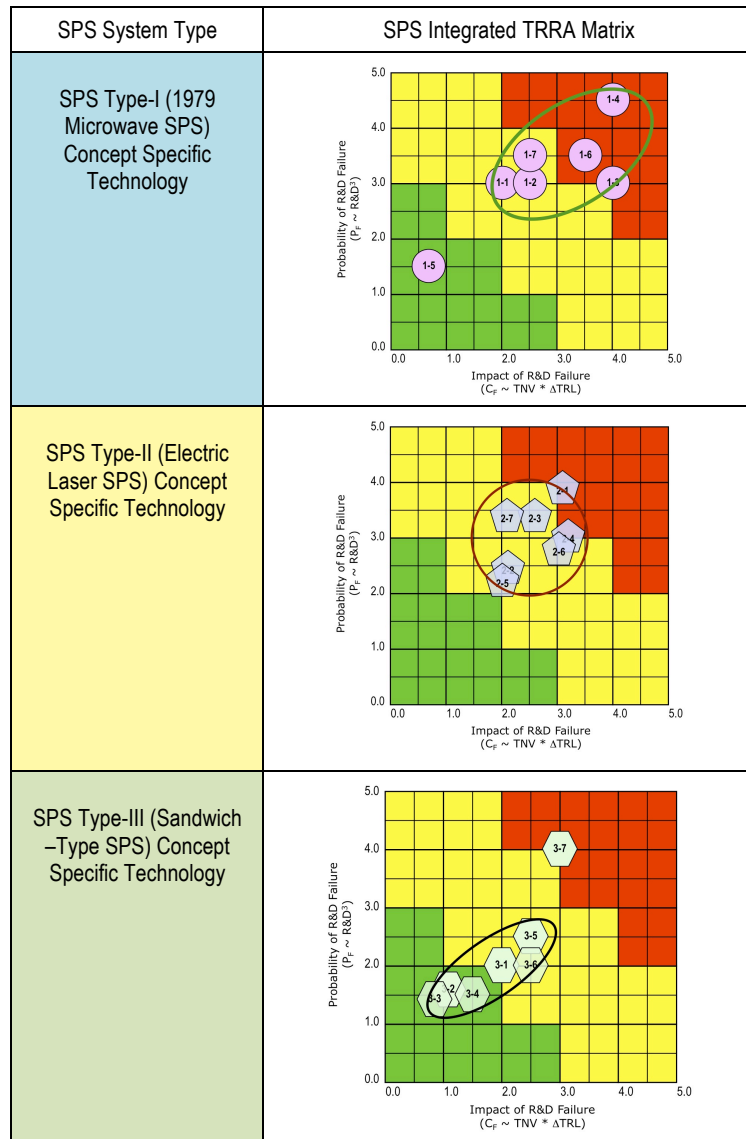

Table 4-2 SPS Type - Preliminary Technology Assessment²²

SPS Type	Technology Area	TRL (est.)	R&D3 (est.)	TNV (est)	Working Notes on Technology Requirements
SPS Type I - μ Wave Classic	μ Wave Amplifiers	5-6	1-2	2-3	Assumes use of microwave tube devices (e.g., Magnetrons) @ ~ 5 KW with Phase shifting with efficiency of about 80%
	Large Precision Waveguide Structures	3-4	2-3	3-4	Assumes ~ 1-2 cm flatness at about 1,000 meters diameter
	Moderate Temperature Thermal Management	4-5	2-3	3-4	Assumes waste heat of about 2-6 kW-thermal per square meter across the Transmitter
	High Power / High Voltage Rotating Couplers	2-3	4-5	4-5	Assumes 5,000-10,000 volts PMAD or greater, with transfer of ~ 1-7 GW across the gimbaling system
	Retrodirective Beam Control for Fine Pointing	5-6	2	4-5	Assumes phased shifting systems with electron tube option for WPT generation
	High Voltage PMAD	2-3	3-4	4-5	Assumes 5,000-10,000 volts PMAD or greater
	Light Weight Large Area PV (Separate fm WPT)	3-4	3-4	3-4	Requires total area at approximately 5 km x 10 km or more for each WPT system
SPS Type II - Laser WPT	High Efficiency Near Visible / IR Solid State Diode Laser Arrays	3-4	3-4	3-4	Assumes laser array transmission at less than 100 kW emitted beam per square meter for a single Laser Transmitter module
	Mid- to High- Voltage PMAD	4-5	2-3	4-5	Assumes 1,000 volts PMAD or greater, for less than 100 kW transmitted per SPS module
	Near-Visible Beam Expanders	3-4	4-5	1-2	Assumed moderated total beam intensity at in-space optics
	High Temperature Electronics	4	2-3	2-3	Assumes no active refrigeration of SPS WPT supporting electronics, operations at T > 100 °C
	Feedback based Beam Control for Fine Pointing	5	2-3	4-5	Assumes ground-based laser pilot signal, and closed loop control approach
	High Temp Thermal Management Systems	3-4	2-3	4-5	Assumes waste heat of about less than 10-50 kW-thermal per square meter on the radiator for a given transmitter module, with active laser cooling
SPS Type III - μ Wave Sandwich	FET Amplifiers	4-5	1-2	4-5	Assumes use of solid state amplifiers (e.g., FET) @ 50-100 Watts w/ Phase shifting @ ~80% efficiency
	Modular Low Voltage PMAD	5	1-2	2-3	Assumes PMAD voltage at about 50 volts
	Phase Shifters	5-6	1-2	4-5	Assumes phase shifting for overall beam steering at approx. \pm 7 degrees from GEO
	High-Efficiency CPV	5	1-2	4-5	Assumes CPV at about 50% conversion efficiency, with local optics
	Light Weight Solar Collector Structure	3-4	2-3	4-5	Assumes structural systems of 3-5 kilometers in scale, with very low mass
	Large Optical Solar Collection Systems	3-4	1-2	4-5	Assumes modular solar collection system, integrated with structure; individual mirrors at very low mass and high reflectivity
	Distributed Low Temp. Thermal Mgt. Systems	3	3-4	4-5	Assumes waste heat of about 1-4 kW-thermal per square meter across the Sandwich Array

²² The determination of the TRL depends upon the details of the system requirements to be met using the technology.

Table 4-3 SPS Generic Platform - Preliminary Technology Assessment

TECHNOLOGY AREA	TRL (est.)	R&D3 (est.)	TNV (est.)	Working Notes on Technology Requirements
Large, Lightweight Structural Systems	3-4	2-3	4-5	Assumes structural systems of 3-5 kilometers in scale, with very low mass; no mirrors
In-Space Assembly & Construction (Robotics / Interfaces)	4-5	1-3	2-4	Assumes highly structured environment for platform assembly operations; Assessment depends on SPS platform concept details
Modular GN&C / Avionics	3-4	1-2	2-3	Assumes applications of space-qualified modular avionics (e.g., FPGAs) capable of reprogramming on-orbit
Modular CMD / Communications	5-6	1-2	2-3	Assumes communications on-platform, space-to-space and space-to-Earth, with encrypted network approaches
High-Efficiency PV	4-5	1-2	3-4	Assumes efficiencies with concentrated sunlight at approximately 30%-50% or greater
Radiation Tolerant Electronics	4-5	1-2	3-4	Assumes 15 years or greater life time without replacement at GEO, with option for modular redundancy and reconfigurability / reprogramming
Radiation Tolerant PV and Related Power Systems	5-6	1-2	2-3	Assumes 15 years or greater life time without replacement at GEO, with option for local repair of PV arrays; the PV here is for general platform power, not to drive the WPT system(s).

Table 4-4 Supporting Infrastructure - Preliminary Technology Assessment

TECHNOLOGY AREA	TRL (est.)	R&D3 (est.)	TNV (est.)	Working Notes on Technology Requirements
Low Cost Expendable Launch Vehicles – Type A: HLLV	5-6	1-2	1-2	Assumes Large Cargo HLLV type launch vehicle, with 50 ton class capability (@ < \$3,000 / kg)
Reusable Launch Vehicles – Type B: VTHL Rocket RLV	4-5	2-3	2-3	Assumes Large Shuttle-like launch vehicle, with HLLV capability at 100 ton or more capability (@ less than \$1,000/kg)
Reusable Launch Vehicles – Type C: HTHL Hybrid RLV	3-4	3-4	3-4	Assumes smaller HRST type launch vehicle, with 25 tons class capability to LEO, with very low cost launch (@ less than \$500/kg)
Affordable In-Space Transport – Type A: Reusable High Thrust AIST Vehicle	4-5	2-3	1-2	Assumes Large launch vehicle, with payloads to GEO capability at 100 ton or more capability (@ less than \$2,000/kg)
Affordable In-Space Transport – Type B: Reusable Low Thrust AIST Vehicle	3-4	3-4	3-4	Assumes smaller HRST type launch vehicle, with 100 tons class capability to GEO, with very low cost (@ less than \$1,000/kg)
In-Space Refueling Capability	3-4	2-3	4-5	Assumes hybrid in-space refueling capability (for either SEPS propellants or cryogenic propellants) with long duration storage and transfer in microgravity
In-Space Assembly and Construction Systems (Stand-Alone Platform)	3-4	2-3	1-2	Assumes a very large-scale / integrated ISAAC system for assembly of SPS Type I (not self-assembling); assessment depends on details of the SPS concepts infrastructure requirements

CHAPTER 5**SPS POLICY AND OTHER CONSIDERATIONS**

This chapter discusses various important policy and related considerations for space solar power technologies in general, and for SPS in particular, including highly focused issues, such as spectrum allocation, and broader issues concerning the international and national legal and regulatory environment for SSP development. This chapter also summarizes a number of potential benefits of SSP technology R&D, and resulting SPS development, including benefits such as novel space system applications.

5.1 General Policy, Legal and Regulatory Considerations

Realizing SPS will involve a broad range of general policy and regulatory considerations – not to mention the detailed considerations of specific policymakers and the politics of key countries.^{xxxiii} For example, some of the national and international policy considerations that must be taken into consideration include: (1) space policies; (2) energy policies; (3) environmental policies; (4) technology research and development policies; (5) tax and/or incentive policies (vis-à-vis space development or energy); (6) defense and security policies; and (7) various factors related to the regulatory environment.^{xxxiv}

At a minimum, achieving space solar power will involve the international cooperation and coordination that will be necessary to realize the orderly, economic and efficient construction and subsequent operation of a solar power satellite. This goal will most likely only be achieved only through the establishment of appropriate international regulatory ground rules, plans and regulations. Such an international “regime” for SPS will require the acceptance by a group of countries to institute. In addition, individual countries frequently formulate policies, regulations and programs that are intended to restrain and/or promote selected technology R&D activities, particularly those related to national security, targeted industries, or the assurance of domestic competencies.

The following section briefly summarizes a number of examples of both international and national policy and legal considerations that will affect the progress of space solar power.

Selected Examples

National and international policies, agreements, programs are established to advance the objectives of the countries involved, while commercial firms – although they may be players both nationally and internationally – are typically driven by the financial interests of their owners and/or stockholders. Both existing and potential new policies, agreements and programs will establish the international environment within which governments, commercial firms, and other players will pursue space solar power technology R&D, and later SPS systems development.

Specific international regimes are typically created through treaties between nations, or among multiple countries for common purposes under which the participating states agree to abide by the agreed-upon rules. For obvious reasons, during the past 60 years space-related matters have been of particular international importance. “Space” has been pursued in the context of an international space regime created in large measure through the UN sponsored international space treaties and some other agreements. And, future SPS systems must operate within this existing regime, as it may be modified by future agreements and regulations. Some of the most SSP-relevant elements of the existing international regime for space activities (i.e., current international treaties, including the Outer Space Treaty of 1967^{xxxv}) include the following:

- All space activities must be carried out for the benefit and in the interests of all Countries and shall be the province of all mankind.
 - *SSP Impact:* SSP development and SPS system operations must benefit all countries)
- Space is free for exploration and use by all Countries, without discrimination of any kind.
 - *SSP Impact:* SSP development and SPS operations cannot restrict access to space for other space-faring countries...
- A Country must not appropriate space by any means.²³
 - *SSP Impact:* The capture of solar energy in space would not be considered as “appropriation”. However, the long-term placement of SPS in GEO slots might very well be considered as a *de facto* appropriation.

²³ For purposes of international agreements and regulations, a “Country” includes the companies and universities that are organized within that country.

- A Country must carry out space activities in the interest of maintaining international peace and security and promoting international co-operation and understanding (i.e., conflicts must be avoided).
 - *SSP Impact:* The capture of solar energy in space would not be considered as “appropriation”. However, the long-term placement of SPS in GEO slots might very well be considered as a *de facto* appropriation.
- Countries are prohibited from placing in space nuclear weapons or other weapons of mass destruction.
 - *SSP Impact:* Future SPS systems must be developed so as to be incapable of being “weaponized”.
- Countries bear international responsibility for space activities of their public entities and private companies.
 - *SSP Impact:* Commercial space firms pursuing SSP activities will be required to secure appropriate licenses from their respective governments.
- Countries are internationally liable for damage caused by the space objects of its public entities or private companies to a foreign state or to its persons.²⁴
 - *SSP Impact:* Future SSP technology R&D and later SPS deployment and operations must be pursued with careful consideration of liability issues (which will defer depending on whether possible damages are on Earth or in space).
- Each Country (including private companies within the Country) must (a) carry out space activities with due regard to the corresponding interests of all other Countries, and (b) avoid harmful contamination of outer space and celestial bodies and also adverse changes in the environment of the Earth.
 - *SSP Impact:* Future SSP technology R&D and later SPS deployment and operations must be planned in accordance with this principal. This will have particular relevance to issues associated with space debris, possible out-gassing from systems in GEO, etc.

²⁴ The reference is to “absolute liability” if damage is caused on Earth or to flying aircraft, or to “faulty liability” if the damage is caused in outer space.

In addition, there are a number of other important elements of the international legal regime within which SSP development would occur; these include:

- International Telecommunications Union (ITU). The constitution and regulations of the ITU apply to radio frequencies for non-communication purposes.
- Additional Notes: Access to & use of RF and GEO are available on a ‘first-come, first-served’ basis; later users must coordinate with earlier users, however earlier users are under no obligation to accommodate late arrivals.
 - *SSP Impact*: SSP R&D efforts and SPS operations must be coordinated through, and registered with the ITU. It may be necessary / possible for any specific frequency selected for a future solar power satellite (e.g., 2.45000 GHz) to be made exclusive. Also, there is a clear need for technical standards to avoid harmful interference and adverse impact on humans or the natural environment. (See the more detailed discussion in Section 5.3 below.)
- International Civil Aviation Organization (ICAO). The ICAO, based in Canada was established in 1944 by 52 nations in order to assure the safe, orderly and economic development of international air transport. The ICAO convention and ICAO-developed regulations provide the overarching guidelines within which all aircraft must operate.
 - *SSP Impact*: ICAO provides another framework for SSP R&D and SPS deployment/maintenance. There will be an exponential increase in traffic to and/or from space for the launch, construction and operation of SPS. It will be important to assure orderly and safe space and air traffic related to SSP. ICAO could be mandated for aerospace traffic management rules & safety standards.
- Space Debris Mitigation Guidelines. Although they are non-binding, the international space debris mitigation guidelines of 2007 provide generally recognized rules for current and future space operations.
 - *SSP Impact*: SSP / SPS efforts will need to take into account the Space Debris guidelines, including considerations of

debris mitigation and the expected debris environment within which an SPS would operate.

And, of course there are focused, national legal regimes that will frame or otherwise constrain the types of international activities that can be undertaken in pursuing space solar power; these include:

- Government International Trade in Armaments Regulations (ITAR).
The US and other countries impose legal restrictions on the sale or transfer of technologies that are related to military capabilities – including space technologies..
 - *SSP Impact:* Depending on the details of technological choices and international agreements, these restrictions will likely pose significant barriers to the free transfer of technology among government and commercial participants in SSP / SPS technology R&D and system development.
- Industrial Policies and Technology Transfer Restrictions. Finally, a number of countries pursue national policies with respect to specific industries, including the imposition of international technology transfer restrictions. These countries may also formulate specific programs and incentives intended to foster national capabilities in technologies of strategic interest to the particular country; these can include targeted technology investments, restrictions on eligibility for government contracts, tax and related incentives for investments, and other means.
 - *SSP Impact:* Depending on the details of technological choices and international agreements, these restrictions will likely pose significant barriers to the free transfer of technology among government and commercial participants in SSP / SPS technology R&D and system development.

Findings Concerning Legal / Policy Considerations

SSP technology development and SPS deployment and operations would need to be pursued in the context of a tremendous range of national and international policy and regulatory considerations. These international and national policies and regulations do not appear to inhibit the future development of SSP; however, they must be carefully examined to assure compliance wherever possible. (See examples and potential impact statements above.) And, it is possible that some new international legal

structures – for example, like the ISS Space Station Treaty – may be needed for specific programs and projects.

5.2 Specific SSP / SPS Policy Considerations

There are a number of important and highly specific policy issues that must be resolved in pursuing SSP/SPS development, deployment and/or operations, some of which are generic across all markets and others that depend upon the specific market to be addressed. The most important of these policy considerations include:

- Would solar power satellites be a “Green Energy” option;
- What are Key WPT Beam health and safety considerations;
- WPT beam spectrum allocation and management;
- Possible Space debris Impacts and Related Considerations;
- Potential WPT “Weaponization” Concerns; and,
- Strategies for International Coordination of SSP Development and Operations.

The following sections discuss briefly each of these, providing a preliminary assessment of whether the policy issue involved represents a fundamental “show-stopper” that would prevent SPS development even if other technical and economic issues can be resolved.

Solar Power Satellites As a “Green Energy” Option

Policy Issue Introduction. Even given that SPS are technically feasible, and even if they can provide energy at an economically competitive price, the question remains: would space solar power system options be “green”? In other words, would SPS contribute to addressing the need to reduce and/or mitigate the current risk of climate change? Several factors must be examined to resolve this question: the energy cost of manufacturing SPS, the energy cost of deploying SPS, the environmental impact of deploying and operating SPS, etc. In addition, space solar power options should be competitive with similar ground solar power options in terms of “greenness”, if they are to be of interest in pursuing so-called “green energy” policy options.

Policy Issue Analysis and Discussion. A key figure of merit for sustainable energy systems is how quickly the energy required to fabricate and deploy the system can be generated by the system after it begins

operations; this is known as the “energy payback time”. Ground-based solar power PV systems that are not required to provide stand-alone baseload power can achieve energy payback in 1-5 years for all types of solar arrays, including various cell technologies and system deployment schemes (ranging from building integrated PV (BIPV) to large-scale centralized PV-based power plants). A major driver of this payback time is the physical location of the PV power plant with desert locations (e.g., the Southwestern US) providing much faster payback than northern latitudes. Moreover, in 2002 it was the conclusion that BIPV deployments are the most energy-effective. xxxvi

The payback time ranges from about one (1) year for BIPV installations in high sun areas made from high efficiency c-Si to as much as five (5) years for low efficiency a-Si in a centralized power plant located in a poor sun area. Figure 5-1 presents the results of a high-level calculation of the energy payback time for various ground PV scenarios, including locations with high-, medium- and low- sun, and for both centralized power plant and building-integrated PV.

Figure 5-1 Energy Payback – Various Ground PV Cases xxxvii

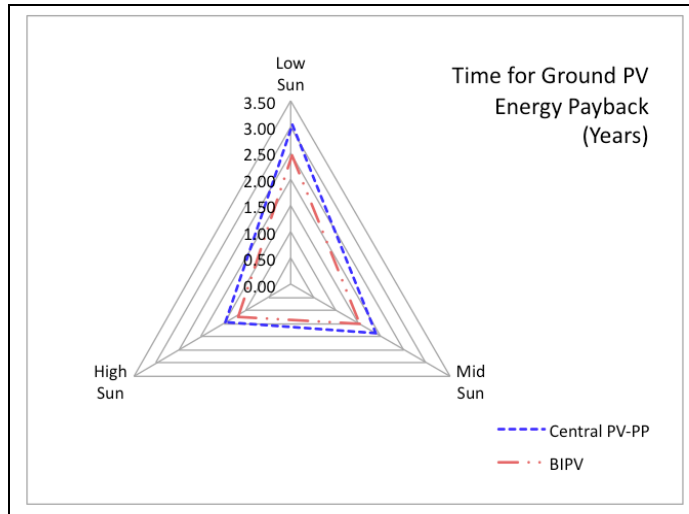

It appears that typical times for ground PV payback for large PV solar power plants are in the range of 1-3 years. For ground solar power, in all cases BIPV has been found to have a faster energy payback time than centralized PV power plants.

By comparison, recent studies comparing ground solar power and space solar power (per 2002-2004 ESA SPS studies) suggest that large-scale space solar or ground solar power plants might achieve energy payback in one year or less (although this estimate is highly dependent on various assumptions).^{xxxviii} Any differences were within the error limits of the analysis.

As was done in the case of the recent ESA studies, in future systems analysis involving commercial “baseload power”, distinctions among space solar power and other energy options must be carefully considered, including consideration of any needed over sizing of renewable energy supplies, and the addition of energy storage systems.

If the SPS concept can be developed successfully, solar power satellites would provide an extremely “green” sustainable energy alternative for the future. A preliminary analysis was performed to determine the expected heating that might be expected due to a solar power satellite beaming energy to Earth that would otherwise have passed without inception in nearby space.²⁵ From this analysis, it appears that a single SPS that delivered power of about 1.5 GW would add less than 0.000001 °C to Earth’s average temperature. Similarly, it appears that several thousand SPS with a total delivered power of about 15,000 GW (equivalent to the total global consumption of power circa 2005-2010) would result in less than 0.006 °C increase to Earth’s temperature – an extremely tiny amount compared to the aggregate thermal effects of similar power production from fossil fuels.

Figure 5-2 presents the results of this high-level calculation of the total increase in the Earth’s temperature that might be expected to result from the use of SPS to deliver a substantial share of the energy needed to drive civilization – currently about 15,000 GW.

It seems evident that by this first-order calculation at least, the heating effect of many more SPS (above the current total world energy consumption) would still result in a quite small increase in Earth’s average temperature.

²⁵ This analysis used the Stephan-Boltzmann law relating energy emitted to temperature and assumed the Earth was in energy balance, with an estimated total solar flux intercepted by Earth of $1.746 * 10^{17}$ watts, a nominal average terrestrial temperature of 15° Celsius and an estimated average emissivity for Earth of 0.8875.

Figure 5-2 Calculated SPS Contribution to Earth's Temperature

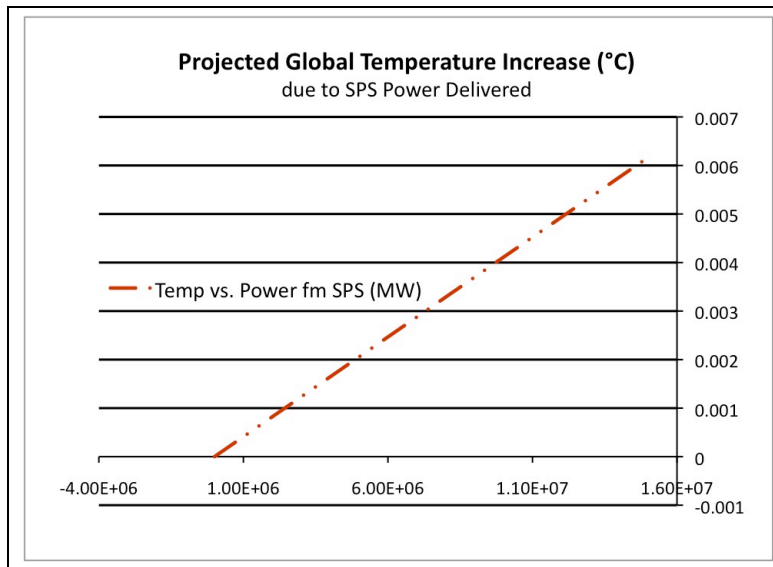

Image Courtesy Artemis Innovation Management Solutions

Summary Observations: Is SPS a “Green Energy” Solution? More detailed studies are needed, including integrated input-output matrix studies in order to better understand the true energy investments needed for SPS, and the resulting energy payback times that are required for these systems. However, at a high-level it appears that SPS could be a highly “green” option, with minimal energy cost for SPS space transportation, good energy payback times compared to centralized ground PV solar power plants, and extremely small contributions to increasing Earth’s temperature.

Beam Health and Safety Considerations

Policy Issue Summary. The single most important policy consideration for SPS is that of WPT beam health and safety. The issue involves several elements. First, there is the basic question of the safety and/or potential health effects of the WPT beam when operating as designed. Second, there is the question of whether the WPT transmission is “fail-safe” in the event of an unintentional operational mishap (i.e., an accident). The central issues involving WPT transmission health and safety involve (a) short-term illumination of humans and other fauna by the beam; (b) long-term illumination of flora or fauna by the WPT beam; and (c)

transient illumination of machines / electronics by the beam. Of these, the first consideration also includes the potential risk to eye safety for humans and other fauna.

Finally, there is the issue of whether the WPT system can be subverted from its intended energy delivery purpose to become a weapon. This latter issue – in other words, “weaponization” – is discussed at greater length as a special topic in Section 5.2.5 below.

Assessment of Impact(s). The most significant impact on SPS systems trades and technology selection of beam health and safety considerations is on SPS Type II, the near-visible laser WPT satellite. In order to assure beam safety, the ground rule for the IAA study is that the maximum allowable energy intensity must be less than the intensity of full summer sunlight at the equator (i.e., less than 1,000 watts per m²).

Recommended Action(s). It is recommended that as studies and technology R&D go forward that are directed toward SPS, WPT and related applications, there should be supporting research concerning WPT health and safety. (The discussion in Chapter 4 regarding beam pointing – particularly fine pointing – is closely related to these issues.)

WPT Beam Spectrum Allocation and Management

Policy Issue Summary. The issues of spectrum allocation and management for an SPS system are an important policy consideration. These issues fall into three broad categories: (a) WPT Transmitter spectrum management; (b) WPT Receiver Emissions (including Harmonics); and (c) SPS Operational RF Emissions.

WPT Transmitter Spectrum Management. The primary challenge in spectrum management for SPS WPT is that of the extremely high power emissions of the transmitter in space. Clearly, whatever portion of the electromagnetic (EM) spectrum to be employed by and SPS must be set-aside from other communications or operational applications.

WPT Receiver Emissions (including Harmonics). There are two principal types of expected RF emissions from an SPS using microwave WPT; these are (1) the pilot signal (for a retro-directive system), and (2) re-emitted harmonics from the incoming power beam. Most WPT planning has centered around ISM RF bands – narrow segments of the electromagnetic (EM) spectrum set-aside by international regulatory agreement for use in Industrial, Scientific and Medical (ISM) applications.

SPS Operational RF Emissions. Finally, the ongoing operations of an SPS platform –each of which will be a huge complex of constantly communicating systems – could represent a significant source of RF energy. For example, an SPS of 10,000 modules, each communicating at a power output of from 10-100 watts, would radiate at a total of about 1 MW (50—times more than the most powerful GEO communications satellite in operation in 2008-2010).

Assessment of Impact(s). Spectrum management is a significant issue for future SPS R&D and deployment; it should be tractable, however, depending on early and ongoing coordination through existing national and international organizations (such as the International Telecommunications Unit (ITU)).

Recommended Action(s). Future R&D activities should formally incorporate a funding consideration of spectrum management issues, including working through various appropriate national and international organizations to assure that knowledge of the potential WPT application and results of studies are well-understood.

Space Debris Considerations

Policy Issue Summary. An issue that has increased dramatically in importance since the 1970s is that of space debris. The principal regime in which orbital debris is found is that of LEO – due largely to ETO transportation-derived fragments. There are three aspects to this issue for SPS. The first issue is the potential impact of LEO debris on dedicated SPS infrastructure. The second issue is the potential production of LEO debris by SPS ETO and in-space transportation. Finally, the third issue is the potential interaction of GEO SPS in-space transportation with LEO debris.

Potential Impact of LEO Debris on SPS Infrastructure. The existing significant space debris environment in low Earth orbit (LEO) places significant operational constraints on concepts and operations for future SPS infrastructures. In particular, it is evident that SPS systems can spend only a limited period of time in LEO before being transported beyond to higher, safer orbits.

Potential Production of LEO Debris by SPS Transportation. At the same time SPS transportation to space and operations in LEO are at some risk due to LEO space debris, it is also critical that the R&D to development SPS

systems concepts and supporting ETO and in-space transportation must consider carefully the possible production of additional debris in LEO. Given the immense scale of SPS operations, it is evident that SPS systems and infrastructures must be designed and developed to minimize the production of space debris under normal circumstances, and to be “fail-safe” vis-à-vis space debris in the event of a mishap.

Interaction of the GEO SPS and Space Debris. The risk due to space debris is significantly less in GEO than it is in LEO. However, as in the case of LEO given the immense scale of SPS operations in GEO, it is evident that SPS systems and infrastructures must be designed and developed to minimize the production of space debris under normal circumstances, and to be “fail-safe” vis-à-vis space debris in the event of a mishap. In this light, the standard practice of removing a failed GEO satellite by simply boosting it slightly outside of that orbit is clearly unacceptable. SPS in GEO must be developed to incorporate proactive containment and essentially permanent disposition of any failed system elements.

Assessment of Impact(s). The overall impact of this policy / technical issue on SPS concept options should be readily managed. The greater the degree of modularity in the SPS concept, the less vulnerable the overall SPS platform will be to an ill-timed space debris impact; contrary-wise, the greater the degree to which the SPS platform is monolithic and its elements unique during transportation, then the greater the degree of vulnerability of the platform concept to space debris.

Recommended Action(s). Future SSP / SPS systems analysis studies should incorporate explicitly the challenges of space debris, including that related to LEO, GEO and SPS-supporting in-space transportation and infrastructures. The objectives of these studies should include (a) minimizing the vulnerability of SPS systems during ETO, LEO transit and in-space transportation and operations; and (b) assuring fail-safe operations vis-à-vis the risk of space debris production. These studies should examine various cases, including worst-case scenarios regarding space debris.

Potential Weaponization Concerns

Policy Issue Summary. The principal issue related to potential weaponization is related to the wireless power transmission system of the SPS. In the 1970s, there was little or no issue associated with the weaponization of SPS platforms for several reasons. For example, the 1979

SPS Reference System involved a low intensity microwave power transmission system. Moreover, the beam was incapable of being rapidly redirected due to the use of a huge mechanical gimbaling system for large angle point. And, all of the systems in the ERDA-NASA studies of the late 1970s were to be positioned over the equator at the longitude of the US.

However, the SPS concepts under consideration in the IAA study (particularly Type II and Type III) might be rapidly redirected. Also, global energy markets are being examined in the present study, and there is the possibility that higher beam intensities could be considered (particularly for SPS Type II). As a result, potential weaponization is a legitimate policy issue. There are two potential weaponization issues: (a) those concerning terrestrial targets and (b) those concerning targets in space. The following discussion treats these issues in turn.

Terrestrial Issues. A key issue vis-à-vis the potential weaponization of a future SPS with respect to objects on Earth involves the temperature of objects on the Earth that are illuminated by the WPT transmission. In particular, the concern is associated with the possible use of the SPS transmission to ignite targets on Earth. The analysis incorporated four ideas:^{xxxix, 26}

- (1) The maximum temperature of an illuminated surface will reflect equilibrium between the energy input to the surface and the energy output from the surface (for passively cooled objects);
- (2) the key component of energy input is radiant energy incident on a surface as a blackbody (this is a simplifying assumption);
- (3) the output energy from a surface will be approximately the sum of the convective cooling of the surface and the radiant energy from the surface as a blackbody (this is a second simplifying assumption); and,
- (4) the upper temperature limit allowable is that at which an illuminated wood, paper or a similar surface material would ignite.

Figure 5-3 presents graphically the results of this preliminary analysis. The principal observation of the analysis is that at night (i.e., with no incident sunlight), the allowable incident WPT intensity at Earth is not more than approximately $6,000 \text{ W/m}^2$ – corresponding to a temperature of

²⁶ A number of considerations have been dropped from this analysis for the sake of simplicity; for example, the fact that energy is radiated from all surfaces of an object, not just the surface illuminated by the WPT beam. A more detailed analysis is needed.

about 505 Kelvin (i.e., 451 °F – the standard combustion point of paper and/or wood). During the daytime, the solar flux must be added to the WPT beam, and the total should be less than this upper limit for incident intensity; for local noon during the summer, the upper limit appears to clearly be about 5,000 W/m² (which again corresponds to the combustion point of paper / wood).

Figure 5-3 Wireless Power Intensity at Ground and Induced Temperatures

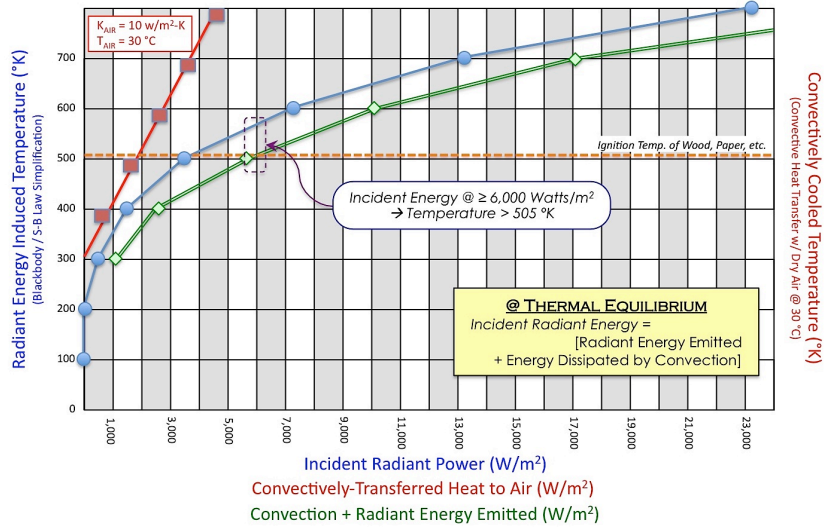

Credit: Artemis Innovation Management Solutions LLC

In-Space Issues. In addition to the risk of weaponization with regard to terrestrial targets of interest, there is the additional issue of possible in-space objects. In this case, there are a wide range of issues, including possible illumination and damage to sensors systems, possible damage to on-board power systems, and potential to induce damaging charging and electrostatic discharges. These issues are highly sensitive to the choice of either RF and laser WPT, as well as the specific power levels. In general, however, the key capability will involve rapid, precision and independent pointing of WPT transmissions.

Assessment of Impact(s). The above preliminary analysis examines the possible risks of weaponization for either terrestrial or in-space targets. In the case of the former, physics of heat transfer vis-à-vis objects on Earth

that might be illuminated by a WPT transmission, sets a clear upper limit for the peak energy intensity that an SPS WPT system should be allowed to deliver to Earth. However, there is the additional issue of how easy (or difficult) it will be for multiple SPS to combine their transmissions on a single target.

For the sake of assured safety in SPS/WPT operations, it seems clear that both additional R&D and specific system design steps will be needed.

Recommended Action(s). In order to assure that the risk of weaponization is minimized, it seems clear that the peak power intensity delivered by a single SPS WPT transmission must be substantially less than the intensity at which ignition of common materials could be caused. In addition, no easy combination of SPS WPT transmission should be sufficient to exceed safe limits vis-à-vis combustion.

In the case of microwave WPT, an upper limit of about 200-250 watts per m² was assumed in studies of the 1970s. A similar upper limit seems entirely appropriate for near visible laser WPT as well. This limit would assure that even in the case where the WPT transmissions from 18-20 SPS were simultaneously to be directed at the same location on Earth, the energy intensity limit would not be exceeded.²⁷

Strategies for International Coordination of, and Cooperation in SPS Development and Operations

Clearly, solar power satellites because of their inherent cross-national potential will entail consideration international coordination (as do communications satellites, global positioning services, orbital debris monitoring and mitigation, etc.). Detailed recommendations as to the precise character and appropriate international organizational approaches to accomplish this coordination were not considered by the IAA study. However, one approach was discussed: the establishment of a formal international SPS working group. This group would operate in the context of a number of specific functional interfaces, as shown in Figure 5-4 below.²⁸

²⁷ Through the use of “fail-safe” design approaches (e.g., involving the pilot signal) with a retro-directive phased array WPT transmitter, it should be possible to provide even greater assurance that weaponization of SPS transmissions cannot occur.

²⁸ This figure is derived from one presented by Janet Verrill, President, Macro-Projects International at the SPS 2009 International Symposium in Toronto, Canada.

The central concept is the creation of an “SPS International Coordination Working Group” (SPS-ICWG) that would provide both an ongoing point of contact and an overview of space solar power and emerging solar power satellite projects. Membership of the SPS-ICWG would comprise of representatives from the space programs of various nations, key industry players, key academicians, etc. The chair of the working group would be a rotating position, which might be held by various member countries in turn.

Figure 5-4 A Notional Architecture International SPS Coordination

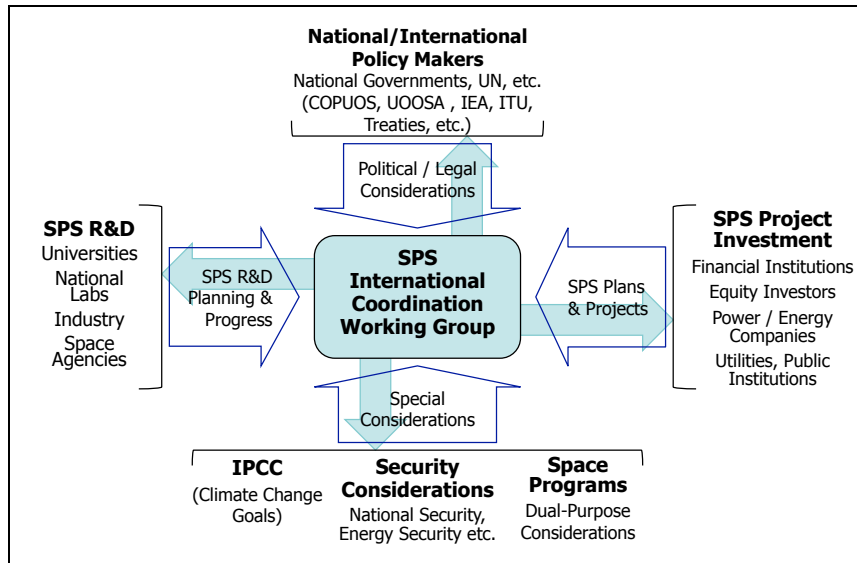

The SPS-ICWG could play a number of key roles, analogous to the role played by international science organizations, such as the Mars Exploration Working Group (MEWG) or the International Lunar Exploration Working Group (ILEWG), or by coordinating academic institutions. For example, the Working Group could review and assess new technology developments from the scientific community on one hand, and programs /investments on the other hand.

There are a number alternative means by which the SPS-ICWG could be organized. For example, it might be formulated in the context of the IAA, under the auspices of UN, or through an agreement among participation countries (such as is the case with the ILEWG). In any event,

the purpose of the Working Group would be to facilitate and to accelerated the development of key SSP technologies, and the implementation of SPS.

In addition, international relationships will be vital in developing SSP technologies and systems. Collaboration engaging various countries, companies and government agencies, and involving non-governmental organizations (NGOs) will be essential to achieve SSP technology development goals. The promotion, and facilitation of the formation of effective partnerships will be key to realizing such collaboration. (This is one role that the SPS-ICWG could play.)

Clearly, participation in SSP R&D and SPS development would be a voluntary undertaking for various investors – including countries, financial institutions and corporations. Such investments would involve technology developments, pursuing specific SPS projects, etc. Similarly, returns from these investments (ranging from space applications of SSP systems, to power delivered from SPS to markets) would be entirely independent of any involvement of the Working Group. This is an area for additional study.

5.3 Other Considerations: Space Applications²⁹

Historically, space missions have always been “power paupers” – limited in design choices due to the minimal power availability and the high cost of that power. As a result, there are a wide variety of potential benefits that SSP technology and systems – and the R&D efforts leading to such – could establish for prospective future space applications.³⁰ The range of these space applications could include:

- Solar Electric Power and Propulsion Systems for Exploration, such as
 - High Energy Solar Electric Propulsion based Orbital Transfer Vehicles (OTVs) for Earth orbit operations;

²⁹ It must be noted that the charter of the IAA SSP Study Group was limited to space solar power; particularly in the case of possible space applications, no analysis to compare alternative sources – such as space nuclear power – was performed. The only question examined was that of space applications of SSP. A future study should consider the range of energy options using comparative analysis.

³⁰ The 2000 National Academy of Sciences Report on NASA’s roadmap for the advancement of SPS concluded that there is a range of prospective space applications of SSP technologies and systems concepts.

- Multi-megawatt (MMW) Solar Electric Propulsion Systems (SEPS) for Interplanetary Human Exploration Missions (such as Human Mars Missions, HMM); and,
- Advanced Solar Electric Propulsion Systems for robotic science and human exploration precursor missions.
- Solar Electric Power for Lunar and Planetary surface operations, such as
 - Power delivered from space to surface systems
 - Power delivered from one point on the surface to another (e.g., into permanently shadowed regions)
 - Power generated locally at locations, and for systems used at surface access and/or operations
- Solar Electric Power for Large Earth-orbiting Platforms, such as
 - Very large satellite applications in GEO, and/or high-power platform applications in LEO)
- Solar Electric Power and/or Propulsion for Outer Planet / Deep Space Missions, such as
 - SEP systems for missions traveling to the outer planets
 - Solar Power for deep space missions in the Inner Solar System, through the Main Belt Asteroids

In addition, for selected SPS system concepts there may also be special applications of the specific technologies and/or systems involved. For example, in the case of RF phased array WPT systems, there may be useful applications the large aperture systems technologies. Similarly, in the case laser WPT systems, there may be applications of the relevant technologies for deep space communications, space-based optics, etc.

Solar Electric Power and Propulsion Applications for Exploration Missions.^{x1} Solar Electric Propulsion Systems (SEPS) are one of the most significant potential space applications of the systems and technologies that are needed to enable SPS, and of the actual systems that would needed to deploy and operate SPS in GEO. These include applications that range from SEPS for orbital transfer vehicles (OTVs) for Earth orbit operations, to multi-megawatt (MMW) SEPS for interplanetary missions.

Energetics of Transportation in the Earth-Moon System and Beyond. As illustrated in Figure 5-4, there are a variety of possibilities and energy requirements for transportation in the Earth-Moon system and the inner

Solar System. There are several general observations that may be made regarding this highly generalized “energetics map”.

Figure 5-4 Space Transport Energy Requirements Diagram

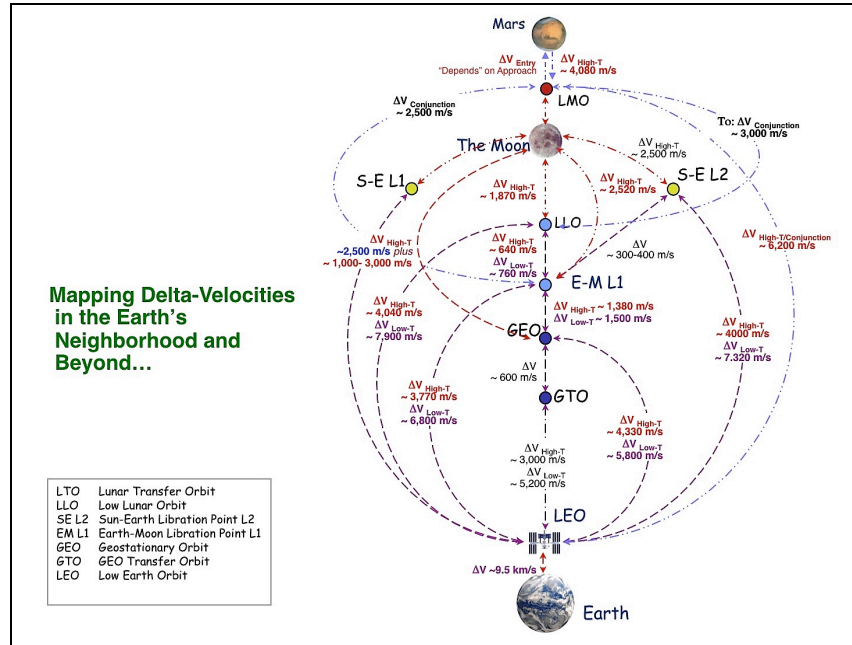

Credit: NASA / J. Mankins (c. 1999)

First, the energy requirements (measured in units of “meters per second” in the figure) change significantly depending on the technology: increased by roughly 70%-90% when the propulsion concept shifts from a high-thrust / short duration firing options (such as high-energy cryogenic propulsion) to low-thrust / long-firing options (such as SEPS). This is due to the increase in the gravity losses when a vehicle must take longer to move from one orbit to another in a gravity well.³¹

Second, it is interesting to observe that there is a close similarity among several of the propulsion cases illustrated in Figure 5-4. In particular, the

³¹ Of course, the total change in velocity is in the exponent of the rocket equation, and is multiplied by the Specific Impulse (i.e., the fuel efficiency of the propulsion system). Since the fuel efficiency increases much more than the total change in velocity required, low thrust systems are interesting for diverse applications.

energy requirements for low thrust transportation for several cases of interest are as follows:

- SEPS Transport from LEO to GEO Change in Velocity:
 - ~ 4,300 meters/second.
- SEPS Transport from LEO to Low Lunar Orbit (LLO) Change in Velocity:
 - ~ 4,000 meters/second.
- SEPS Transport from LEO to the Earth-Moon Libration Point L1 (E-M L1) Change in Velocity:
 - ~ 3,800 meters/second.
- SEPS Transport from LLO to Low Mars Orbit (LMO) Change in Velocity:
 - ~ 3,000 meters/second.
- SEPS Transport from E-M L1 to LMO Change in Velocity:
 - ~ 2,500 meters/second.

The central conclusion that may be drawn from these data is that the change in energy required for an SPS transportation system capable of moving equipment and logistics from LEO to GEO (about 4,300 m/s) is also more than capable of achieving all of the other missions listed. As a result, the SPS transport infrastructure could also represent the potential for a significant advance in future space capabilities of general value for human exploration beyond LEO. Some additional aspects of these options are discussed in paragraphs that follow.

Human Mars Mission (HMM) Applications.^{xii} Human Mars Mission (HMM) applications of advanced solar electric propulsion can be conceptualized at three scales: (a) relatively low power (e.g., 50-100 kW) SEPS for application in precursor Mars Sample Return (MSR) missions as early precursors to HMM, (b) mid-power (e.g., 500 kW – 1,000 kW class) SEP freighters the pre-position logistics and systems for an HMM at Mars prior to the human crew being launched, or (c) high-power SEP (e.g., 5,000 kW – 10,000 kW class) SEP crew-carrying interplanetary vehicles.

Figure 5-5 presents two concepts for high-power solar electric propulsion (SEP) systems that could support both SSP transportation (LEO to GEO) and HMM applications (e.g., E-M L1 to LMO). (Both of the concepts illustrated are highly modular SEP vehicles that incorporate the design approaches discussed elsewhere in this report. Alternative, more

monolithic vehicle architectures are more typically considered and have been examined more extensively. However, if feasible, then modular approaches should be capable of realizing much more affordable solutions.)

Figure 5-5 Examples of Large SEPS Applications (SSP and HMM)

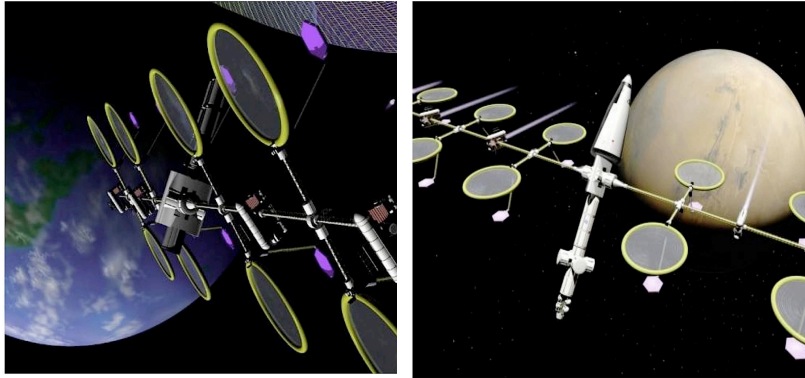

Credit: NASA Artwork; by SAIC/Pat Rawlings

Power for Lunar and Planetary Surface Operations. These prospective applications include (a) power delivered from space to surface systems; (b) power delivered from one point on the surface to another (e.g., into permanently shadowed regions); and (c) power generated locally at locations, and for systems used at surface access and/or operations. Recent wireless power transmission technology R&D has addressed at a low TRL this prospective application. For example, there have been a number of recent demonstrations of WPT to moving targets (i.e., simple rovers) that have validated at very short range this concept.^{xliii}

Power for Outer Planet / Deep Space Robotic Missions. For outer planet operations, the solar intensity is too faint to conveniently allow solar energy to be used for spacecraft beyond the orbit of Jupiter. However, at Earth orbit and throughout the inner Solar System, SSP technologies might very effectively be used to deliver high capacity, high power SEP transportation to the outer planets and other deep space robotic missions. As indicated above, advanced SSP technology SEP stages will be more than capable of sending robots at high speeds to deep space. In such cases, power at the destination would likely be provided by RTGs, DIPS, or small space reactor power systems.

5.4 Other Considerations: Terrestrial Benefits

A range of additional potential benefits could be derived from an ambitious, advanced technology effort such as space solar power. Some of these benefits could include advances in a wide range of useful technologies, including robotics, solid state electronics, modular software systems, advanced materials, and others. And, of course, the various transportation systems (ETO and in-space transport) would be broadly valuable for other applications (such as public space travel). Other benefits would comprise various opportunities for alternative terrestrial market applications of space solar power; these might include water desalination and purification in remote locations, and chemical processing such as synthetic fuel production and nitrogen fixation and fertilizer production for agriculture in the developing world.

Another important and clear terrestrial benefit that would result from the development and deployment of space solar power is that of substantial numbers of new, high-technology jobs in the research, demonstration, manufacturing, deployment and operations of SPS. Of course, such benefits will depend directly on the scope and scale of SPS implementation. Figure 5-6 illustrates one such SPS deployment scenario, as well as the jobs that could result during the first three decades of deployment and operations.³²

Figure 5-6 Potential Personnel Required for a Large-Scale SPS Case

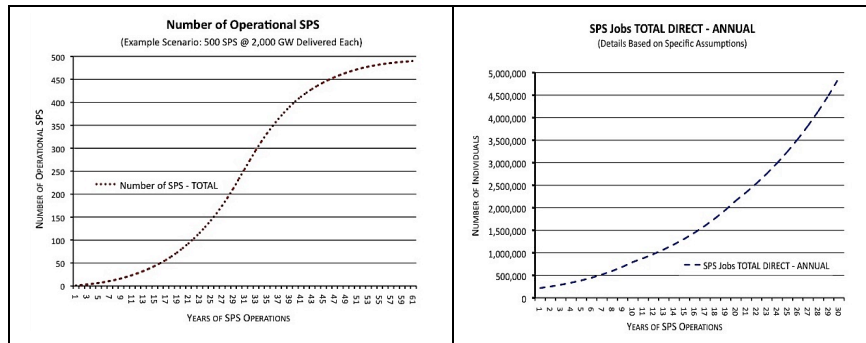

Credit: Artemis Innovation Management Solutions LLC

³² Key assumptions required for this projection included: (1) deployed cost of each SPS @ \$20 billion, split approximately evenly between hardware and deployment (plus a small percentage for receivers); (2) annual operations of 5% per year; (3) total cost contribution due to labor of labor costs ranging from \$50,000 to \$100,000 per person-year (depending on labor category).

As illustrated above, in the case of large-scale deployment involving roughly 500 SPS deployed (each generating some 2,000 MW), operated and maintained over a period of some 60 years (including regular repair and maintenance), annual employment on the order of 5,000,000 individuals might be realized eventually.

Please note: clearly, any projection of future personnel requirements is highly dependent on the assumptions involved. The key conclusion from this notional analysis is that the deployment of SPS on a scale large enough to make a meaningful contribution to global energy requirements over the coming century must perforce involve a large number of jobs – in engineering, in manufacturing, in space transportation and operations, etc.

5.5 Summary

There are a number of important policy considerations that must be taken into account in considering the future prospects for solar energy from space and related technology developments. The preceding Chapter has examined a number of these. General topics considered included (1) the overall international regime (e.g., the Outer Space Treaty) that will comprise the framework for space solar power development; (2) various international legal requirements (e.g., the ITU, and space debris mitigation guidelines) with which SPS must comply; and, (3) relevant national legislation and regulations (such as ITAR in the US and similar rules in other countries).

Detailed topics examined included (1) WPT beam health and safety considerations; (2) WPT spectrum allocation and management; (3) space debris considerations; and, (4) potential weaponization concerns. None of these factors appears to be insurmountable for SPS R&D eventual deployment. However, each of these (and others) will require appropriate attention during the early phases of SPS development.

It is clear that SSP R&D could yield significant benefits for a wide range of non-SPS applications – in space and on Earth. Some of these have been touched upon in the preceding chapter, particularly those related to space exploration, Earth orbiting satellites, and terrestrial applications of SSP technologies. In addition, SPS deployment would create numerous research, engineering and manufacturing jobs globally.

Chapter 6, which follows, turns to the broad issues of prospective SPS markets and economics.

CHAPTER 6**SPS MARKET ASSESSMENT AND ECONOMICS**

This chapter articulates a set of strategic scenarios for the future that frame potential SSP/SPS markets and economics. The chapter also reviews past studies of SSP economics and defines the framework for establishing figures of merit (FOMs).

From the 1960s through the 1990s, the principal markets discussed for SPS-delivered power were identified as large, but otherwise conventional baseload power markets. One of the most interesting developments in SSP/SPS economics during the past decade has been the emergence of what might be described as “premium niche markets” for space solar power. These markets for space solar power delivered energy are characterized by several factors, including:

- Market demand for power that is largely insensitive to the cost of the power provided. (For example, this might be the case if there are legislatively mandated “green energy” requirements that must be satisfied.)
- Geographically or otherwise isolated markets where there are few if any affordable competing sources of energy.
- Markets that are actually or potentially transient in character, and therefore do not justify investments in substantial fixed infrastructures (e.g., secure energy or power transmission systems to deliver alternative, lower cost energy).

An example of such a PNM would be a military forward basing application. These premium markets appear to be global in character and they are substantial in economic potential – but they offer prices that far exceed conventional, fossil fuel derived baseload power markets. Another promising development in SSP/SPS economics during the past decade has been the emergence of the policy goal of reducing CO₂ emissions, and concomitantly boosting the deployment of renewable energy systems (RES) – essentially incentives for the deployment of wind, solar or other low CO₂ emission power sources.

The starting point for this discussion, however, is the section that follows: it presents a quick review of past SPS market and economic studies, including both the objectives of these studies and the assumptions that framed them.

6.1 Past SPS Market & Economic Studies

During the 1970s, US SPS studies focused on technical design issues, and assumed a very top-down, national policy driven market scenario in which power from some 60 satellites would be delivered in 5,000 MW transmissions to 60 ground receiving sites in the US – for a total of some 300 GW total delivered power. The total cost of the deployed infrastructure and SPS was divided directly by the total power delivered over a number of decades to determine the cost of the power. Following 1980, international activities concerning SPS tended to focus on various technology objectives (including sounding rocket experiments, etc., discussed elsewhere).

Since the mid-1990s, the purpose of past SPS market and economic studies has been to establish market-driven economic objectives (e.g., specific price in terms of ¢/kW-hour) that could in turn be used to evaluate various technology and systems design options. During NASA's Fresh Look study of SSP, economic considerations were closely integrated into architecture-level systems analysis studies. The economic objective established for the Fresh Look study was a goal of some 10¢/kW-hour for baseload power.

The NASA approach changed by the late 1990s. During NASA's SSP Exploratory Research and Technology (SERT) program (1998-2001), an independent economic assessment of SSP was conducted.³³ Some of the key assumptions of that assessment were approximately as follows:

- The energy market to be served by SPS will be the US baseload power market (not including Hawaii and Alaska, or the US territories).
- The market price that must be achieved for SPS power to be sold would be that of the lowest power price (i.e., consistent with a power generation cost of approximately 5¢/kW-hour).

³³ This independent economic assessment was conducted for NASA by a Washington D.C.-based think tank, "Resources for the Future".

- The return on investment (ROI) for SPS investments must be approximately 30% or more (i.e., comparable to that of information technology (IT) companies of the late 1990s).
- There would be no explicit incentives for space solar power (i.e., no tax incentives, no loan guarantees, no policy-driven CO2 reduction objectives, etc.)
- The above assumptions would continue to be true for the foreseeable future (i.e., out to several decades from the 2000 timeframe).

Together, the above assumptions for the SERT program were consistent with the requirement that power delivered by SPS should be roughly equivalent to power delivered by coal-fired or natural gas turbine-based baseload electrical power plants.

The goal for the IAA study has been to frame an overall economic context for its assessment of space solar power – recognizing that the Academy study did not possess the resources to develop a fully rigorous economic forecast, nor to integrate economic objectives into a comprehensive end-to-end / architecture level systems analysis study. This assessment approach began with the definition of a set of four strategic global scenarios, described in the section that follows.

6.2 Framing the Question of SSP: Strategic Global Scenarios

In order to guide the framing of specific market cases and architectures for Solar Power Satellites, the International Academy of Astronautics (IAA) has formulated three high-level scenarios for the future of energy and the environment globally during the remainder of this century. The four energy and the environment scenarios being used in this IAA study may be characterized at the highest level by the following three titles: (1) “Business as Usual”; (2) “Fossil Fuels Run Out”; (3) “The Frog Gets Cooked; and, (4) “Green Policy Triumphs”. Figure 6-1 illustrates these scenarios.

All of these scenarios suppose that the current scientific consensus regarding greenhouse gas (GHG) emissions and global climate change is correct: namely, that human-caused increases in the atmospheric concentrations of GHG are responsible for observed changes in global climate over the past several decades.

Figure 6-1 Global Energy / Economic Scenarios for SSP

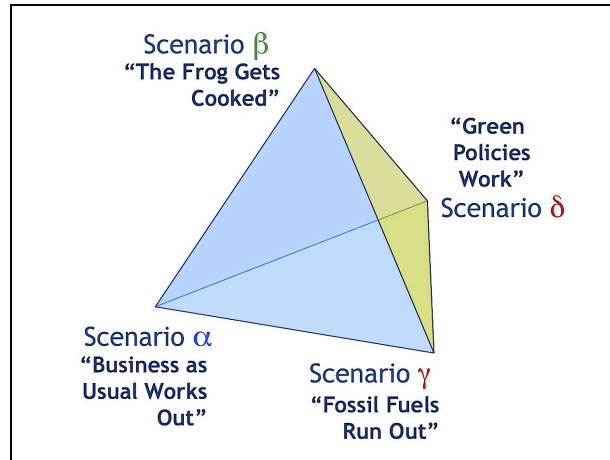

Credit: Artemis Innovation Management Solutions

The key questions that these Scenarios explore are: (1) how extensive are Earth's reserves of fossil fuels? And (2) what do governments do in response to concerns about rising GHG concentrations and the looming risk of climate change?

The following paragraphs provide additional details regarding each of the four global scenarios.

"Business as Usual Works Out" (Scenario Alpha)

This scenario, as its name suggests, assumes simply that there is no significant change from current (2008-2010) policies regarding climate change or energy utilization / research and development. Hence, modest efforts continue in both the control of greenhouse gas (GHG) emissions and the development of novel new energy technologies. Moreover, the scenario presupposes that the current levels of fossil fuel use (along with projected increases due to population growth) continue – resulting in market-driven price increases, but no sudden shortages. Fossil fuels will peak, but later than in more pessimistic cases.³⁴

³⁴ As noted elsewhere in this report, the International Energy Agency (IEA) announced in November 2010, while this report was in final edits that "peak oil" had in fact occurred circa 2006. This implies that the "Business as Usual" case is invalid as a baseline. This consideration should be examined in greater detail in future assessments.

Key aspects of this scenario include the following:

- Moderate investments (consistent 2008-2010 global advanced energy R&D funding levels) are made during the coming decade in new, more-sustainable Energy Technologies.
- There are significant increases in the net price of fossil fuel-based energy that occur due to market forces, primarily later in the century.
- There are continuing increases in GHG, but these are moderated by current policies and technology substitution, and climate change through the end of the century is at the lower end of projections.
- There are stable, slowly increasing prices for conventional energy due to international competition for resources.
- There are continuing policy-driven regulatory changes at modest levels, including somewhat improved mileage standards, some legislative requirements for increasing percentages of carbon-neutral energy, etc.
- Increases in the net price of fossil fuel-based energy occur due to market forces, but these occur entirely later in the Century.
- Peak global production of fossil fuels occurs as follows:
 - Petroleum → peaks in 2010-2015
 - Natural Gas → peaks in 2060-2080
 - Coal → peaks circa 2100
- Electrical Power Generation (early in the Century):
 - Primary Commercial Baseload Electrical Power @ about the same as 2010 (e.g., approximately 5¢-10¢/kilowatt-hour)
 - Remote / Leveraged Commercial Baseload Electrical Power @ about the same as 2010 (e.g., 25¢-50¢/kilowatt-hour)
 - Premium Niche Market Electrical Power @ about the same as 2010 (e.g., \$2.00-\$2.50 /kilowatt-hour or more)
- Electrical Power Generation (late in the Century):
 - Primary Commercial Baseload Electrical Power @ higher than 2010 (e.g., approximately 10¢-20¢/kilowatt-hour)
 - Remote / Leveraged Commercial Baseload Electrical Power @ higher than 2010 (e.g., 50¢-\$1.00/kilowatt-hour)
 - Premium Niche Market Electrical Power @ higher than 2010 (e.g., \$4.00-\$5.00 /kilowatt-hour)

“The Frog Gets Cooked” (Scenario Beta)

This Scenario postulates that there is a dramatic change from the current (2008-2010) national and international policies to develop new, more sustainable energy sources while increasing the efficiency with which we use all energy sources. Instead of that course, this scenario supposes that (1) energy technology and conservation policies are overturned and (2) that principal fossil fuels – in particular coal – do NOT start to run out starting around mid-century. In this case, huge numbers of additional coal-fired power plants are constructed and continue to operate until well into this Century – dramatically increasing atmospheric levels of GHG. There are modest to minimal advances in technology that are driven by the goal of reducing Green House Gas (GHG) emissions, but these occur only slowly. During the first half of the Century, there are significant increases in GHG, and depletion of fossil fuels only begins to occur late in the Century. Scenario 3 anticipates that significant increases in GHG emissions, and that the worst-case projected temperature increases will occur as a result.

Because of these developments, in this Scenario there are significant global climate change impacts due to accelerating GHG accumulations. In addition, because of these increases in GHG, and resulting climate change, there is meaningful destabilization in global economies and international relations. International competition for fossil fuels becomes fierce, and sea levels rise – resulting in rising geopolitical tensions, occasional conflicts and increasing energy prices. Key aspects of this scenario include:

- Minimal investments are made during the coming decade in new, more-sustainable Energy Technologies.
- There are stable, but steadily increasing prices for conventional energy due to international competition for resources.
- Significant increases in the net price of fossil fuel-based energy occur due to market forces, primarily later in the Century.
- There are enormous increases in GHG and resulting global climate change through the end of the century is beyond the high end of current projections.
- Peak global production of Fossil Fuels occurs as follows:
 - Petroleum → peaks in 2020-2030
 - Natural Gas → peaks in 2080-2100

- Coal → peaks post 2100
- Electrical Power Generation (early in the Century):
 - Primary Commercial Baseload Electrical Power @ roughly the same as 2010 (e.g., approximately 5¢-10¢/kilowatt-hour)
 - Remote / Leveraged Commercial Baseload Electrical Power @ roughly the same as 2010 (e.g., approximately 25¢-50¢/kilowatt-hour)
 - Premium Niche Market Electrical Power @ at roughly the same as in 2010 (e.g., approximately \$2.00-\$2.50 /kilowatt-hour)
- Electrical Power Generation (late in the Century):
 - Primary Commercial Baseload Electrical Power @ much higher than in 2010 (e.g., about 15¢-30¢/kilowatt-hour)
 - Remote / Leveraged Commercial Baseload Electrical Power @ higher than 2010 (e.g., approximately 75¢-\$1.50/kilowatt-hour)
 - Premium Niche Market Electrical Power @ much more than 2010 (e.g., roughly \$6.00-\$8.00 /kilowatt-hour)

“Fossil Fuels Run Out” (Scenario Gamma)

This Scenario postulates the failure of current national and international policies to develop new, more sustainable energy sources while increasing the efficiency with which we use all energy sources. Instead, this Scenario accepts that the issues are real, but supposes that efforts started in 2008-2010 will bear fruit too late. Some advances will occur of course, and these will have some modest impact on the goal of reducing GHG emissions, but the reductions in fossil fuel use will not keep up with dramatic growth in ongoing fossil fuel consumption (e.g., projecting forward from the rates of growth observed in 1990-2010). Most important: this scenario supposes that the Hubbert Curve and related projections are correct and that there will be upper limits to the maximum annual production of key fossil fuels.

As a result, in this Scenario the significant depletion of all fossil fuels occurs during this Century. This Scenario – “the Fossil Fuels Run Out – anticipates that GHG emissions will continue to grow rapidly until mid-Century, and that they will begin to decline only once fossil fuels are

deplete. However, as fossil fuels peak, (and the markets clearly see that peaking will occur), then market prices for energy go up and stay up.

Because of these future events, in this Scenario it is postulated that there are major global climate change impacts due to past GHG accumulations and there are drastic increases in energy prices, but not until later in the Century.

Key aspects of this scenario include:

- There are some investments in new, more-sustainable Energy Technologies, but these R&D investments are only partially successful.
- There are selected policy-driven regulatory changes, including modest mileage standards, some legislative requirements for increasing percentages of carbon-neutral energy, etc.
- After the first several decades, rapid and significant increases occur in the wholesale price of fossil fuel-based energy due to market demand as the supply of fossil fuels begins to decline dramatically.
- Peak global production of Fossil Fuels occurs as follows:
 - Petroleum → peaks prior to 2010
 - Natural Gas → peaks in 2030-2040
 - Coal → peaks in 2060-2070
- Electrical Power Generation (early in the Century):
 - Primary Commercial Baseload Electrical Power @ higher than in 2010 (e.g., approximately 10¢-20¢/kilowatt-hour)
 - Remote / Leveraged Commercial Baseload Electrical Power @ higher than in 2010 (e.g., approximately 50¢-\$1.00/kilowatt-hour)
 - Premium Niche Market Electrical Power @ higher than in 2010 (for example, approximately \$4.00-\$5.00 /kilowatt-hour)
- Electrical Power Generation (late in the Century):
 - Primary Commercial Baseload Electrical Power @ much more than 2010 (for example, approximately 40¢-50¢/kilowatt-hour)
 - Remote / Leveraged Commercial Baseload Electrical Power @ much more than 2010 (e.g., approximately \$1.00-\$2.00/kilowatt-hour)
 - Premium Niche Market Electrical Power @ much more than 2010 (e.g., roughly \$8.00-\$10.00 /kilowatt-hour)

“Green Policies Work Out” (Scenario Delta)

This Scenario postulates a highly positive outcome for current national and international policies to develop new, more sustainable energy sources while increasing the efficiency with which we use all energy sources. These advances are driven by the goal of reducing Green House Gas (GHG) emissions, and occur before any significant depletion of fossil fuels occurs. Scenario 1 anticipates that significant reductions in GHG emissions will be achieved as a result of these technology developments, coupled with regulatory actions (e.g., requiring carbon sequestration) and market-based actions (e.g., “carbon trading”).

Because of these developments, in this Scenario there are few or only modest global climate change impacts due to past GHG accumulations.

Key aspects of this scenario include:

- There are substantial Investments in new, more-sustainable Energy Technologies, and these R&D investments are fully successful.
- Policy-driven regulatory changes are made, including high mileage standards, legislative requirements for increasing percentages of carbon-neutral energy, etc.
- Significant increases occur in the net price of fossil fuel-based energy due to market based and regulatory actions.
- Peak global production of Fossil Fuels occurs as follows:
 - Petroleum → peaks in 2010-2015
 - Natural Gas → peaks in 2040-2050
 - Coal → peaks in 2060-2070 (driven by technology substitution)
- Electrical Power Generation (early in the Century):
 - Primary Commercial Baseload Electrical Power @ more than 2010 (e.g., approximately 8¢-15¢/kilowatt-hour)
 - Remote Commercial Baseload Electrical Power @ more than 2010 (for example, roughly 35¢-75¢/kilowatt-hour)
 - Premium Niche Market Electrical Power @ about the same as 2010 (e.g., approximately \$2.00-\$2.50 /kilowatt-hour)
- Electrical Power Generation (late in the Century):
 - Primary Commercial Baseload Electrical Power @ somewhat more than 2010 (for example, 10¢-20¢/kilowatt-hour)

- Remote Commercial Baseload Electrical Power @ somewhat more than 2010 (e.g., about 50¢-\$1.00/kilowatt-hour)
- Premium Niche Market Electrical Power @ about the same as 2010 (e.g., roughly \$4.00-\$5.00 /kilowatt-hour)

6.3 SPS Market & Economics Assessment

Energy, environment and economic issues will likely be prominent throughout this century. A scenario-based approach such as that discussed here obviously does not reflect in-depth simulation or modeling of markets or prices in the remainder of this century. Rather, the approach is intended to synthesize the differences at a conceptual level among the four scenarios in terms of energy prices in markets of interest for SPS-delivered power, and to establish a framework for comparisons of the various SPS systems architecture options defined by the IAA study.

Example Comparison: GSP versus SSP Energy Payback Time

Another major consideration for any renewable energy system is that of the energy payback time (EPT) for the system – basically how long will it require for the system to produce as much energy as was required to manufacture, transport and assemble that system? The following are the major contributors to the total energy cost and the EPT of an SPS platform:

- Energy produced per year;
- Energy required in system manufacturing;
- Energy required for Earth-to-orbit (ETO) transportation;
- Energy required for in-space transportation (IST);
- Energy required for ISAAC operations; and,
- Energy cost of annual O&M activities.

The correct approach to analyze the energy required in system manufacturing – for either an SSP or a GSP system – would be to calculate the hardware energy content for both SSP and GSP via appropriately constructed input-output matrix, and to compare the results to the total energy produced annually by the renewable energy system. This level of rigor is beyond the scope of the present study, however. A tractable, first order approach is to examine just three factors:

- Energy produced per year;

- Minimum energy required for Earth-to-orbit (ETO) transportation; and,
- Minimum energy required for in-space transportation (IST).

As discussed elsewhere in this report, the minimum energy required for ETO transport to LEO can be calculated from the change in velocity (delta-V, or “Δv”) required, or approximately 9,000 meters per second. Similarly, for low thrust propulsion systems the energy required for IST transport from LEO to GEO can be calculated from the Δv required, or approximately 4,300 meters per second. For each kilogram of SPS platform, this is equivalent (using Kinetic Energy (i.e., “KE”) = ½ * m*v²) to total likely minimum transportation energy equivalent to approximately:

$$KE \sim \frac{1}{2} * 1 * 10^8 \text{ kg}\cdot\text{m}^2/\text{s}^2 \sim 50 \text{ Mega-Joules} \leq 14 \text{ kW}\cdot\text{hours}$$

In the case of a 10,000,000 kg SPS that produces 1 GW of power output on Earth, the annual energy produced per kilogram is roughly:

$$\begin{aligned} \text{Annual Energy} &= 8,766 \text{ hrs} * (1,000,000 \text{ kW} / 10^7 \text{ kg}) \\ &\sim 877 \text{ kW}\cdot\text{hours per kg}\cdot\text{year} \end{aligned}$$

Comparing the two results, the time require for an SPS with these characteristics to payback the energy of launch and in-space transportation would be approximately:

$$\begin{aligned} \text{Transport Energy Payback Time} &\sim 0.016 \text{ years} \\ &\sim 0.2 \text{ months} \sim 5\text{-}6 \text{ days} \end{aligned}$$

Of course, in an actual SPS deployment, there will be additional energy costs due to the vehicle systems hardware being used, as well as inefficiencies in the transportation systems (e.g., excess propellant in the tanks, etc.). However, the above simplified analysis indicates in a straightforward fashion that the energy payback time due to transportation of the SPS hardware to GEO can be expected to be approximately 1 week, and therefore insignificant in duration. (Even if the SPS produces only 50 percent as much power per unit platform mass, the energy payback time due to transportation to GEO would only be increased to 2 weeks – still an insignificant contribution to the overall economics of the system.

Scenario-Based Assessment Summary

The scenario-based assessment performed for the IAA study provides interesting general insights into the potential market cases in which SPS

delivered energy could be competitive during the coming century – and at what types of price points. Table 6-1, and Table 6-2 provide a summary of the overall market framework that has been formulated here.

6.4 Summary

Each of the four Scenarios described in the paragraphs above is intended to capture a particular possible aspect of the future – and to provide a tangible context for laying out more detailed architectures and concepts-of-operations for future Solar Power Satellites. Specific architectures for SPS (e.g., lower cost, larger-scale RF systems versus high-cost, smaller-scale laser systems) may then be compared in terms of their potential to meet the energy requirements of the several Scenarios. The characterizations of possible future energy costs presented here **are not** intended as literal / quantitative forecasts; instead they are formulated to suggest what sorts of SPS systems might be more or less profitable depending on the Scenario in question.

Based on these cases, the most dramatic increases in the cost of primary baseload power might be expected in the later term if available supplies of key fossil fuels begin to drop behind market demand earlier in this century rather than later. However, strong “green energy” policies could lead to the most favorable nearer-term environment in such primary markets. These policies would result in higher prices in the nearer term, but avoid the market risks of either fossil fuel depletion earlier than hoped (Scenario Gamma) or significant climate change (Scenario Beta) in the mid-to-latter half of the century.

In all cases, PNM’s represent attractive options. Remote and/or leveraged commercial markets appear particularly attractive in all cases, but especially in the case of Scenario Gamma (“Fossil Fuels Run Out”) in which conventional fuels are depleted, but no special preparations are made early enough to offset the resulting energy price increases.

Table 6-1 Summaries of Scenarios and Resulting Market Assessment

		Scenario Alpha	Scenario Beta	Scenario Gamma	Scenario Delta
		<i>"Business as Usual Works Out"</i>	<i>"The Frog Gets Cooked"</i>	<i>"Fossil Fuels Run Out"</i>	<i>"Green Policies Work"</i>
Policies	Green Energy R&D	Modest Investments, continuing	Minimal Investments, Modest Later	Modest Investments, Significant Later	Significant Investments, Early & Continuing
	GHG Regulations	Moderate Regulation of GHG Emissions	Minimal Regulation of GHG Emissions	Minimal Regulation of GHG Emissions	Significant Regulations, Early & Continuing
Fossil Fuels Forecast	Petroleum	Peaks circa 2010-2015	Peaks circa 2020-2030	Peaks Before 2010	Peaks circa 2010-2015
	Natural Gas	Peaks circa 2060-2080	Peaks circa 2080-2100	Peaks circa 2030-2040	Peaks circa 2040-2050
	Coal	Peaks circa Post 2100	Peaks circa Post 2100	Peaks circa 2060-2070	Peaks circa 2060-2070

Table 6-2 Scenarios Summary & Market Assessment: Forecast³⁵

		Scenario Alpha		Scenario Beta		Scenario Gamma		Scenario Delta	
		<i>"Business as Usual Works Out"</i>		<i>"The Frog Gets Cooked"</i>		<i>"Fossil Fuels Run Out"</i>		<i>"Green Policies Work"</i>	
		Early	Later	Early	Later	Early	Later	Early	Later
Electrical Power Markets Forecast (\$/kW-hour)	Primary Baseload Markets	5¢-10¢ per kW-hr	10-20¢ per kW-hr	5¢-10¢ per kW-hr	15¢-30¢ per kW-hr	10-20¢ per kW-hr	40-50¢ per kW-hr	8¢-15¢ per kW-hr	10-20¢ per kW-hr
	Remote / Leveraged Commercial Markets	25-50¢ per kW-hr	50¢-\$1 per kW-hr	25-50¢ per kW-hr	75¢-\$1.5 per kW-hr	50¢-\$1 per kW-hr	\$1-\$2 per kW-hr	35-75¢ per kW-hr	50¢-\$1 per kW-hr
	Premium Niche Markets	\$2-\$2.50 per kW-hr	\$4-\$5 per kW-hr	\$2-\$2.50 per kW-hr	\$6-\$8 per kW-hr	\$4-\$5 per kW-hr	\$8-\$10 per kW-hr	\$2-\$2.50 per kW-hr	\$4-\$5 per kW-hr

Future integrated end-to-end systems studies of SPS should include rigorous examinations of the economic framework for SPS platforms. A scenario-based approach could provide the most comprehensive approach to such studies.

³⁵ Please note that the specific price points for different energy sources delineated in Table 6-2 are **not intended** to be interpreted as a literal, quantitative forecast. Rather, they are presented strictly as suggestive of what might be expected as a result of the emergence the different alternative futures sketched in Table 6-2.

CHAPTER 7**PRELIMINARY SYSTEMS ANALYSIS RESULTS**

The objectives of the systems analysis conducted by the IAA were to understand better the high-level issues that constrain SPS/SSP design choices in general, and to enable an analytical comparison among the three SPS types considered by the study. These issues included (a) key drivers from the physics of SPS and/or WPT systems; (b) selected critical technology issues; and, (c) parametric cost considerations. Where possible, the first order sensitivities among SSP/SPS engineering parameters were developed. Also, expected cost sensitivity in terms of the key SPS figures of merit (identified in Chapter 6) were examined.³⁶

This chapter presents the results of the preliminary systems analyses, including the SPS platforms and supporting systems options.

7.1 Systems-Technology Considerations

The resolution of a number of systems-technology issues is critical to the future economical viability of SSP. The “Top-10” challenges that must be addressed successfully include the following:

- Frequency Selection and Atmospheric Interactions
- WPT end-to-end efficiency and Transmitter / Receiver Diameters
- WPT Beam Intensity at Receiver
- Solar Power Generation (SPG) / Power Management and Distribution Specific Mass
- Thermal Management System (TMS) mass-effectiveness
- WPT Beam Generation Device Selection and Transmitter Rigidity
- SPS Platform and Supporting Infrastructure Mass per Unit Power Transmitted/Received
- ETO Launch Vehicle – Lift Capacity and Expendability
- In-Space Transportation – Utilization of Fixed Capacity
- Platform and Operations Autonomy

³⁶ See Appendix F for a summary of the systems analysis methodology used by the study group.

- Integration of Space and Ground Solar Power

The following paragraphs explore each of these systems-technology issues in more detail.

Frequency Selection and Atmospheric Interactions

Overview. The foundation of design choices for SPS systems and the selection of SPS technologies is a consideration of the emissivity of Earth's atmosphere to differing portions of the electromagnetic (EM) spectrum. See Figure 7-1 for an illustration of the attenuation of EM radiation through the atmosphere. As shown, Earth's atmosphere is largely opaque to EM radiation, however there are several "windows" – specific wavelengths at which the atmosphere is essentially transparent.

Figure 7-1 Atmospheric EM Attenuation at Various Wavelengths

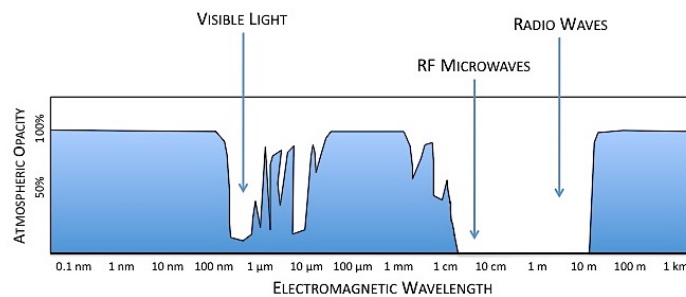

Credit: Artemis Innovation Management Solutions LLC

Obviously, the atmosphere is essentially transparent at wavelengths near that of visible light. However, there for wireless power transmission applications, there are evident issues associated with atmospheric water vapor and weather (fog, clouds, haze, etc.). The atmosphere is also transparent across a wide range of RF wavelengths, between 10 meters and 1 cm. Figure 7-2 illustrates the details of atmospheric opacity to RF wavelengths in this range.

Radio Frequency (RF) WPT

RF spectrum use is managed by the International Telecommunications Union (ITU), through a series of working groups focused on specific scientific and engineering issues. Several specific frequencies are reserved for non-communications applications: the Industrial, Scientific and Medical

(ISM) bands. Two of these ISM bands are of particular interest in prospective SPS and WPT applications: 2.45 GHz and 5.8 GHz. These frequencies fall well within the range in which the RF attenuation by the atmosphere is least.

Frequencies in the range from 2 to 10 GHz – i.e., microwave RF – represent promising candidates for SPS WPT. As Figure 7-2 illustrates, at lower wavelengths (i.e., higher frequencies, atmospheric and/or weather-related attenuation increases drastically.

Figure 7-2 Atmospheric Attenuation of RF at Various Wavelengths

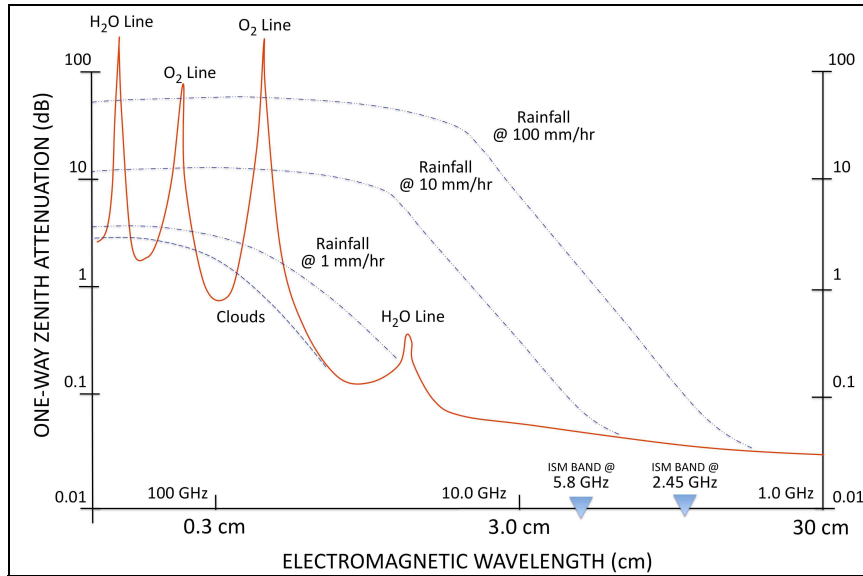

Credit: Figure Provided by Artemis Innovation Management Solutions, 2010, after NASA Ref. Pub. 1082(04), Feb. 1989

Near-Visible (Laser) WPT

In the case of a laser WPT approach, the typical frequency of interest is in the near-Infrared (near-IR) portion of the spectrum, with a wavelength of approximately 0.00000098 meters (or roughly 980 nm, corresponding to a frequency of 306,122 GHz). (Note that the physics illustrated in Figure 7-3, discussed below apply equally to microwave and to laser WPT optical systems.) In the laser WPT case, the transmitter and receiver diameters can be made considerably smaller than the RF cases. However, there will be

significant interactions (absorption) by weather phenomena increasingly from haze to cloud cover to storms with increasing water droplets in the air.

A key driver for laser (but also for RF) WPT concepts is the issue of maximum beam intensity at the receiver. This topic is discussed further in below.

Figure 7-3 Transmitter / Receiver Scaling Relationships

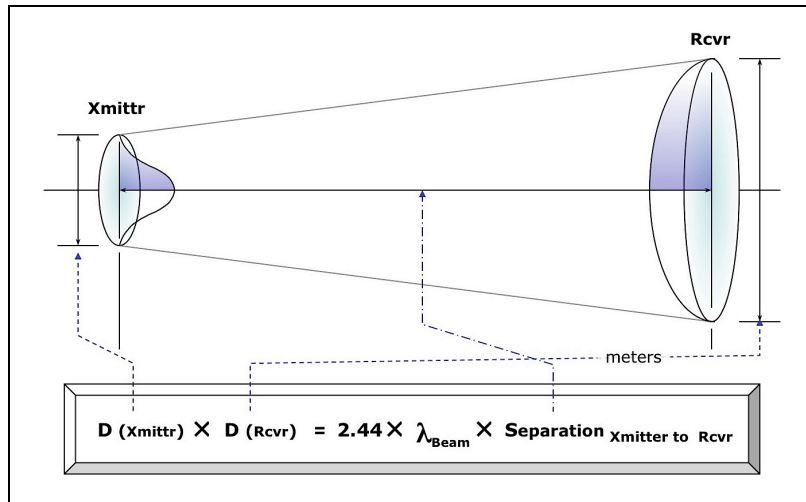

Credit: Figure Provided by Artemis Innovation Management Solutions LLC

WPT End-to-End Efficiency and Transmitter / Receiver Diameters

Overview. The typical power distribution across the face of the transmitter for an RF wireless power transmission system for SPS Type I or SPS Type III in this study is a Gaussian distribution in which the peak power (at the Center of the transmitter) is 10-times greater than the power at the edge of the transmitter. (A Gaussian distribution delivers the theoretically highest beam coupling efficiency between the transmitting antenna and the receiver on Earth.) Figure 7-3 illustrates the key parameteric relationships that relate the wavelength of the beam, λ_{Beam} the diameter of the transmitter, $D_{(Xmitter)}$ and the distance over which the beam travels, $\text{Separation}_{Xmitter\ to\ Rcvr}$ – to the optimum diameter of the receiver, $D_{(Rcvr)}$ on the ground.^{37, xliv}

³⁷ The factor of “2.44” in the equation presented in Figure 7-3 that relates the diameters of the transmitter and the receiver for a given frequency is a consequence of seeking to achieve a

In the case of a geostationary Earth orbit (GEO) based SPS, the separation distance from the transmitter to the receiver is 35,786,000 meters (i.e., somewhat less than 35,800 km or a little more than 22,000 miles), plus an varying additional distance that depends on the latitude of the receiver above the equator.

Radio Frequency (RF) WPT. In addition to the sizing of transmitter and receiver systems due to diffraction-limited optics, the key issues for WPT are the efficiencies with which the RF beam is generated on the platform and converted back into useful power (or stored as fuel) on the ground.

RF (Microwave) WPT Device Selection. Since World War II, electron tube devices for RF power generation, beginning with the cavity wave magnetron, have been able to achieve very high output power efficiency.^{xiv} Examples of RF tube device options include Magnetrons, Klystrons, and Traveling Wave Tubes (TWTs). Solid state RF devices were able to achieve only very poor RF power generation efficiencies in the 1970s. However, during the past decade, high efficiency, solid state Field Effect Transistors (FETs) for space applications have been developed with efficiencies approaching those of electron tubes in frequency ranges of interest for WPT.

Near-Visible Frequency (Laser) WPT. As in the RF case, the efficiencies of beam generation and conversion at Earth are critical to the overall power delivery system.

Near-Visible (Laser) WPT Device Selection. In recent years, solid-state laser arrays fabricated from collections of diode-pumped lasers have become efficient enough to represent promising candidates for near-visible WPT device selection.

WPT Beam Intensity at Receiver

The intensity of the wireless power transmission beam at the receiver is a key issue in the end-to-end design of an SPS system. Figure 7-4

high beam coupling efficiency between the two. In this case, the factor – also known as “Tau”– corresponds to a beam coupling efficiency of greater than 96-97%. This is equivalent to the physics of diffraction limited optics in imaging, where planar light is focused into an Airy disk with a diameter to the first null; i.e.,

$$\text{Diameter (Spot)} \times \text{Diameter (Lens)} = 1.22 \times l \times (\text{Focal Length})$$

summarizes the physics of the relationships that determine the maximum intensity at the center of a WPT beam in the case of a Gaussian transmission.

A special consideration for the design of SPS WPT systems is that of beam safety, namely what level of energy intensity (e.g., watts/meter-squared) at Earth is safe for humans, machines, fauna and flora? A very rough estimate of the temperature increase that would be experienced by an object illuminated by an RF or laser WPT transmission may be estimated approximately using the Stephan-Boltzman Law (S-B Law). (A simple calculation of this type may include convective cooling roughly.) This analysis is provided in Section 5.2, concerning the policy issue of possible weaponization of the WPT beam.

Figure 7-4 Physics of the EM Beam Intensity at the Receiver

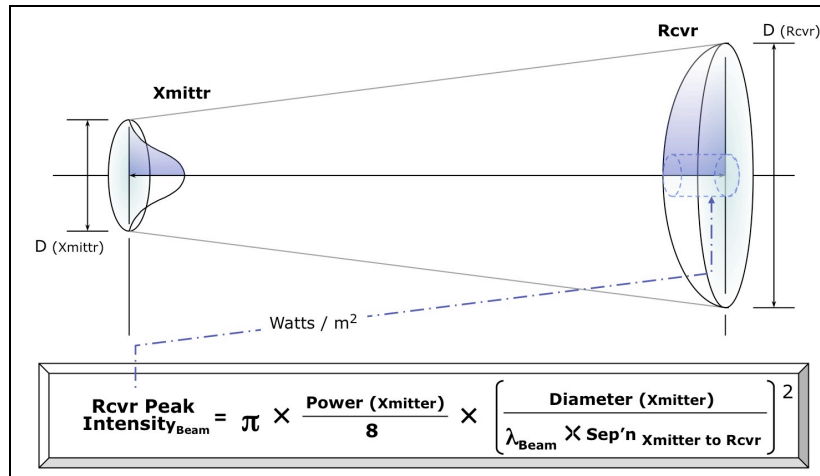

Credit: NASA Graphic / Edit by Artemis Innovation Management Solutions LLC

Moreover, here are several standard guidelines that have been discussed over the past 3-4 decades, as well as various government requirements for exposure to non-ionizing electromagnetic energy (including, for example microwave or laser beam exposure). Although legal limits vary from country to country, Table 7-1 presents typical upper limits for the intensity both types of EM energy.

In RF-based SPS studies, these limits are usually established at the edge of the received WPT energy; for example, at the outer end of the rectenna

in the case of a Gaussian microwave transmission. Guidelines for SPS studies include a general ground-rule for beam safety that the maximum energy per unit area for the system be less than normal sunlight.³⁸

Table 7-1 Examples: Legally-Defined EM Exposure Upper Limits^{34v}

Type of Limit	Laser	Microwave
Typical General Population / Cautionary Safety Limit	n/a	< 1-10 Watts / m ²
Typical Employee Safety Limits (Incidental Exposure / Viewing)	< 10 Watts / m ²	< 100 Watts / m ²
Typical General / Eye Safety Limit for Long Durations (>10 min)	< 25 Watts / m ²	n/a
Typical General / Eye Safety Limit for Short Durations (>10 sec)	< 50 Watts / m ²	n/a

In the case of microwave WPT, this guideline, coupled with considerations of transmitter diameter ($Diameter_{Xmitter}$ in Figure 7-4) and the distance from the Earth to GEO (“ $Sepr_{Xmitter-to-Rcvr}$ ” in Figure 7-4), and the wavelength of the beam (l_{Beam}) have resulted in a nominal transmitter diameter of about 1 km, and peak beam intensity at the receiver of approximately 200-250 watts/meter-squared. (This is about 1/5th to 1/4th of the intensity of mid-day sun at the equator.) This peak energy intensity at the center of the WPT receiver corresponds to energy intensity at the edge of less than 1 watt/m² (i.e., approximately or less than the upper limit for typical general population safety noted in Table 7-1).

Solar Power Generation (SPG) / Power Management and Distribution (PMAD) Specific Mass

Some of the key factors that drive the specific mass (mass per unit power) of the SPG (solar power generation) and PMAD (power management and distribution) elements of the SPS system include:

- The solar energy conversion efficiency per unit mass of the SPG system; i.e., the watts per kilogram of the SPG.
- The voltage of the SPG output, the voltage of the SPG PMAD system and the area of the SPG array.

³⁸ An integrated set of SPS / WPT safety ground rules / requirements are clearly needed to guide future research and development, demonstrations, etc.

- The voltage and the distances to be covered by the SPS platform PMAD system.
- The voltage of the WPT transmitter, and hence the voltage of the WPT PMAD system, and the area to be covered by the WPT PMAD system.

Of course, the specific elements of the SPG and PMAD functions that must be accounted for will depend entirely on the SPS Type selected, and on the details of the design that are involved.

Thermal Management System (TMS) Mass-Effectiveness

Some of the key factors that drive the specific mass (mass per unit waste heat to be radiated) of the TMS (Thermal Management) elements of the SPS system include:

- The solar energy conversion *inefficiency* per unit mass of the SPG system; i.e., the watts of waste heat per kilogram of the SPG that must be rejected by the SPG TMS.
- The solar energy conversion *inefficiency* per unit mass of the SPG system and the *inefficiency* in the SPG PMAD system and the area of the SPG array; i.e., the watts of waste heat per kilogram of the SPG that must be rejected by the SPG PMAD TMS.
- The *inefficiency* in the SPS platform PMAD system; i.e., the watts of waste heat per kilogram of the SPG that must be rejected by the SPS platform PMAD TMS.
- The *inefficiency* in the WPT PMAD; i.e., the watts of waste heat per kilogram of the WPT PMAD that must be rejected by the WPT PMAD TMS.
- The *inefficiency* in the WPT transmitter itself; i.e., the watts of waste heat per kilogram of the WPT that must be rejected by the WPT TMS.

Of course, the specific elements of the TMS that must be taken into account will depend entirely on the SPS Type selected, and on the details of the design that are involved. For purposes of the IAA study, the key parameters for an SPS thermal management system were examined by means of only a very simple analysis. The basis of this analysis was the Stephan-Boltzman equation:

$$\text{Power Radiated} = A \times e \times s \times T^4$$

In which, A is the area from which heat is being radiated, e is the emissivity of the surface, s is the Stephan-Boltzman constant (i.e., $s = 5.6704 \times 10^{-8} \text{ J s}^{-1} \text{ m}^{-2} \text{ K}^{-4}$), and T is the absolute temperature of the surface (in degrees-Kelvin).

WPT Beam Generation Device Selection and Transmitter Rigidity

A key technology choice for SPS transmitters is the selection what type of device will be used to generate the WPT beam. There are a number of options for both RF and laser WPT SPS concepts. The baseline options for each of the three promising SPS systems concept examined by the IAA study are:

- Type I, 1979 SPS Reference System Type; Baseline WPT Device Choice is: electron tube microwave devices. Characteristics of the WPT system include: local moderate voltage devices, semi- “clean” RF power (with some spectral variation across devices; and, a large rigid waveguide structure.
- Type II, Laser SPS Type; Baseline WPT Device Choice is: solid state laser diode array for near-visible IR beam generation, with physical gimbaling of a beam expander telescope for beam pointing. Characteristics of the WPT system include: local moderate voltage devices, low to moderate efficiencies, and significant requirements for waste heat removal.
- Type III, Modular Sandwich SPS Type; Baseline WPT Device Choice is: solid state amplifiers for RF beam generation with integrated phase shifter circuitry at the subarray level for electrical beam steering. Characteristics of the WPT system include: low local voltages, very “clean” RF devices, moderate waste heat requirements.

In the case of a solid state RF transmitter array using a retro-directive phased array for electronic beam steering, the phase reference provided by a remote pilot signal (located with the targeted receiver) may be used to dynamically adjust for small local curvatures of the transmitter surface.

Determination of the specific mass per unit area for an RF SPS WPT transmitter will require detailed design and analysis. However, there are examples that may be used to bound initial estimates. First, the mass of the transmitter for the 1979 SPS Reference System may be taken as an upper

limit for the RF waveguide approach, with no local phase shifting. The mass per unit area for this system is likely to be higher than for other options due to the requirement for the rigid waveguide structure.

Second, the mass of existing retro-directive phased array WPT transmitters (using off-the-shelf components and materials) may be taken as an upper limit for the Sandwich-type SPS WPT system, which includes local phase shifting. The mass per unit area for this system is expected to be lower than the waveguide option, with the potential for lower mass per unit area with advances in component technologies.

In both of these cases, potential improvements in the specific mass per unit area may be examined parametrically. Such improvements might be the result of innovative design, or to novel materials, or to use of integrated circuits (rather than discrete components in the case of the solid state option).

SPS Platform and Supporting Infrastructure Mass per Unit Power Transmitted / Received

One of the most fundamental FOMs for SPS is the total mass of the systems in space – and in particular the solar power satellite platform mass (and supporting infrastructure mass) per unit power recovered on the ground.

Physical Limits on Specific Mass. The melting temperature for selected materials from which an SPS would likely be fabricated is one way to establish a physical limit on the specific mass (mass per unit power) for an SPS. Based on reasonable expectations regarding the end-to-end efficiency of the system (e.g. about 50%), and using the Stephan-Boltzmann law relating radiating power and temperature, a theoretical maximum total power may be roughly estimated. For purposes of the analyses in this section, it is assumed that the SPS is of the RF type, with total mass of the SPS is 10,000,000 kg, and a Diameter of 1 km. Table 7-2 provides some results for typical SPS materials.

Electronics Operational Limits on Specific Mass. The maximum operating temperature for selected electronics components that might be incorporated an SPS represent another way to establish a physical limit on the mass per unit power for an SPS.

Table 7-2 Specific Power & Temperature Relationship for Materials

Typical SPS Material	Max Temperature* (°C)	Specific Power Delivered @ 50% end-to-end Eff. (Watts/kg)	TOTAL SPS Power @ 1 km Diameter
Aluminum	330 ° C	~ 370 Watts / kg	~ 4,700 MW
Copper	542 ° C	~ 1,800 Watts / kg	~ 15,800 MW
Stainless Steel	755 ° C	~ 3,000 Watts / kg	~ 38,000 MW
Carbon Nanotubes	1,400 ° C (in vacuum)	~ 30,000 Watts / kg	~ 263,000 MW

* Based on a maximum temperature of 50% of known Melting Point or Evaporation Point.

Based on reasonable expectations regarding the SPS system (see above), and using the Stephan-Boltzmann law relating radiating power and temperature, theoretical maximum total power may again be roughly estimated. Table 7-3 provides some results for typical types of electronics that might be used in a solar power satellite.

Table 7-3 Electronics Specific Power / Temperature Relationship

Typical SPS Electronics	Max Temperature* (°C)	Specific Power Delivered @ 50% end-to-end Eff. (Watts on Earth/kg)	TOTAL SPS Power Delivered at Earth (@ 1 km Diameter)
Silicon PV Cell	~ 40 ° C	~ 28 Watts / kg	~ 390 MW
GaAs FET Amplifier	85 ° C	~ 47 Watts / kg	~ 670 MW
Typical Resistors	100-125 ° C	60-70 Watts / kg	800-900 MW
Typical Amplifiers	100-125 ° C	60-70 Watts / kg	800-900 MW
Silicon Carbide Devices ^{4vi}	500-600 ° C	1000 - 1,700 Watts / kg	12,000 – 21,000 MW

* Based on cited maximum operating temperatures for various electronics devices.

Example Analysis: Specific Mass in terms of Energy Payback. The total mass of SPS systems in GEO that is required to deliver a given amount of energy to terrestrial markets is a critical figure of merit for space solar power. This comprises not only the SPS platform mass, but also the mass of supporting GEO-based infrastructure required to support key SPS functions – for example space assembly, maintenance and servicing. For example, the amount of mass comprising this infrastructure over and above

the SPS platform will directly lengthen the energy payback time for the solar power satellites that it supports. Figure 7-5 presents a highly simplified analysis of this issue, showing for transportation energy only the sensitivity of the SPS energy payback time to the mass of the GEO-based SPS and supporting infrastructure (for a single satellite).

Figure 7-5 SPS Sensitivity of Energy Payback Time to GEO Mass

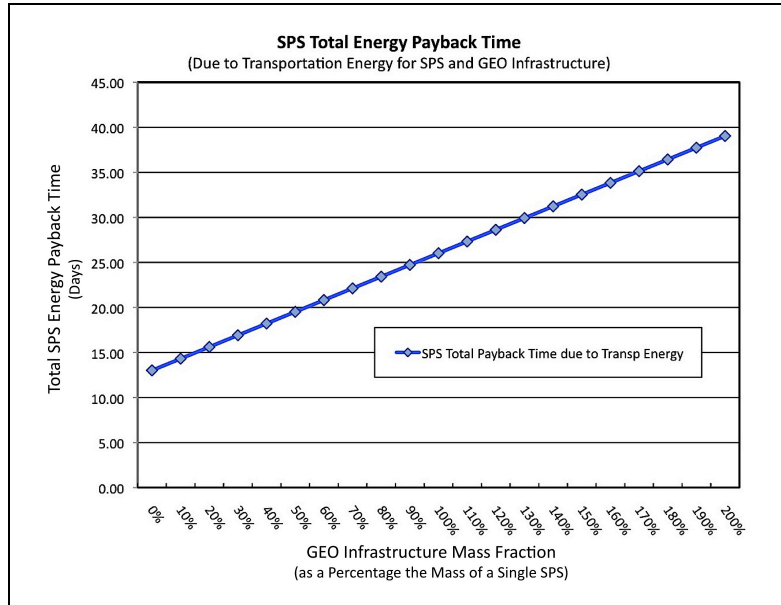

Credit: Artemis Innovation Management Solutions LLC (2011)

In the case analyzed, the assumptions were (a) that single SPS was deployed; (b) that the mass of the SPS was 10,000,000 kg and the power it delivered was 1,000 MW; and, (c) that the delta-velocity from Earth to GEO was roughly 15,000 meters per second. The mass of the GEO supporting infrastructure is varied from 0% to 200% of the SPS platform mass, in steps of 10%. Also, Figure 7-5 reflects only the energy payback time due to the transportation energy cost of launching to GEO the infrastructure, for a single solar power satellite.

If that infrastructure were to be used (as is highly likely) for the deployment and maintenance of multiple solar power satellites, then it seems likely that the energy cost of such supporting systems will not be significant in determining SPS economic viability. Future, far more detailed

systems analysis studies are clearly needed, however the development cost of the supporting infrastructure seems likely to be far more critical than energy cost – particularly for large, monolithic platforms (analogous to the ISS) could be in the range of \$50,000-to-\$200,000 per kilogram. When economic factors such as net present value (NPV) calculations are taken into account by more rigorous analysis, this emphasis on early development cost for supporting infrastructure will likely be upheld.

Observations. Clearly, for lightweight SPS (e.g., about 10,000 MT for a 1 km diameter transmitter), the basic materials out of which the platform might be fabricated present no significant limitation based on operating temperature. (See Table 7-3.) Any reasonable combination of materials such as Aluminum, Stainless Steel, or advanced composites will not be at risk due to high temperature operations. However, for most typical electronics devices that might be used, the maximum operating temperature represents a far more significant restriction. Conventional solar cells represent the most significant limitation.

There appear to be three potential solutions to these issues. First, an SPS architecture that separates sensitive electronics from high temperatures – such as the 1979 SPS Reference System – may be used. Second, novel thermal management technologies may be sought that provide can cool temperature-sensitive elements. Finally, advanced materials may be applied successfully in high-efficiency electronics – such as SiC – that could enable entirely acceptable levels of power output at relatively high temperature.

ETO Launch Vehicle – Launch Capacity and Expendability

Introduction. One of the most important cost considerations that will determine the economics of space solar power is that of Earth-to-orbit (ETO) transportation. The following paragraphs examine selected key aspects of the physics of ETO and relate these to questions of launch vehicle capacity and expendability.

The Rocket Equation. Of course, the critical physics for space transportation of almost all types is the rocket equation. The rocket equation expresses the mathematical relationship among the initial mass and the final mass of a rocket-propelled object (M_{initial} and M_{final} , respectively), the change in velocity experienced by the object (“delta-v”, or “ Δv ”), the

specific impulse produced by the rocket, and finally a term to normalize the units,³⁹ one Earth’s gravity (Isp and g, respectively).

The equation is:

$$Mass\ Ratio = \frac{M_{initial}}{M_{final}} = e^{(\Delta v / Isp \times g)}$$

The Isp is a reflection of the propulsion technology involved (in particular, the fuel efficiency of the propulsion system); represents the change in the momentum of the rocket per amount of propellant consumed by the rocket. Table 7-4 summarizes the Isp for several rocket engines of potential interest for SPS launch and deployment.

Table 7-4 Comparison of Isp for Various Propulsion Technologies⁴⁰

Propulsion Technology	Specific Impulse (Isp)	Notes
Chemical Propulsion: Solid Rocket Motor	250 seconds	These are high thrust systems; expendable upper stages would typically be incorporated into such a system
Chemical Propulsion: Hydrocarbon	350 seconds	These are high thrust systems; a bi-propellant approach such as Liquid Oxygen and RP (a hydrocarbon); a first stage in an ETO system might use this technology
Chemical Propulsion: Cryogenic	420-460 seconds	These are high thrust systems; Liquid Oxygen (LOX) and Liquid Hydrogen (LH2) propellants may be used; the RL-10 is such a system
Electric Propulsion: Hall Effect / Ion	3,000 seconds	These are low thrust systems that require kilowatts of power or more; a typical propellant might include Xenon
Electric Propulsion: Plasma Thruster	10,000-30,000 seconds	These are very low thrust system concepts that require 100s of kilowatts of power or more; a typical propellant might include Hydrogen; the VASIMR thruster is such a system

The $M_{initial}$ comprises four constituents: (a) the weight of the vehicle being launched, (b) the weight of the payload (if any) being carried by the

³⁹ The use of “g” (the acceleration of gravity on Earth) is due to the expression of propellant in terms of its weight on Earth, rather than its mass; both are common. In the case that mass is used, then Isp is expressed in units of “meters per second”; alternatively, if the weight is used, then Isp is expressed in units of seconds. The latter units are used in this report.

⁴⁰ There are, of course, a wide variety of alternative propulsion systems not listed here (e.g., aerobraking, rotating tethers, etc.). The focus here is on selected promising candidates that highlight key systems trade space options associated with the launch and deployment of SPS in the coming 10-20 years.

vehicle, (c) the weight of the propellant to be consumed in the maneuver, and (d) residual propellant (if any) that may be left after the rocket-propelled maneuver is completed. The total change in velocity needed to launch a rocket from Earth to LEO is approximately 9,500 meters per second.^{xlviii} (This total Δv includes the final velocity, the drag during launch, and gravity losses during launch. It depends on the location of launch site as well, due to the rotation of Earth.)

For current materials and structures, the vehicle mass fraction for reusable vehicles remains unacceptably low, meaning that the vehicle itself is too great a fraction of the gross lift off weight (GLOW) of the total (comprising the vehicle, its propellants and the payload).

The preliminary, physics-based analysis of this technical hurdle indicates that the trade space comprises several important considerations; these include: (1) launch capability (payload vs. ETO systems hardware vs. ETO gross lift-off weight (GLOW)); (2) reusability vs. expendability (including fractional expendability); (3) lifetime (for reusable systems); and, (4) the manufacturing curve (aka, the “learning curve”) for both ETO systems hardware.

Each of these systems architecture trade options is examined in more detail in the paragraphs that follow.

ETO Cases. The following cases have been examined as part of the IAA’s SSP study effort: (a) existing expendable launch vehicles (ELVs); (b) new SPS-dedicated ELVs; (c) new SPS-dedicated heavy lift launch vehicles (HLLVs); (d) new SPS-dedicated reusable launch vehicles (RLVs), including both moderate size and HLLV size payload vehicles; (e) new reusable launch vehicles (RLVs), that serve multiple markets, including SPS (designated as “shared”); and, (f) new SPS-dedicated RLV that has a 2-times longer lifetime than other RLV cases. Each of these cases is examined in terms of four different market options, concerning both an SPS pilot plant and launch to LEO of either a single or multiple SPS platform. The detailed results of the analysis of the several specific ETO cases is presented below in Section 7.5

Observations. Several strategic conclusions can be drawn even from the high-level analysis that has been discussed here. For example, only through the development and deployment of reusable ETO transportation systems can the exceptionally low cost launch required for SPS to deliver

power cost-effectively to commercial baseload markets be achieved. However, for early demonstrations and pilot plants, existing ELVs are clearly the most cost-effective launch system. As the planned number of SPS to be launched increases, then large payload RLVs of the type examined in the 1970s ERDA / NASA SPS studies become increasingly cost-effective.

However, the initial investment required for these systems is quite large, suggesting that for the initial launch of modular SPS smaller RLVs are preferred – and that the longer lived launch vehicles are significantly lower in cost than shorter-lived systems.

In-Space Transportation – Utilization of Fixed Capacity

As was the case for ETO systems, the rocket equation represents the critical aspects of the physics to be considered in examining in-space transportation for SPS deployment and operations. Table 7-5 highlights the energetics (measured in meters per second of changes in velocity) of the key transfer maneuvers required.

Table 7-5 Space Transfer Energetics

Transfer Maneuver	High-Thrust	Low-Thrust	Aeroentry return from GEO
ETO-to-LEO	~ 10,000 m/s	n/a	n/a
LEO-to-GEO	~ 4,300 m/s	~ 5,800 m/s	n/a
GEO-to-LEO	~ 4,300 m/s	~ 5,800 m/s	< 1,000 m/s (plus A/B MF @ ~15%)

Propulsion Options and Time. The principal propulsion options are cryogenic chemical propulsion and solar electric propulsion. For in-space transportation systems, such as would typically be used to move SPS elements from LEO to GEO, a key issue is that the high-thrust systems that could provide fast round-trip times are comparatively low in fuel efficiency (with Isp of 250-460 seconds), while the systems that provide high fuel efficiencies (with Isp of 3,000 seconds or more) are low-thrust and are not capable of achieving fast trip times. Moreover, the use of low-thrust systems results in an increase in what are known as “gravity losses” –

i.e., the proportion of fuel that must go to lift the vehicle against gravity, versus adding directly to the vehicle's velocity.⁴¹

Observations. Some of the key factors that would significantly improve the cost of in-space transportation for SPS deployment and operations include:

- (1) Orbital Transfer Vehicle (OTV) Hardware Costs
- (2) OTV Roundtrip Times
- (3) Earth-to-Orbit Transportation Costs
- (4) OTV Propulsion Specific Impulse (Isp)

These FOMS must be addressed by SSP supporting infrastructure related R&D.

Platform and Operations Autonomy

Introduction. During the course of space mission operations, the number of personnel as full time equivalents (FTEs) can be an important driver of life cycle cost (LCC). The principal roles for these persons can typically include: (a) mission operations; (b) sustaining engineering staff (including engineering staff required for software operations and maintenance); and, (c) overhead/management staff. Autonomy – i.e., the capability for SSP systems to operate with minimal ground-based personnel support – is a secondary driver when compared to the cost of SPS platform hardware or the cost of SPS space transportation, but it can become significant for long-lived systems.

Key Drivers. Key drivers for platform and operations autonomous will concern the technology that can be incorporated into the SSP systems (e.g., in onboard computing, sensors, avionics, etc.).

Observations. Clearly, significant improvements will be required for SPS operations beyond the level of autonomy that characterizes most current space systems. Platform and operations autonomy can make important contributions to reducing space mission life cycle costs by reducing the number of ongoing personnel involved.

⁴¹ For example, imagine a Saturn V booster that is operating at near full power, just at liftoff: a tremendous amount of propellant is being burned, but little or no velocity is being added. At that point in the launch, almost all of the fuel used goes into lifting against gravity.

Integration of Space and Ground Solar Power

Introduction. An architecture level design question vis-à-vis SPS ground receivers is whether or not (and if so then how) to integrate ground solar power (GSP) systems with wireless power transmission (WPT) receivers for space solar power (SSP). The principal advantage of this concept is in the effective exploitation of “low cost” sunlight when it is available, and the use of “higher cost” WPT radiant energy when necessary—thus maximizing the use of the land area dedicated to the system, as well as the potential for tailoring the power delivered to the changing hourly requirements of the local market. There are several different alternatives.

Laser / Ground Solar Integration. The most typically discussed case is the dual-use of laser SPS receivers (tailored bandgap PV arrays) to generate power both from the laser WPT beam and (during daylight hours) sunlight. This case was explored in some detail as part of SSP studies conducted by the European Space Agency (ESA) during 2002-2004.

Microwave / Ground Solar Integration. Another option is to integrate in the same location a Rectenna with standalone solar PV arrays or concentrator solar power (CSP) systems that generate power through a heated working fluid and solar dynamic engines. In this case, the two systems would most likely be separately connected to the local power grid. This approach depends upon the development and deployment of a mesh-type Rectenna with discrete electrical elements that can allow as much as 80% or more of the incident sunlight to pass through the RF receiver, while intersecting essentially 100% of the microwave WPT beam.

A number of key questions must be resolved to determine whether this approach is economically advantageous, including (a) the cost per watt-generated for the dual-purpose PV system *versus* separate microwave Rectenna plus optimized solar array; and (b) the probability of system failure and repair/maintenance requirements for the two options.

Comparison of Options. Table 7-6 on the page following summarizes some of the advantages (“pros”) and disadvantages (“cons”) of these two distinct SSP-GSP combination approaches.

Table 7-6 Comparisons of Laser and Microwave Approaches to SSP-GSP Combinations

SSP-GSP Combination Options	Pros	Cons
Laser WPT PV – Sunlight PV Fully-Integrated System	<ul style="list-style-type: none"> • Requires a single ground PV array system • Requires a single grid connection • No obstruction of incident radiant energy from either SPS or sunlight 	<ul style="list-style-type: none"> • Deployed angle of the PV array cannot be simultaneously optimized for both WPT and solar flux • PV tailored bandgap cannot be simultaneously optimized for both WPT and solar flux • Grid connection must be built to maximum power production (likely oversized for average power)
Microwave WPT – Sunlight PV Co-located System	<ul style="list-style-type: none"> • Deployed angle of the PV array <u>and</u> angle of microwave Rectenna can be simultaneously optimized for WPT and solar flux • PV can be optimized for solar flux • Grid connections can be built separately to overall power production 	<ul style="list-style-type: none"> • Inherent 20% obstruction of incident radiant energy from sunlight by Rectenna • Requires two receivers: one for microwave WPT and one for ground PV array system • Requires two grid connections & PMAD systems

7.2 Key Figures of Merit

In order to perform a useful high-level systems analysis and comparison of various SPS concepts, it is critical to establish the key figures of merit (FOMs) that relate the basic engineering of SPS platforms and supporting systems to the costs and economics of solar energy from space.

This section summarizes the key FOMs for both SPS platforms and relevant supporting systems and infrastructure.

Key Figures of Merit – SPS Platforms

The following are some of the key figures of merit (FOMs) for SPS:

- SPS Platform Mass per kW of power delivered on Earth (kg/kW)
- SPS Platform Cost per kg of Installed Mass (\$/kg)

- WPT End-to-End Efficiency (Power Generated on SPS / Power Output on Earth)
- SPS Level of Autonomy (Labor Hours per SPS Kilogram-Year of Operations)
- Personnel Cost per Hours for Installed SPS Hardware unit Mass Operations (\$/kg-hr)

Additional SPS Platform FOMS, including more detailed parametrics are provided below.

Key Figures of Merit – Supporting Systems & Infrastructure

The following are some of the key figures of merit (FOMS) for SPS supporting systems and infrastructures:

- ETO Cost per Installed SPS Hardware unit Mass (\$/kg)
- In-Space Transport Cost per Installed SPS Hardware unit Mass (\$/kg)
- Supporting Infrastructure Personnel Cost per Year for Installed SPS Hardware unit Mass Operations (\$/kg-yr)

Additional SPS Supporting Systems and Infrastructure FOMS, including more detailed parametrics are provided below.

Interrelationships Among SSP Key Figures of Merit

There is a complex set of interrelationships among various key FOMS for space solar power and supporting systems; this includes characteristics as diverse as choice of spectrum for the WPT system, the orbital location of the platform and labor hours per unit of WPT transmitter hardware. Figure 7-6 below provides a high-level summary of some of these interactions.

7.3 Preliminary Cost Analysis: Limits Analysis Approach

It is clear from the intricate interrelationships among SPS system characteristics (see Figure 7-6) that detailed end-to-end systems analysis studies of various markets, technologies and systems architectures for solar power satellite options are needed. Unfortunately, such studies are beyond the scope of the present IAA effort. However, there is an effective first-order analysis method that can yield important insights concerning the most important SPS system design issues with far less effort: the “Limits Analysis” approach.

This analytical method has three key parts. Part 1 is the formulation of a single, comprehensive “cost summary equation” (CSE) for the system or architecture being examined (in this case, SPS). Part 2 is the incorporation key FOMs (e.g., mass per unit power) into the CSE. Finally, Part 3 is the examination of high-level cost or economic outcomes in terms of highly focused variations in a specific FOM within the CSE. For the IAA study of SPS, the “Limits Analysis” were used to identify the most important “limits” for key figures of merit that are related to the eventual economic performance of SPS.

Figure 7-6 Network of Systems-Technology-Market Relationships”

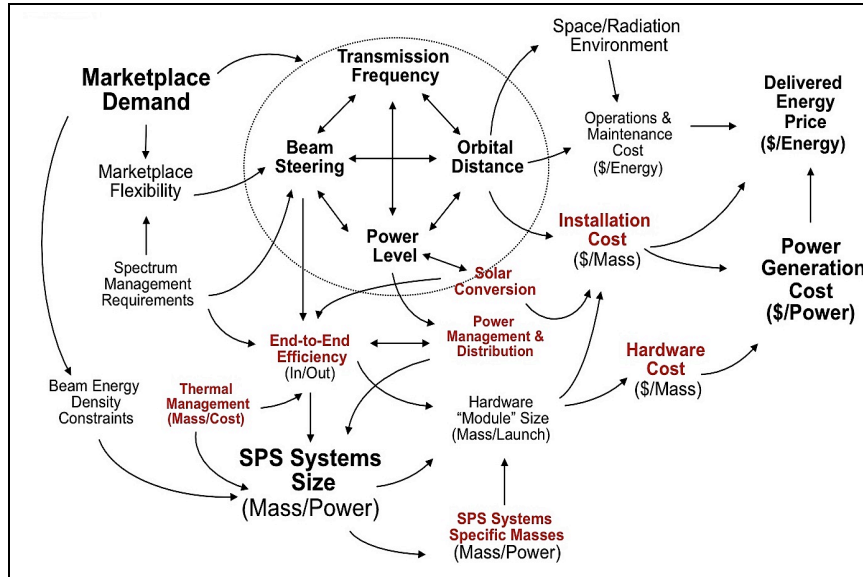

Credit: Artemis Innovation Management Solutions LLC

The following are the architecture-level and systems-level FOMs that were examined by the IAA study using a Limits Analysis approach:

- Delivered Power Cost per Unit Power Delivered on Earth (\$/kW-hour)
- Delivered Power Cost per Unit Mass of the SPS Platform (\$/kg)
- Manufactured Cost per SPS Platform Hardware Unit Mass (\$/kg)
- SPS Platform Hardware Unit Mass per Unit Power Delivery Capacity (kg/kW)

- Annual Labor Hours per unit SPS Hardware Mass (Hrs/kg-year)
- Solar Power Generation Power per unit Mass (W/kg)
- ETO Cost per Installed SPS Hardware unit Mass (\$/kg)
- Annual Fractional Expendability per SPS Platform unit Mass (% of SPS Mass /Year)
- Number of Modules per SPS (Number)
- SPS Hardware Manufacturing Learning Curve (H/W cost reduction per doubling of Manufactured Unit; \$/Doubling))
- SPS Platform Assembly Cost per SPS Platform Hardware Unit Mass (\$/kg)
- Receiver Cost per Unit Area

The following paragraphs summarize the results of diverse analytical comparisons among the FOMs above. The discussion that follows is organized into several architecture segment-focused analyses, including: (1) ETO Transport; (2) In-Space Transport; (3) SPS Platform Systems; (4) End-to-End WPT Systems; and, (5) SPS Platform Autonomy.

Earth to Orbit Transportation

*Common Specifications.*⁴² For the sake of simplification, a single SPS platform scenario was examined within this ETO analysis. This scenario involved several common assumptions regarding the specifications of the system to be launched and regarding the ETO systems themselves. One assumption was that the system to be launched was a modular SPS in which the given module size was 1,000 kg in mass. Also, all of the cases assumed that there was a common manufacturing curve for both ETO vehicle and platform/payload systems.⁴³ Finally, the initial cost per kilogram (based on the design, development test and engineering; DDT&E) for the ETO and platform systems was assumed to be lower for the ETO vehicles than for the ETO platforms. Specifically, it was assumed that the cost per kilogram for the development of ELVs was not more than \$25,000 per kilogram, that the specific cost for development of RLVs was not more than \$50,000 per

⁴² The analysis presented here was based on the rocket equation in which the mass ratio for expendable vehicles is superior to that for reusable vehicles with the same payload, and that the mass ratio for heavy lift expendable vehicles is better than for smaller expendable launch vehicles.

⁴³ The manufacturing curve (aka, the “learning curve”) used was 65%; namely, that for a doubling in the number of units manufactured, the cost per kilogram would be reduced by some 35% compared to the previous cost.

kilogram, and that the specific cost for development of SPS platform modules was not more than \$100,000 per kilogram.

In addition to the above common specifications, three different options for system lifetime were examined. The first of these was “single use” for expendable launch vehicles. The second was nominal lifetime for reusable launch vehicles, which corresponded to a use of approximately 500 flights, with “fractional expendability” of 0.02% per flight. The final option was a “long-lived” option for RLVs, which corresponded to a use of approximately 1,000 flights per airframe, with “fractional expendability” of 0.01% per flight.

Moderate-Scale SPS Pilot Plant. In this case, the ETO market option is that of launching a moderate-scale pilot plant, with a total platform launched to low Earth orbit (LEO) of approximately 400,000 kg (400 mt). Figure 7-7 presents the results of the initial analysis of the ETO options for the launch of a moderate-scale, 400 metric ton (mt) SPS pilot plant.

Figure 7-7 Launch Options for a Moderate-Scale SPS Pilot Plant (@ 400 mt)

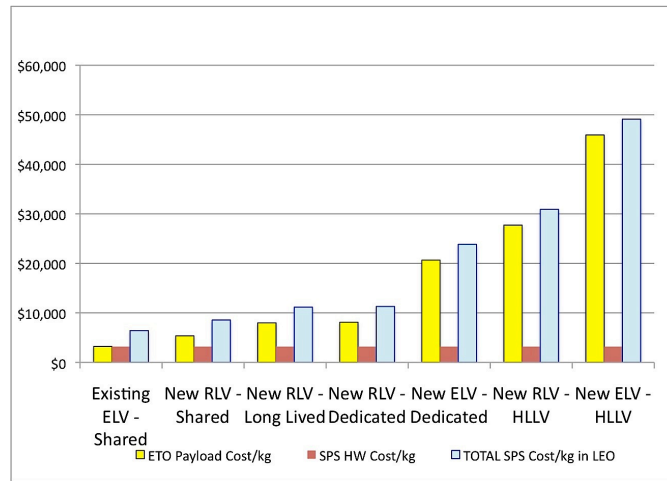

Credit: 2010 Artemis Innovation Management Solutions LLC

In the figure, the x-axis presents the seven promising ETO options under consideration; the y-axis (the vertical option) plots the estimated cost per kilogram based on several underlying assumptions.

For this market option, the best launch solution is an existing ELV system that is shared with other markets. Roughly equivalent ETO systems would include a new RLV that was shared with other markets, and a new RLV that was very long-lived. The worst ETO launch solutions for this market option were the development of a new expendable HLLV or a new reusable launch vehicle in the HLLV class. The development of a new ELV dedicated to the launch of SPS was also a more expensive option than others.

Large-Scale SPS Pilot Plant. In this case, the ETO market option is that of launching a larger-scale pilot plant, with a total platform launched to low Earth orbit (LEO) of approximately 800,000 kg (800 mt). Figure 7-8 presents the results of the initial analysis of the ETO options for the launch of larger-scale, 800 mt SPS pilot plant. In the figure, the x-axis presents the seven promising ETO options under consideration; the y-axis plots the estimated cost per kilogram based on several underlying assumptions.

Figure 7-8 Launch Options for a Larger-Scale SPS Pilot Plant (@ 800 mt)

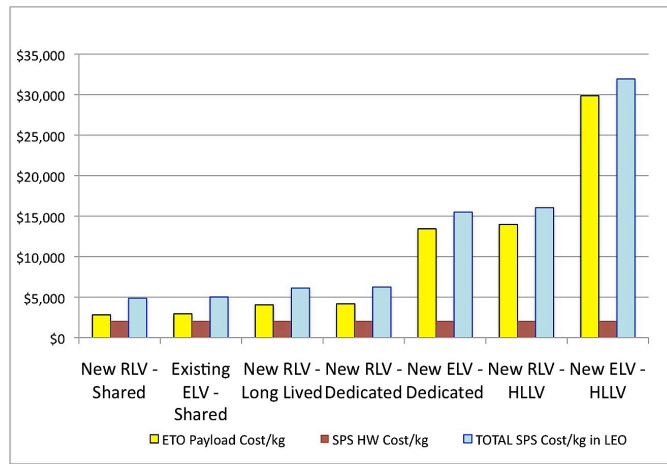

Credit: 2010 Artemis Innovation Management Solutions LLC

For this market option, the best launch solution could be either an existing ELV system that is shared with other markets or a new reusable launch vehicle (RLV). Roughly equivalent ETO systems would include a new, very long-lived RLV. In this case, there were enough launches required that even a new RLV that is dedicated only to SPS launch is a fair

solution. The worst ETO launch solutions for this market option were the development of a new expendable HLLV, the development of new reusable launch vehicle in the HLLV class and the development of a new ELV that was dedicated to SPS launch. In this case, even the most expensive launch option was still significantly cheaper than launch of the smaller SPS pilot plant.

A Single Full-Scale SPS Platform. In this case, the ETO market option is that of launching a single fully operational SPS, with a total platform launched to low Earth orbit (LEO) of approximately 12,000,000 kg (12,000 mt). Figure 7-9 presents the results of the initial analysis of the ETO options for the launch of a single full-scale operational SPS platform. In the figure, the x-axis presents the seven promising ETO options under consideration; the y-axis (the vertical option) plots the estimated cost per kilogram based on several underlying assumptions.

Figure 7-9 Launch Options for a Single Operational SPS
(Platform @ 12,000 mt)

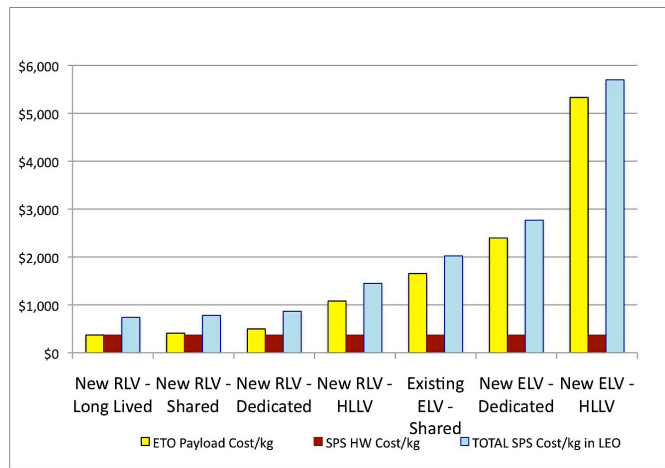

Credit: 2010 Artemis Innovation Management Solutions LLC

Even a single full-scale SPS represents a dramatic increase in the total number of launches compared to demonstration pilot plants. For this market option, the best launch solution is a new long-lived RLV system, even if it is dedicated to SPS launch. (This option gets even better if the vehicle is shared with other markets). Roughly equivalent ETO systems

would include a new RLV that was shared with other markets, and a new RLV dedicated to SPS launch that is not very long-lived. The worst ETO launch solution for this market option is clearly the development of a new expendable HLLV. At this scale of launch, expendability without high manufacturing rates is no longer at all competitive.

The development of a new RLV in the HLLV class moves up in the ranking strikingly, while moderate payload (25 mt) class ELVs are, although superior to an HLLV, becoming increasingly expensive options compared to others.

Moderate-Scale SPS Pilot Plant. In this case, the ETO market option is that of launching a four (4) full-scale SPS platforms, with a total platform launched to LEO of approximately four-times 12,000 mt (i.e., roughly 50,000 metric tons). Figure 7-10 presents the results of the initial analysis of the ETO options for the launch of four operational SPS platforms.

Figure 7-10 Launch Options for Four Operational SPS
(4 Platforms, each @ 12,000 mt)

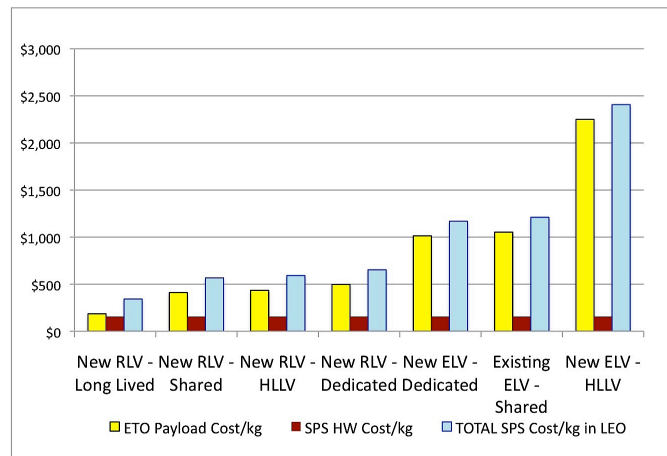

Credit: 2010 Artemis Innovation Management Solutions LLC

In the figure, the x-axis presents the seven promising ETO options under consideration; the y-axis (the vertical option) plots the estimated cost per kilogram based on several underlying assumptions.

Four full-scale SPS represent another significant increase in the total number of launches compared to a single SPS. For this market option, the

best launch solution continued to be a new long-lived RLV system dedicated to SPS launch. (As in the case above, this option gets even better if the vehicle is shared with other markets). A new RLV that was shared with other markets is a roughly equivalent option. However, now the launch rates were high enough that a heavy-lift RLV moved into third place in the comparison of options.

Expendable launch vehicles continued to improve in overall cost, but were still at a disadvantage compared to all reusable options. As in the prior case, the worst ETO launch solution for this market option continued to be the development of a new expendable HLLV. In general, the launch cost per kilogram (due to the cost of launch vehicle manufacturing) at these enormous rates continued to drop dramatically from prior cases.

In-Space Transportation

In-space transportation is another critical consideration in examining the key cost contributors to SPS economics. There are two principal technology options for in-space transportation for SPS transport: cryogenic orbital transfer vehicles (OTVs) and solar electric propulsion (SEP) OTVs.⁴⁴ Each of these can make a significant contribution to the installed cost of an SPS. The cost of launch makes a strong contribution to this cost, primarily through the cost of propellants required. Another contribution comes from the OTV hardware itself.

Some of the key cost contributors / FOMs for SPS in-space transport include:

- In-Space Transport Cost per Installed SPS Hardware unit Mass (\$/kg)
- Specific Cost of the OTV Hardware (i.e., \$/kg-OTV)
- Specific Mass of the OTV Hardware (i.e., kg-OTV/kg-SPS transported per flight)
- Number of OTV Roundtrip Flights to GEO per Year (i.e., #-OTV Flights/year)
- SPS Mass Delivered per OTV Flight to GEO (i.e., kg-SPS / OTV Flight)

⁴⁴ There are other options, of course. These include infrastructure-rich options such as space tethers and high-thrust/high-Isp options such as nuclear thermal propulsion (NTP). These alternatives should be examined in future studies.

- Number of Years in OTV Lifetime⁴⁵ (years)
- OTV Mass-Effectiveness Fractions
 - Mass of the OTV per Mass of the Fuel (i.e., kg-OTV / kg-Fuel)
 - Mass of the OTV *and* Mass of the Fuel per Payload Mass (i.e., kg-OTV+kg-Fuel/kg-PL)

A straightforward limits analysis may be performed by examining the following FOMS: the cost per kilogram for the OTV system, the number of missions per OTV, and the kilograms for the OTV system for each kilogram of SPS hardware transported. For the sake of simplification here, the following assumptions have been made:

- Cryogenic OTV: 2 kilograms of SPS Hardware per 1 kilogram of OTV Hardware
- SEP OTV: 5 kilograms of SPS Hardware per 1 kilogram of OTV Hardware

Given these assumptions, on the following page Figure 7-11 illustrates the parametric relationships for a Cryogenic OTV, and Figure 7-12 illustrates the relationships for an SEP OTV.

Three cases are examined for both types of OTV: (a) the OTV HW costs \$20,000 per kilogram; (b) the OTV HW costs \$10,000 per kilogram; and, (c) the OTV HW costs \$5,000 per kilogram.

Given the assumptions indicated above, in the case of an expendable cryogenic OTV (used only once), it is clearly impossible for the cost contribution to the SPS HW cost per deployed kilogram to be less than \$2,500 per SPS kilogram. For a reusable Cryogenic OTV, it is clear that the cost of the OTV is critical to achieving an acceptable cost per kilogram for the SPS hardware: even with 10 flights per OTV, only when the OTV hardware cost is \$5,000 per kilogram or less, is the SPS HW cost \$250 per kilogram or less. Although not shown in the figure, for 20 flights per reusable OTV, the cost performance improves and an OTV with a specific cost of \$10,000 per kilogram or less can result in SPS HW cost \$250 per kg or less.

⁴⁵ For purposes of this simplified analysis, constituent FOMS, such as fractional expendability for the OTV per flight, the probability of catastrophic failure per OTV flight, etc., are neglected.

Figure 7-11 Cryogenic OTV HW Cost Contribution to SPS HW Cost

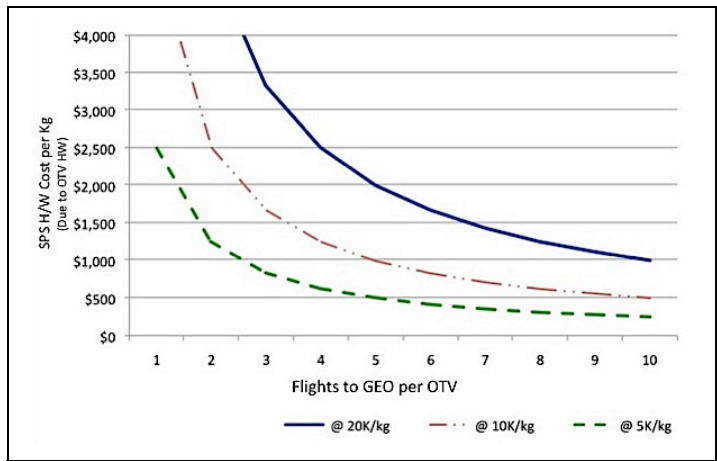

Credit: Artemis Innovation Management Solutions LLC

Figure 7-12 SEP OTV HW Cost Contributions to SPS HW Cost

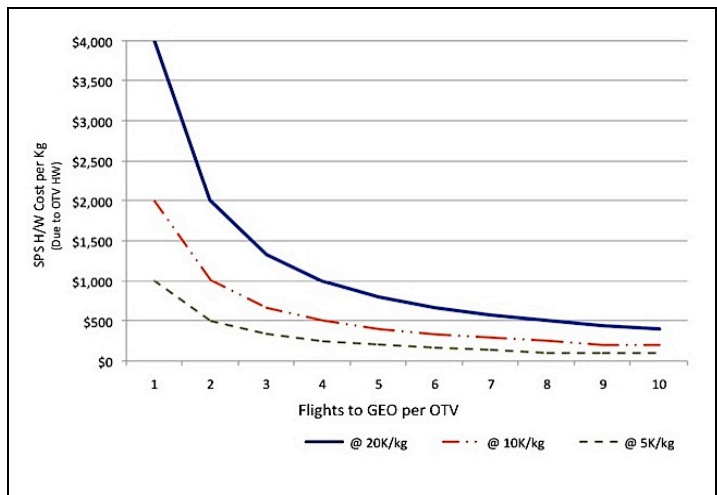

Credit: Artemis Innovation Management Solutions LLC

In the case of an expendable SEP OTV (used only once), the cost contribution to the SPS HW cost per deployed kilogram cannot be less than \$1,000 per SPS kilogram. For a reusable SEP OTV, the HW cost of the OTV is also important to achieving an acceptable cost per kilogram for the

SPS hardware. In the case of 10 flights per OTV, OTV hardware costs of up to \$20,000 or less, the SPS HW cost will be \$500 per kilogram or less. In the case of an SEP OTV of \$5,000 per kilogram or less, the cost contribution is \$100 per kilogram or less. Although not shown in the figure, for 20 flights per reusable OTV, the cost performance improves still further.

The contribution to the cost per kilowatt-hour of SPS-delivered energy due to OTV hardware costs discussed here is can be calculated based on the FOMs identified above.

SPS Platform Systems

The mass and cost of platform systems is a fundamental driver for SPS economics – more important even than ETO or in-space transportation because the mass to be transported directly affects both of these. Some of the key cost contributors / FOMs for the SPS platform itself include the following:

- Manufactured Cost per SPS Platform Hardware Unit Mass (\$/kg)
- SPS Platform Hardware Unit Mass per Unit Power Delivery Capacity (kg/kW)
- Solar Power Generation Power per unit Mass (W/kg)
- Annual Fractional Expendability per SPS Platform unit Mass (% of SPS Mass /Year)
- Number of Modules per SPS (Number)
- SPS Hardware Manufacturing Learning Curve (H/W cost reduction per doubling of Manufactured Unit; \$/Doubling))
- SPS Platform Assembly Cost per SPS Platform Hardware Unit Mass (\$/kg)

As in the case of the cost contribution due to OTV hardware costs discussed above, the contribution to the cost per kilowatt-hour due to the SPS hardware manufactured cost is a straightforward calculation based on the FOMs identified above.

End-to-End WPT Systems

The mass and cost of platform systems is a fundamental driver for SPS economics – more important even than ETO or in-space transportation because the mass to be transported directly affects both of these. Some of

the key cost contributors / FOMs for the SPS platform itself include the following:

- Delivered Power Cost per Unit Mass of the SPS Platform (\$/kg)
- Delivered Power Cost per Unit Power Delivered on Earth (\$/kW-hour)
- SPS Platform Hardware Unit Mass per Unit Power Delivery Capacity (kg/kW)

Integration of Ground Power and Space Solar Power

The successful integration of ground power infrastructures and space solar power systems is another critical issue that must be successfully resolved for SPS to eventually be successfully deployed. There are several important questions; two of these are: (1) the cost per unit area of the WPT receiver (and the impact of this figure of merit on SPS platform size), and (2) the relationship between ground solar power and space solar power.

WPT Receiver Cost per Unit Area. A key question for SPS architectures is the cost per unit area of the WPT receiver system (whether a Rectenna in the case of microwave power, a tailored PV array in the case of laser power transmission, or radiant energy-thermal receivers in the case of direct synthetic fuel production). The issue is simply stated: what is the likely cost contribution due to the ground receiver to total energy cost, versus the cost due to the installed SPS itself? There are several reasons that this question is important.

First and foremost, the cost due to the ground receiver is important for the basic economic feasibility of a full-scale SPS serving baseload commercial markets. In general, this question is easily resolved: the cost per watt of delivered power (based on detailed design studies in the 1970s) can be expected to be approximately \$3/watt or less per watt generated.⁴⁶ Assuming that the energy density of the WPT transmission at Earth is approximately 100 watt/meter², and the conversion efficiency is about 80%-85%, then the cost contribution due to the Receiver will be roughly \$325/meter². In this case, the cost of the ground receiver makes a moderate contribution to the total cost of energy from the system.

⁴⁶ The actual cost per watt projected in the 1970s studies was about \$1/watt; projecting via standard inflation tables to 2010, yields a cost of roughly \$3/watt for the same study results.

If this projected cost can be reduced, then the resulting cost contribution will drop to a minimal, or even a trivial component of the total cost of SPS-delivered energy. Similarly, in the case of a full-scale SPS serving so-called “premium niche markets”, the cost of the ground receiver is important, but much less so than in the case of the traditional baseload market described above due to the much higher price that may be achieved.

Another consideration for a full-scale SPS system is the cost of building multiple receivers for a single SPS. In general, this strategy is highly promising from the standpoint of market-oriented energy delivery in that it allows great utilization of fixed capacity vis-à-vis the SPS itself, and it enables the SPS operator to deliver power to more profitable (higher priced) markets during the course of a single day, week, or season. However, the concept depends on relatively low cost receivers being achievable.

And finally, if the cost of the ground receiver system is high then it could make an unacceptably large percentage contribution to the cost of an SPS pilot plant demonstration. This implies that assuring that the cost of the ground receiver can be reduced to not more than 1970s era cost estimates will be an important element of SPS and SSP related R&D activities.

Table 7-7 summarizes qualitatively the various market options for SPS energy in the context of alternative costs per unit area of the receiver.

Relationship Between Ground and Space Solar Power.^{xlviii} A fundamental challenge to future increased use of more than roughly 10% or so renewable power sources in the electrical supply is that of intermittency: the two leading candidates for new green energy – wind and solar – do not deliver power constantly. As a result, typically renewable energy deployments require maintenance or deployment of additional fossil fuel power plants to assure continuity of power when the sun is not available or the wind is not blowing. This traditional deployment practice becomes highly problematic if renewable power capacities are increased above a certain level (as noted above).

This will be especially true if the global production of critical fossil fuels hit a peak level during the course of the next several decades and renewable power systems must provide the full power required. Figure 7-13 below illustrates this point with notional data, in which the overall electrical load requirement for is compared to the power capacity on an hour-by-hour

basis that might be delivered by an integrated ground solar and wind based power system.⁴⁷

Detailed background figures that underlie the summary Figure 7-13 are provided in Appendix H. In this figure, the renewable energy line is a composite of assumed wind and solar power components, which is contrasted with the regular daily load demand

Table 7-7 Qualitative Assessment of the Expected Impact of Receiver Cost per Unit Area on the Viability of Various SPS Market Options

SPS Market Option vs. Receiver Cost/m ²	Receiver Unit Cost: LOW per Unit Area	Receiver Unit Cost: MODERATE per U.A.	Receiver Unit Cost: HIGH per Unit Area
Full-Scale SPS & Premium Niche Market	Receiver is a Trivial Fraction of \$/kWh	Receiver is a Minimal Fraction of \$/kWh	Receiver is a Moderate Fraction of \$/kWh
Full-Scale SPS & Commercial Baseload	Receiver is a Minimal Fraction of \$/kWh	Receiver is a Moderate Fraction of \$/kWh	Receiver is a Moderate Fraction of \$/kWh
Full-Scale SPS & Multiple Receivers	Receiver is a Moderate Fraction of \$/kWh	Receiver is a Moderate Fraction of \$/kWh	Receiver is a High Fraction of \$/kWh
Pilot-Scale SPS & Premium Niche Market	Receiver is a Moderate Fraction of \$/kWh	Receiver is a High Fraction of \$/kWh	Receiver is a High Fraction of \$/kWh

The key issue illustrated in Figure 7-13 is that the power delivered from even a significantly oversized wind and solar power infrastructure can fall well below the power requirements of a given locality.

However, prospective SPS technologies that have emerged during the past 20-20 years may enable a more dynamic and flexible integration of ground-based renewable energy sources and space solar power – particularly the possibility of rapidly re-targeting the power transmission from an SPS from one location to another. (For example, an electrically-steered RF beam from a modular sandwich-type SPS could allow rapid repositioning of the power transmission from location on Earth to another.)

⁴⁷ The graphic shown here is only notional; however, it is derived from data presented by Mr. John Strickland at the SPS 2009 International Symposium held at the Ontario Science Center in Toronto, Canada.

Figure 7-13 Comparison of Notional Renewable Power Generation and Load Requirements

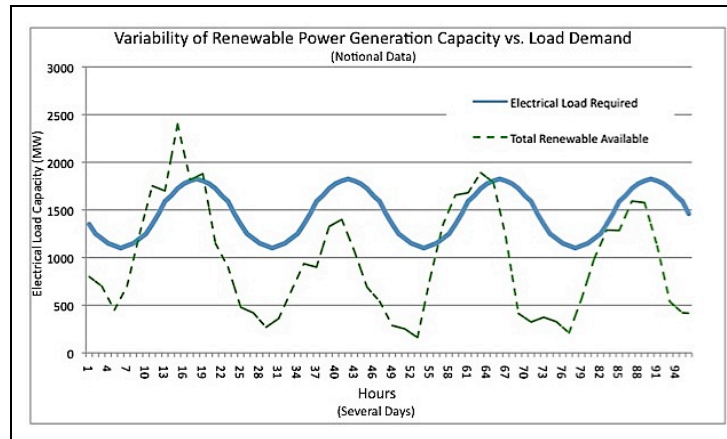

Credit: Artemis Innovation Management Solutions LLC (2011)

It may well prove that an optimal combination will involve the integration of intermittent ground-based renewable energy systems and continuously available space-based solar power.

SPS ISAAC Robotics and Systems Autonomy

There are several important and interrelated considerations related to robotics, in-space assembly and construction (ISAAC) and autonomy for space solar power (SSP) systems. These include the following key systems-technology figures of merit:

- Unit-time required for ISAAC operations per unit-mass of the SPS platform
- Labor-hours per unit-mass of the SPS platform (i.e., the inverse of the degree of autonomy of the system)
- Unit-mass required for ISAAC systems per unit-mass of the SPS platform

A closely interrelated consideration is that of the probability of failure and/or the mean time between failure (MTBF) for the SPS system at various levels, from the lowest independent module through independent major assemblies of modules, to the full SPS platform (including potential single points of failure that may exist at the platform level). In this context, the degree of systems modularity (DSM) is a key driver of both ISAAC

requirements and the anticipated MTBF at the platform level. Figure 7-14 illustrates this interactive trade space of systems design issues and options.

The longer the time required for each assembly operation, and the greater the number of assembly steps to be achieved (i.e., the larger the number of modules), then the longer the total time that will be required for SSP platform deployment. Similarly, the shorter the MTBF at the module level and the longer the time required for each assembly operation, then the greater the total annual cost for operations and maintenance (O&M)—setting aside considerations of the cost of each module.

Based on the details of the SPS architecture, there may also be single points of failure (SPF) inherent in the concept; these clearly require special attention. For example, in the case of the updated 1979 SPS Reference System, there are several SPFs.

Figure 7-14 In-Space Assembly & Construction / Autonomy Trade Space

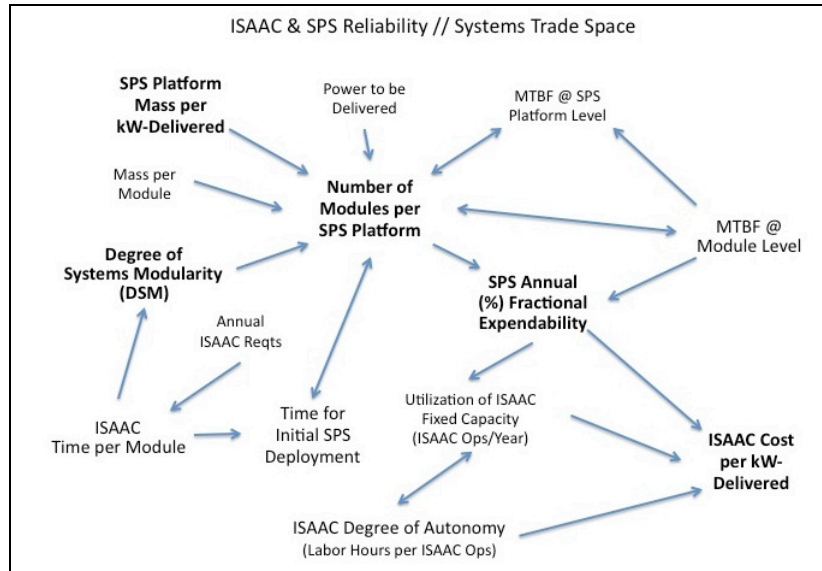

Source: Artemis Innovation Management Solutions LLC © 2010

One such location for single points of failure is found in the large rotating gimbals between the PV arrays and the WPT transmitter; here there are a total of three such points: (1) the extremely large diameter gimbaling system between the PV array structure and the yoke holding the transmitter,

and (2) the twin large diameter gimbal systems between the yoke structure and the WPT transmitter itself. Each of these interfaces entails several complex system elements, including high-voltage conductors, mechanical rotary couplers, and possible momentum control systems (flywheels). All three of these must function successfully or the entire SPOS must be shut down to effect repairs.

In summary, the degree of autonomy of the SPS platform systems is an important driver for the economics of the very long-lived SPS operations. Some of the key cost contributors / FOMs for the autonomy of the SPS platform itself include the following:

- Annual Labor Hours per unit SPS Hardware Mass (Hrs/kg-year)
- SPS Platform Assembly Cost per SPS Platform Hardware Unit Mass (\$/kg)

7.4 SSP “Zones of Interest”

Integrated / end-to-end systems analysis, high-level goals and objectives for future SSP technology R&D can be identified. The limits analysis approach can result in diagrams of one key parameter versus another that can be used to conveniently visualize high-level relationships among the key figures of merit. For example, a FOM such as “labor hours per kilogram of platform mass” may be mapped as an independent variable (e.g., on the x-axis) against the FOM “cost per kilowatt-hour” as a dependent variable (e.g., on the y-axis). Within this type of figure, it is possible to identify upper and lower limits for each variable – for example, the lowest feasible “labor hours per kilogram” and the highest economically-viable “cost per kilowatt hour” may be used to establish a “zone of interest” for SSP and related technology R&D. The development of these parametrically derived “zones of interest” should be an objective of future end-to-end SPS systems analysis studies.

Based on the results of the IAA SSP study, it is clear that there are three critical figures of merit for SSP technology R&D. The first of these is the SPS platform mass per unit power delivered to Earth. For this figure of merit, the zone of interest is approximately 1-5 kilograms per kilowatt received at Earth. The second critical FOM is the cost per kilogram of the installed SPS platform. For this figure of merit, the zone of interest is approximately \$1,000-\$5,000 per kilogram of installed SPS platform. Finally, a third systems-level FOM is the expected lifetime of the SPS

platform elements (i.e., how long each kilogram of SPS will be operational and delivering power to Earth). In the case of this final FOM, the zone of interest is roughly from 10 years to 20 years.

Obviously, the several zones of interest are interrelated: the lower the platform mass, the less important will be the installed cost per kilogram. The higher the overall cost per kilogram (mass times cost per kilogram), the more important will be the lifetime of the SPS platform mass in orbit. For example, for a mass of some 3 kilograms per kilowatt of power received on Earth, an installed SPS platform unit cost of \$3,000 per kilogram (\$, US), and with a platform lifetime of 20 years, then the cost per energy delivered by the solar power satellite will be roughly 5¢ per kilowatt-hour – well within the competitive range of commercial baseload power in 2010. SSP technology R&D efforts must be targeted on achieving the zones of interest for the key figures of merit that will enable economically viable solar power satellites.

7.5 R&D Goals and Objectives

Based on the results of the parametric analysis above, a number of critical goals and objectives for SSP and related technology R&D can be established. These range from very high-level goals at the systems-technology level to more focused objectives at the component-technology level. The high-level, critical SSP technology R&D goals and objectives may be expressed in terms of three figures of merit:

- For a solar power satellite, the specific mass per unit power delivered on Earth should be roughly in the range: 1-5 kilograms per kilowatt delivered;
- For SPS Platforms, the platform installed cost should be in the range: \$1,000-\$3,000 per kilogram on orbit; and,
- The expected lifetime of each kilogram of SPS platform mass should be in the range of 10-30 years or greater.

At a qualitative level, these R&D goals and objectives may be further articulated in greater detail as follows:

- For SPS Platforms (including the WPT end-to-end system)⁴⁸
 - Reduced Cost of SPS System Hardware, to below \$400-\$800 per SPS-kg
 - Improved End-to-End SPS WPT Efficiency, to greater than 60%
 - In particular, for large-scale, baseload commercial power markets
 - Improved overall SPS Platform Specific Power⁴⁹, to greater than 300-600 Watts per SPS-kg
 - Lower Cost for SPS Platform Operations, to below \$200-\$400 per SPS-kg year.
- For SPS Supporting Systems and Infrastructure
 - Reduced Cost of ETO Transport, to below \$300-\$500 per SPS-kg
 - Reduced Cost of IST Transport, to below \$400-\$600 per SPS-kg
 - Low Cost for SPS In-Space Operations, to below \$200-\$400 per SPS-kg year.

Each of the above R&D goals comprises (as has been discussed elsewhere) a variety of interrelated technical and economical objectives. The detailed quantitative formulation of the key goals and objectives (including for each system / sub-system element both “threshold” and “goal” objectives) should be an objective of future end-to-end SPS systems analysis studies.

7.6 Analysis & Evaluation of Selected Types of SPS

There are clear distinctions that can be drawn among the principal candidate SPS system concepts and related supporting systems, described in detail in Chapters 2 and 3. The following sections summarize the similarities and the differences among the SPS concepts that have been considered.

SPS Type I: 1979 SPS Reference and Related Concepts

Advantages. There have been numerous advances in relevant subsystem technologies that are appropriate for SPS concepts of the 1979

⁴⁸ R&D goals stated here (such as End-to-End WPT efficiency) are for large-scale, baseload commercial power markets; R&D goals may be lower / higher for other markets, such as smaller, premium niche markets.

⁴⁹ This is measured from the power output from the wireless power transmission system.

Reference System type. The most significant advantage is the potential to incorporate exceptionally low specific mass, thin-film PV arrays in the platform. Moreover, in this SPS Type, all major technologies may be independently matured and then later integrated (e.g., WPT and SPG are fully separated.) The use of this technology approach would result in easier technology maturation and demonstration than other types of SPS concept.

Disadvantages. In terms of the Technology Readiness and Risk Assessment for SPS Type I, there are a number of inherent technical challenges that must be overcome that are greater than those for other types of concepts. For example, in order to take best advantage of the low mass PV, advanced technology for PMAD systems is needed such as high-temperature superconductor (HTS) PMAD systems. In addition, for an operational system the “Cost to First Power” for a Type I SPS is likely to be higher than for other SPS Types due to the very substantial fixed infrastructure requirements – including, but not limited to the need for larger, specially developed ETO systems, large-scale LEO infrastructure and extensive GEO ISAAC infrastructure.

SPS Type II: Laser SPS Concepts

Advantages. The most obvious advantage of laser-type SPS concepts is the exceptionally high frequency (short wavelength) of the beam and the correspondingly small transmitter and receiver apertures that are thereby enabled. As a result, the system “Cost to First Power” for an operational system element is lower for a laser type SPS than for any other case. Also, the Type II laser SPS (like the Type III) lends itself to modular, self-assembling platform concepts and a significantly reduced requirement for *a priori* for in-space infrastructure for ISAAC.

Disadvantages. A number of critical technology advances are required to approach economic viability for a Type II SPS using laser WPT, resulting in a more challenging set of lower TRL technology R&D goals, and a less favorable technology readiness and risk assessment than for the Type III SPS.

Special Considerations. From the standpoint of the receiver and transmitter optics, the economically optimum design option for near-visible laser WPT SPS involves a small diameter receiver with multiple-sun energy densities per square meter and a relatively large telescope aperture for the beam expander on the platform. However, this approach is not the best for

a number of other design considerations. For example, thermal considerations drive platform designs toward smaller individual laser diode arrays. Also, safety and policy considerations related to potential weaponization of the SPS system, much smaller on-orbit apertures militate in favor of smaller apertures. These factors, coupled with others, resulted in the decision to baseline much lower beam energy densities were in this IAA study.

SPS Type III: Sandwich-Type SPS Concepts

Advantages. The Type III modular Sandwich Type SPS (like the Type II) lends itself to modular, self-assembling platform concepts and a significantly reduced requirement for *a priori* for in-space infrastructure for ISAAC. The nature of the concept implies that technology maturation and demonstration will be relatively straightforward within individual modular elements – primarily of the main SPG/PMAD/WPT structure lending themselves to affordable R&D efforts.

Disadvantages. An important disadvantage of the Sandwich SPS concept is the requirement for a novel solution for the transmitter / PV module thermal management system (TMS). Failing to find a thermal management system solution, an architecture level solution might involve limiting the peak power transmitted per square meter on the array – thus requiring either a departure from a 10-to-1 taper Gaussian distribution across the transmitter or a drastic reduction in the total power transmitted.

Special Considerations. The capability of the electrically beam steered sandwich RF transmitter could enable new types of markets and the potential to serve multiple markets simultaneously (or nearly so). If the power from a single SPS were shared among multiple receivers, then a larger aperture transmitter (and proportionately smaller receivers) could become viable without exceeding RF energy intensity guidelines at any single receiver site.

Summary Assessment of SPS System Concepts

Based on the preceding analyses, the IAA formulated a summary – albeit highly qualitative – assessment of the three SPS concept types. This assessment involved two basic considerations: (1) a range of technical criteria (reflecting the policy issues, technology assessment, and systems analyses presented in the preceding chapters), and (2) evaluation versus the

four global Scenarios for how energy/environmental considerations may evolve during the remainder of this century. The following section summarizes that overall evaluation.

Evaluation Process. The three SPS Types were ranked in terms of the following technical criteria:

- Criteria 1. Expected Operational system “Cost to First Power”
- Criteria 2. Life Cycle Cost / Economics (Overall Across Scenarios)
- Criteria 3. Technology Readiness and Risk Assessment
- Criteria 4. Ease of Technology Maturation / Demonstration
- Criteria 5. Scope / Difficulty of Potential Policy Issues
- Criteria 6. Prospective Variety and Benefits for non-SPS Applications

The rating / scores used to evaluate the concepts in terms of technology technical criteria were as follows:

- Rating “2” – SPS System Type has significant positive aspects regarding the criteria
- Rating “1” – SPS System Type has some positive aspects regarding the criteria
- Rating “0” – SPS System Type is neutral regarding the criteria strong relevance to scenario
- Rating “-1” – SPS System Type has some negative aspects regarding the criteria
- Rating “-2” – SPS System Type has significant negative aspects regarding the criteria

Overall, the higher the total rating of the SPS concept, the more likely that the concept could be developed, deployed and operated successfully. However, given the high level of uncertainty at present, this evaluation should be regarded as strictly preliminary. As noted elsewhere, more in-depth end-to-end systems analysis studies (supported by relevant technology R&D and demonstrations) are needed.

The assessment of the three SPS system types against the four global scenarios was developed using the following ratings: (a) Rating “0” – SPS System Type has little or no relevance to scenario; (b) Rating “1” – SPS System Type has some to moderate relevance to scenario; and, (c) Rating “2” – SPS System Type has strong relevance to scenario.

Evaluation Results. The overall results of the evaluation are presented below. Table 7-8 summarizes a technical comparison of the SPS system concepts examined, while Table 7-9 provides a comparison of the concepts in terms of the Global Scenarios.

Table 7-8 Summary Comparison of SPS Concepts – Technical Criteria⁵⁰

		SPS Type I	SPS Type II	SPS Type III
TECHNICAL CRITERIA		"RF Classic"	Modular Electric Laser	RF Modular Sandwich
1	Cost to First Power	-2	+2	+1
2	Life Cycle Cost / Economic Prospects	+2	0	+2
3	Technology Readiness / Risk	-1	+1	+2
4	Expected Ease of Tech. Maturation	0	+1	+2
5	Policy Issues (Scope Difficulty)	-1	-2	-1
6	Non-SPS Applications (Variety/Benefit)	0	+1	+1
Summary Assessment		-2	+3	+7

Table 7-9 Summary Comparison of SPS Concepts - Evaluation vs Scenarios

		SPS Type I	SPS Type II	SPS Type III
SCENARIO ASSESSMENT		"RF Classic"	Modular Electric Laser	RF Modular Sandwich
Alpha	"Business as Usual Works Out"	0	2	2
Beta	"The Frog Gets Cooked"	2	2	2
Gamma	"Fossil Fuels Run Out"	2	2	2
Delta	"Green Policies Work"	1	1	2
Summary Assessment		5	7	8

An Overall Evaluation Criteria (OEC) was developed to sum up potential figures of merit for each of the SPS system concept types. Since there were two scoring processes, one for the Technical Criteria and another for the various Scenarios, two different OEC scores were

⁵⁰ In this assessment, the SPS Type comprises not only the solar power satellite platform, but also the supporting infrastructure(s) required for the platform.

determined respectively. For the Technical Criteria scoring, the weightings of the technical criteria were the same. This would show robustness of the SPS concept type amongst all the metrics. A similar approach was taken for the Scenario ranking, showing robustness amongst various scenarios. Figure 7-15 shows the OEC for each SPS system concept type in terms of the two different ranking criteria.

7.7 Summary

Based on the very high-level comparative analysis among the three Types of SPS examined by the current IAA study (and for the scenarios / market cases defined), it appears that there are clear advantages for more modular, higher end-to-end efficiency systems concepts – particularly for large-scale commercial baseload power. (Figure 7-15 provides a summary diagram of the evaluation.) And, the highly modular microwave WPT sandwich SPS concept appears the most attractive overall.

Figure 7-15 Integrated Results of SPS Concept Evaluation

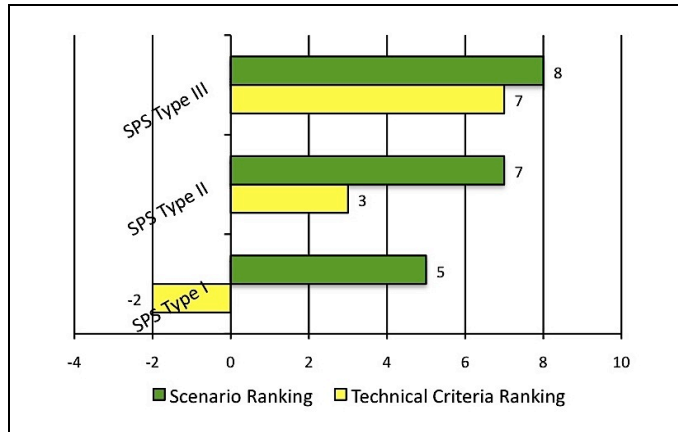

However, it is clear that additional, more analytically rigorous systems analysis studies are needed to better characterize the complex systems-technology-market issues that space solar power entails.

CHAPTER 8

AN INTERNATIONAL ROADMAP FOR SPACE SOLAR POWER

One of the principal objectives of the IAA study was – if appropriate – the “*formulation of a strategic approach to realizing the potential of energy from space—and one or more technical / programmatic roadmaps implementing this strategy*”. {Reference: SG8.} Based on the study results, it was the consensus of the IAA that an international roadmap for SSP/SPS was appropriate.

This chapter synthesizes the IAA study’s high-level roadmap for space solar power, detailing a prospective path forward for the international space and energy community.

8.1 Roadmap Approach

There were several ground rules used in framing the IAA SSP roadmap. First, the detailed milestones included in the roadmap do not depend on the specific budgets invested by government or commercial organizations. Second, the roadmap produced cannot be schedule- and/or calendar-specific (since both of these are dependent on budgets). Rather, the IAA roadmap is strategic in character – providing a coherent and flexible framework for a wide range of prospective government, industry and academic institution activities to advance space solar power. However, the roadmap does indicate roughly what could be accomplished in terms of schedule and technology maturity – depending on budgets and programs.

Moreover, the roadmap recognizes that the business model by which SPS may be developed is by no means fixed. Development options include: (1) a major government project (including both national and international components); (2) public / private partnerships (potentially involving multiple governments); and, (3) private enterprise venture.^{xlix} Novel approaches, such as “Prize Challenges” might also play a role. The roadmap is entirely flexible in terms of which of these development mechanisms might ultimately be employed – or even (which is most likely) different aspects of the roadmap follow different development organizational approaches. (For example, the SPS might be developed through a public / private partnership, while the launch system(s) used might be either private or government provided.)

Finally, the SSP road map reflects the belief of the IAA that the technology needed is not mature at present. Rather, several iterative stages of systems study and focused technology R&D will be necessary to enable the deployment of economically viable SPS.

8.2 Preliminary International Roadmap for Solar Energy from Space

Figure 8-1 below presents the strategic roadmap for space solar power that summarizes the results of the IAA study. The costs, and price of energy delivered from SSP systems have not yet been established; however, these costs and the economics of resulting SPS will clearly depend on both the engineering of the SPS platform and its supporting systems, and the markets that such systems seek to serve.

Figure 8-1 An International Roadmap for Space Solar Power

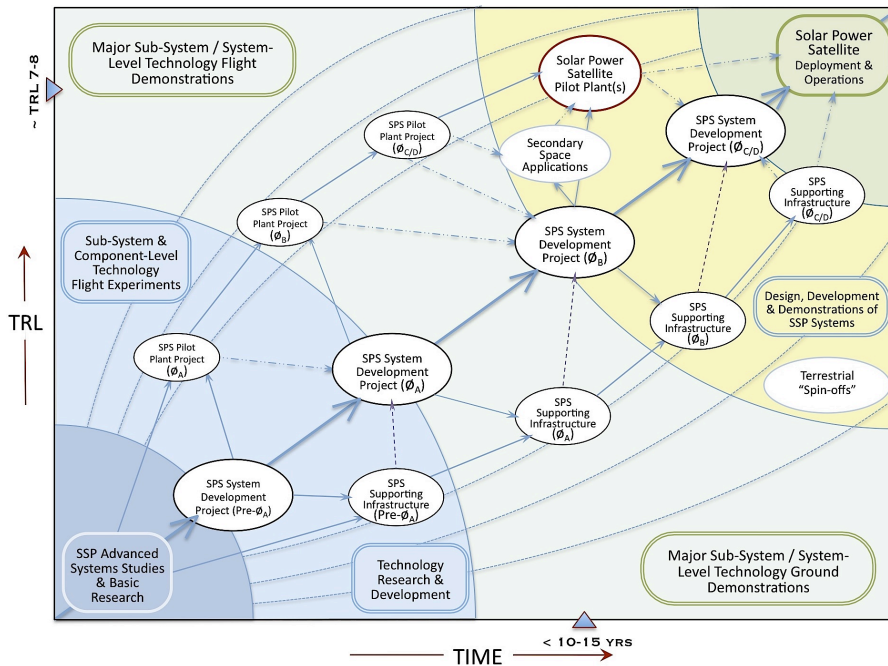

Credit: Figure Provided by Artemis Innovation Management Solutions LLC

As a result of the above, the proposed international SSP roadmap for provides for self-evident technical accomplishments and for periodic and

timely progress in the development of energy markets and commercially viable applications of key SSP technologies and systems.

There are several key aspects of the proposed roadmap. First, it is the consensus of the IAA that this roadmap could be accomplished – through the systems-level pilot plant demonstration – in roughly 10-15 years. (Note that this is not an exact forecast; i.e., achieving the roadmap, through a large-scale pilot plant will most likely not require 20-30 years or more, nor less than 5-7 years.) Also, realizing space solar power will require several major tracks to be pursued in parallel, including:

- (1) The primary path: development of solar power satellite platform technologies and systems;
- (2) Design, development and deployment of a large-scale SPS pilot plant; and,
- (3) Development of key SPS-supporting infrastructures (e.g., in-space transportation, in-space assembly, etc.).

Finally, the roadmap comprises several types of activities, organized roughly according to increasing technology readiness levels; these include:

- SSP Advanced Systems Studies and Basic Technology Research;
- SSP-Relevant Technology Research and Development;
- SSP Sub-System & Component-Level Technology Flight Experiments;
- Major Sub-System / System-Level Technology Demonstrations
 - Ground Demonstrations
 - Flight Demonstrations
- Design, Development & Demonstrations of SSP Systems
 - Including SPS Pilot Plants, Supporting Infrastructures, Secondary Space Applications, and Terrestrial Spin-Offs
- Solar Power Satellite Development, Deployment and Operations

8.3 Studies and Basic Technology Research

Given the broad scope of systems and infrastructure that SSP represents, naturally enough a similarly wide range of studies and basic technology research are needed – involving diverse areas. (Many of the specific areas in which R&D is needed are identified in earlier Chapters of this Report.) In addition, however, real progress toward an initial operational SPS system could be undertaken in the immediate future –

perhaps in the form of a sub-scale pilot plant that could profitably serve premium niche markets.

For example, experiments have been performed in recent years that have validated several of the novel technologies (e.g., retro-directive phase control) that are needed to enable the hyper-modular sandwich SPS architectural approach. One such test was performed over a distance of 148 km in the U.S. state of Hawaii in Spring 2008.¹ Figure 8-2 presents a photograph taken of the solar-powered microwave power transmission test equipment on location on the crest of Haleakala on the island of Maui in May 2008. (This test was sponsored by Discovery Communications, Inc., and was performed by an international team comprising from Japan, Kobe University; and from the US, Texas A&M University, Managed Energy Technologies LLC, and Dr. Neville Marzwell (formerly of the NASA Jet Propulsion Laboratory).

Figure 8-2 Solar Powered WPT Equipment in Hawaii (May 2008)



Credit: N. Kaya; Presentation at SPS 2009, in Toronto, Canada

The ideal case for ongoing advanced technology research would be one in which there was general agreement regarding one or two basic architectures and systems design concepts for space solar power into which ongoing component-level improvements were to be later incorporated. Examples of such relevant areas for component technology R&D include: (1) FET amplifiers (for sandwich type concepts); (2) thermal management systems (for modular laser type concepts); or (3) high-voltage PMAD systems (for “Microwave Classic” type SPS concepts). The identification of

such a higher-level framework for R&D should be a key goal for SPS/SSP systems analysis and design studies.

8.4 Technology Flight Experiments and R&D

In a number of cases, only the space environment can allow the necessary experiments and tests to be conducted to mature a particular technology. In the case of space solar power R&D, there are a number of possible technology flight experiments (TFEs) that may be needed to verify component and system performance, and to validate systems integration design choices. (Systems level technology flight demonstrations are discussed later.) Some of the most important prospective TFEs include the following:

- Wireless Power Transmission Experiments;
- Large Space Structures and In-Space Assembly Experiments; and,
- SPS Platform Component Experiments.

Wireless Power Transmission TFEs

Although many of the fundamental aspects of the engineering of WPT can be developed and demonstrated through ground-based and airborne technology experiments, there are a range of specific TFE options that will require the use of the space environment. Tests of wireless power transmission in space could include:

- Ground-to-Space WPT Tests
- Space-to-space WPT Tests
- Space-to-Ground WPT Tests / LEO
- Space-to-Ground WPT tests / GEO

Such TFEs result in validation of technology readiness levels in the range of TRL 4 to 5. (See Appendix C.) In addition, these experiments can contribute to better understanding of the interactions between the WPT transmission and the environment – in space and in the atmosphere. Tests of microwave power transmission at various power levels from LEO to the ground, for example, appear very useful in further evaluating the interactions of the WPT beam with the ionosphere.

During the past 40 years, a variety of lower TRL, SPS-relevant technology flight experiments and ground technology demonstrations have been performed – particularly in the field of wireless power transmission.

The earliest of these involved specific component technologies that may no longer be fully relevant to eventual SPS realization, while other components (particularly involving rectennas) have been successfully demonstrated repeatedly over the years. Appendix G provides a selection of some of the more significant WPT tests – on the ground and in-space – that have been performed.

A variety of additional technology developments / demonstrations are also ongoing in 2010. These include development of microwave and laser WPT ground tests by USEF / JAXA in Japan, and development of a sandwich panel test article by the U.S. Naval Research Laboratory; and laser power transmission studies at EADS Astrium in Europe.

Large Space Structures and In-Space Assembly TFEs

The deployment and/or assembly of very large space structures in a zero gravity space environment is one of the most obvious areas in which future technology flight experiments could prove invaluable. In recent years, one concept that has been discussed is that of using a large lightweight mesh as a scaffold for the in-space assembly of the transmitter/PV array of an SPS of the Sandwich type. Initial flight experiments have been conducted using a sounding rocket to launch such as test system (using a simple rotational mesh deployment scheme). Other deployment approaches, such as inflatable structures to which the mesh might be attached also appear promising.

A key requirement in this case will be to assure that structural concepts and in-space assembly technologies (e.g., robotics) are researched and tested in concert. Large space structures and/or in-space assembly TFEs would result in validation of technology readiness levels in the range of TRL 4 to 5. (See Appendix C.)

SPS Platform Component TFEs

There are a range of SPS platform components that would be good candidates for technology flight experiments (TFEs). The objectives of such tests would include (a) verifying the performance of key components (e.g., solar cells, PMAD system elements, electronics, communications systems elements) in the space environment; (b) verification of key mechanisms, actuators and related tribology for key SPS components; and, (c) lifetime testing and related servicing and maintenance demonstrations for the full range of prospective SPS components and subsystems. Such TFEs would

result in validation of technology readiness levels in the range of TRL 4 to 5. (See Appendix C.)

8.5 Systems-Level Technology Demonstrations and Flight Demos

There are several different options in the pathway to an operational SPS involving systems-level demonstrations. One option is that of systems-level technology demonstrations of various key elements of particular solar power satellite architectures in an appropriate environment on Earth. Such demonstrations might involve point-to-point wireless power transmission using WPT systems to be later demonstrated in space, in-space assembly and construction supporting system elements, and others. Another option for a systems-level technology demonstration might involve the assembly and operation of a sub-scale SPS platform in LEO that embodies most or all of the functional aspects of an SPS pilot plant or operational SPS system. Such TFDs would result in validation of technology readiness levels in the range of TRL 6 to 7 (See Appendix C.)

8.6 Pilot Plant(s) and Space Applications

In cases where the overall R&D and conceptual “riskiness” of a new space system is judged to be low, full-scale system development may proceed once individual technologies are validated at TRL 5 (or TRL 6 at most). However, in the case of a novel and ambitious new system – such as space solar power systems – a higher level of technology demonstration will almost certainly be required. There are two interrelated, but distinct aspects of the next-but-last stage in the proposed roadmap for SSP: (1) development, deployment and operation of both SPS pilot plants (perhaps at sub-scale, but capable of being scaled up), and (2) development of space applications of SSP technologies and systems at the subscale.

SPS Pilot Plant

In order to qualify as a true “pilot plant” – rather than a technology experiment or demonstration – it is crucial for the system being demonstrated to be at a sufficient scale so as to allow testing and validation of essentially all aspects of the end-to-end challenges of building, launching, deploying, assembling and operating a solar power satellite. A typical rule of thumb might be that an SPS Pilot Plant should be capable of generating a wireless power transmission approximately 10% of the power level of a

full-scale SPS using the same suite of technologies, but certainly not less than 1% of that power level.

If an SPS pilot plant is developed, it should also be capable of being used to deliver power operationally to large-scale receivers on Earth positioned in locations that are relevant to, if not the same as anticipated subsequent market locations.

The design and development of an SPS pilot plant would be itself a tremendous undertaking. The purpose of which would be to validate system designs and key technologies before committing to full SPS development. In fact, the SPS concept is sufficiently transformational and entails enough technical uncertainties at the systems level such that major in-space demonstrations will be necessary to establish technical feasibility, engineering characteristics and economical viability before any organization is likely to proceed with full-scale development.

The likely investment in technology maturation, hardware development and system deployment for a very low-cost, highly reusable space transportation (HRST) system will require some 10s of billions of dollars (\$, US). If the SPS concept is the sole – or even a significant – market justification for such a development, then it is likely that a large-scale, pilot plant type demonstration of the SPS to be launched will be required prior to a government and/or commercial commitment to fielding HRST systems or supporting infrastructure. In-space systems and infrastructures that will support SPS deployment, assembly, servicing, etc. will be intimately related to the detailed designs and characteristics of the SPS platform, and to the design of support ETO systems. Such in-space systems will likely need to be developed and demonstrated in tandem with, if not prior to, the implementation of an SPS pilot plant demonstration. Such systems level in-space demonstrations would result in validation of technology readiness levels in the range of TRL 7 and higher. (See Appendix E.)

SSP Space Applications

An important aspect of SSP technology development – and eventual economic viability of SPS – is that of finding interim milestones and applications for the technologies, components, and systems to be developed. This concept is in-line with the phrase of “pay as you go” – i.e., the idea that SSP development should entail meaningful, and hopefully profitable applications long before solar power satellites begin delivering power to terrestrial markets.

As noted elsewhere, there are a variety of prospective space systems applications for (1) SPS platform subsystems / systems; (2) in-space transportation systems; (3) in-space infrastructures; (4) ETO vehicles; and, others. In particular, there are a variety of potential space applications of SSP technology (see Chapter 5, Section 5.3) that are consistent with the power levels that would typically characterize a “pilot plant” for a full scale operational SPS.

8.7 Operational Solar Power Satellites

The final stage in a roadmap for space solar power is the development, deployment and operation of a full-scale SPS to deliver substantial energy to commercial markets, including baseload power markets. The details of how such an operational system would be achieved will vary greatly depending on what SPS Type is to be developed. However, the strategic backbone of the SSP roadmap presented here is a clear progression from studies to designs to development of an operational SPS according to the standard aerospace systems engineering process: from Pre-Phase A, to Phase A to Phase B, and then to Phase C/D for both the SPS platform, and for key SPS supporting systems and infrastructure.

8.8 Summary

A broad range of technical challenges must be addressed in order to establish the economic feasibility of SPS, and – if appropriate – to subsequently proceed with their development. It is possible that a single government or major company might surmount these challenges. However, timely success seems more likely to result from cooperation in accomplishing R&D objectives among governments, among industry players and among a broad range of government, corporate and academic organizations.

A variety of tests and demonstrations of one key SPS technology – wireless power transmission – have been performed since the 1960s. Many of these tests have involved component technologies that are not directly relevant to validating the economic viability of SSP. Moreover, selected early demonstrations have been performed by various organizations almost as a means of “getting their feet wet” – i.e., in learning the basics of WPT and/or SPS. Unfortunately, the next steps in moving higher in the TRL

scale require considerably greater funding (i.e., from the lower left to the upper right in the roadmap); these key steps have not yet been taken.

Timely communication of plans and results from SPS technology R&D activities is crucial to coordinated progress. The ongoing Space Power Symposium, organized annually under the auspices of the International Astronautical Federation (IAF), has served a highly useful role in this regard. Similarly, periodic conferences dedicated to SPS and WPT have been held over the past 20+ years in various countries (e.g., WPT 1995, SPS 2004, etc.); these have been highly useful in promoting international dialog and coordination of SSP efforts.

It is the consensus of the IAA that SSP systems are technically feasible. However, the successful development of the SPS concept – and the determination of markets might be served economically – cannot be accomplished without investments in systems-level, end-to-end studies, ground and flight demonstrations at higher TRL levels, and eventually the launch of major sub-scale SPS pilot plant demonstrations.

The preceding chapter has presented a preliminary international roadmap, framed in strategic terms, for the potential exploration of the SPS concept. This roadmap is not highly specific – it does not prescribe a specific budget, nor does it involve a specific schedule. However, it provides a possible framework for future SPS related activities by indicating a logical sequence for various steps, and the conceptual relationships among those steps. Moreover, it is the consensus of the IAA that significant progress could be made during the next 10-15 years – leading to a large, but sub-scale SPS pilot plant.

CHAPTER 9

CONCLUSION: FINDINGS AND RECOMMENDATIONS

Despite the various studies of space solar power conducted by different countries and organizations during the past four decades, there had not yet been an integrated international assessment of the concept. The IAA study “Space Solar Power: an International Assessment of Opportunities, Issues and Potential Pathways Forward,” has conducted such an assessment.

The IAA study for SSP/SPS has produced a formal report of the results of the effort; it incorporates a high-level roadmap for how the international community might best proceed in developing and – perhaps – deploying this important option for future global sustainable energy.

The target community for this document includes (a) the membership of the Academy; (b) the broader academic and industry aerospace community; (c) the non-aerospace environmental and energy industry community; and, (d) policy makers, including international space agency leadership and stakeholders within the several space-faring nations.

This Chapter presents the summary findings and recommendations of the IAA study, and concludes with some high-level observations.

9.1 Summary of Study Findings

Based on the results of the IAA assessment of the concept of solar energy from space, the Academy makes the following findings regarding the concept of future solar energy delivered from space for markets on Earth:

Finding 1: Fundamentally new energy technologies clearly appear to be needed during the coming decades under all examined scenarios – both to support continued (and sustainable) global economic growth, and for reasons of environmental/climate concerns. Solar energy from space appears to be a promising candidate that can contribute to address these challenges.

Finding 2: Solar Power Satellites appear to be technically feasible as soon as the coming 10-20 years using technologies existing now in the laboratory

(at low- to moderate- TRL) that could be developed / demonstrated (depending on the systems concept details).

- **Finding 2a:** There are several important technical challenges that must be resolved for each of the three SPS systems types examined by the IAA study.
- **Finding 2b:** The mature (high-TRL) technologies and systems required to deploy economically viable SPS immediately do not currently exist; however, no fundamental breakthroughs appear necessary and the degree of difficulty in projected R&D appears tractable.
- **Finding 2c:** Very low cost Earth to orbit transportation is a critically needed supporting infrastructure in which new technologies and systems must be developed to establish economic viability for commercial markets.

Finding 3: Economically viable Solar Power Satellites appear achievable during the next 1-3 decades, but more information is needed concerning both the details of potential system costs and the details of markets to be served.

- **Finding 3a.** SPS do appear economically viable under several different scenarios for future energy markets, including potential government actions to mediate environment/climate change issues.
- **Finding 3b.** The economic viability of particular Solar Power Satellite concepts will depend upon both the markets to be served, and the successful development of the technologies to be used (including required levels of performance (i.e., key figures of merit for SPS systems).
- **Finding 3c:** The potential economic viability of SPS has substantially improved during the past decade as a result of the emergence both of government incentives for green energy systems, and of “premium niche markets”.
- **Finding 3d.** Establishing the economic viability of SPS will likely require a step-wise approach, rather than being achieving all at once – in particular SPS platform economics, space transportation economics, in-space operations economics, integration into energy markets, etc., will likely require iterative improvements to build confidence and secure funding for further developments.

- **Finding 3e.** Given the economic uncertainties in developing and demonstrating SPS technologies and systems and the time required, it is unlikely that private sector funding will proceed alone; i.e., government involvement and funding support is likely needed.

Finding 4: An in-depth end-to-end systems analysis of SSP/SPS is necessary to understand more fully the interactions among various systems / technologies for different concepts and markets; however, no such study has been performed since the conclusion of NASA’s Fresh Look Study in 1997.

- **Finding 4a:** Scenario-based study approaches can be extremely useful in examining prospective markets for visionary future systems such as SPS, but must provide sufficient detail to enable one to distinguish from among various SPS systems options.
- **Finding 4b:** Special attention appears needed to refresh understanding of prospects for space applications of SSP systems and technologies, with attention to the enabling role that low-cost electrical power in roughly the megawatt range could play for ambitious future space missions and markets.

Finding 5: Low-cost Earth-to-orbit transportation is an enabling capability to the economic viability of space solar power for commercial baseload power markets.

- **Finding 5a:** Extremely low cost ETO transportation systems appear to be technically feasible during the coming 20-30 years using technologies existing in the laboratory now (at low- to moderate- TRL) that could be developed / demonstrated (depending on the systems concept details). However, the technologies required for this future space capability are not sufficiently mature for system development to begin at present.
- **Finding 5b:** Acceptable ETO systems for future SPS must be “environmentally benign” – i.e., space transportation infrastructures to launch the satellites cannot result in harmful pollution of the atmosphere.

Finding 6: Systems studies are not enough. Technology Flight Experiments (TFEs) to test critical technology elements and Technology Flight Demonstrations (TFD) that validate SPS systems concepts to a high level of maturity (“TRL 7⁵¹) appear to be essential in order to build confidence

⁵¹ “TRL” refers to the “technology readiness level” scale; see Appendix C.

among engineers, policy makers, and the public and allow space solar power technology maturation and SPS deployment to proceed.

- **Finding 6a:** The International Space Station (ISS) appears to represent a highly attractive potential platform at which various SSP and related technology flight experiments (TFEs) could be performed.
- **Finding 6b:** Free flying spacecraft appear to be an attractive option for selected SSP TFEs and systems level demonstrations.

Finding 7: Architectural approaches that most efficiently and seamlessly integrate energy delivered from SPS into existing terrestrial energy networks are likely to be the most successful. (The same is true for any transformational new energy technology.)

Finding 8: The SPS concept is sufficiently transformational and entails enough technical uncertainties such that major systems level in-space demonstrations will be necessary to establish technical feasibility, engineering characteristics and economical viability before any organization is likely to proceed with full-scale development.

- **Finding 8a.** The likely investment in technology maturation, hardware development and system deployment for a very low-cost, highly reusable space transportation (HRST) system will require some 10s of billions of dollars (\$, US). If the SPS concept is the sole – or even a significant – market justification for such a development, then it is likely that a large-scale, pilot plant type demonstration of the SPS to be launched will be required prior to a government and/or commercial commitment to fielding HRST systems or supporting infrastructure.
- **Finding 8b.** In-space systems and infrastructures that will support SPS deployment, assembly, servicing, etc. will be intimately related to the detailed designs and characteristics of the SPS platform, and to the design of supporting ETO systems (see Finding above). Such in-space systems will likely need to be developed and demonstrated in tandem with, if not prior to, the implementation of an SPS pilot plant demonstration.

Finding 9: A variety of key policy-related and regulatory issues must be resolved before systems-level demonstrations – particularly space based tests – of SPS and WPT can be implemented.

- **Finding 9a.** Spectrum management is an issue of particular importance that must be addressed early due to the time-consuming

international processes that are in place vis-à-vis use of the electromagnetic spectrum and orbital slot allocations.

- **Finding 9b.** A number of operational issues that are related to international cooperation and coordination, including WPT transmission safety requirements, orbital debris generation and management, etc., must also be addressed early.
- **Finding 9c.** Policy related and regulatory issues will require considerable time to resolve, making the need to begin discussions in a timely way very pressing, particularly for SPS and related technology in-space tests and demonstrations.

9.2 Study Recommendations

Based on the results of the IAA assessment of the concept of solar energy from space, the Academy offers the following recommendations for the consideration of the international community.

Recommendation 1: Both government-supported and commercially funded SSP systems analysis studies should be undertaken that have sufficient end-to-end breadth and detail to fully resolve the R&D goals and objectives that must be achieved to establish the viability of SSP.

- **Recommendation 1a:** Where possible, SSP and related systems analysis studies recommended should be coordinated among various countries and between industry and government agencies.
- **Recommendation 1b:** It is recommended that focused and rigorous market studies should be included in future integrated/end-to-end SPS systems studies; a scenario-based approach should be considered as a key element of such studies. In addition, such studies should include more detailed analysis of “premium niche markets” in various countries and/or for specific customers.
- **Recommendation 1c:** Future systems analysis / market studies should examine explicitly the potential integration of SPS / WPT concepts into existing (or projected) terrestrial energy networks. These studies should involve additional non-aerospace sector experts (for example, from the energy and utility sectors.)
- **Recommendation 1d:** Future systems studies should examine in greater detail the comparison of SPS with other energy technologies for

various market opportunities, including both nearer-term technologies (such as ground solar) and farther term technologies (such as fusion).

- **Recommendation 1e**: Future systems studies should address a range of detailed issues, including policy and economic considerations, GEO orbital slot availability, operational issues (e.g., in-space assembly / infrastructure, SPS reliability and failure considerations), and orbital debris. These studies should examine Earth-to-orbit and in-space transportation issues carefully.
- **Recommendation 1f**: Future systems studies should place appropriate emphasis on better life cycle cost (LCC) estimates of SPS, including examining the impact of new models of large volume production of space systems.

Recommendation 2: Future economic analyses should examine the potential role of non-space related government and international funding agencies in contributing to the development of SPS.

Recommendation 3: Government and commercial organizations should consider undertaking SSP and related technology R&D, including platform systems and supporting infrastructures (e.g., ETO, in-space transportation, in-space operations).

- **Recommendation 3a**: The International Space Station (ISS) should be considered as a potential platform on and from which a number of useful SSP and related technology flight experiments and tests could be performed.
- **Recommendation 3b**: Specific space solar power technology R&D activities – such as ground demonstrations and technology flight experiments – should be planned so as to best advance the overall state-of-the-art for SSP, and the results communicated as broadly as possible (consistent with restrictions due to intellectual property or government regulations).
- **Recommendation 3c**: It is recommended that as studies and technology R&D go forward that are directed toward SPS, WPT and related applications, there should be supporting research concerning WPT health and safety issues.
- **Recommendation 3d**: SSP technology development efforts should explicitly seek prospective nearer-term applications in support of international space goals and programs, such as space exploration.

- **Recommendation 3e:** Where possible, governments and commercial sector players should consider the formation of public-private partnerships to implement SSP technology development efforts; government agencies in particular should take steps to enable to encourage the formation of such partnerships.

Recommendation 4: The necessary policy and regulatory steps to enable SPS/WPT and related R&D to be conducted – leading to systems-level demonstrations – should be undertaken in the near term by government, commercial and other interested organizations.

- **Recommendation 4a:** It is recommended that particular attention should be paid to the allocation of spectrum for WPT technology development efforts and later system applications.
- **Recommendation 4b:** It is recommended that the formation of Public-Private Partnerships to pursue SSP technology maturation and system developments should be considered and encouraged where appropriate.

Recommendation 5: International organizations, such as the International Academy of Astronautics, should play a constructive role in fostering and guiding future SSP/SPS studies, technology developments and policy deliberations.

9.3 Concluding Remarks

The International Academy of Astronautics conducted during 2008-2010 the first broadly based international assessment of the concept of the solar power satellite: collecting solar energy in space and delivering it to markets on Earth via wireless power transmission. The Academy study found that the SPS concept has significant potential to meeting global requirements for largely carbon-neutral energy during the coming century. The study found the SPS concept to be technically viable, and that it may well be possible to achieve economic viability. However, it is also the view of the IAA that much more information is needed. In particular, systems analysis and market studies are needed that address the end-to-end technical issues of space solar power (SSP) in the context of 21st Century markets. Also, technology research and development, leading to flight experiments and demonstrations in space is needed that can resolve the key technical and programmatic barriers to economic viability.

The needed studies of space solar power and supporting research and development should be undertaken by a variety of organizations and countries working in concert, including various space agencies, companies, universities and non-governmental organizations. And, as progress is made, there will be numerous important opportunities to apply emerging SSP technologies and systems in terrestrial and space based applications; these interim applications should be pursued with vigor – and could provide an ongoing motivation for, and benefit from the implemented studies and R&D.

APPENDICES

The following are the several appendices of this report, including the following:

- *Appendix A* is a glossary of acronyms
- *Appendix B* provides lists of the formal participants in the IAA study, as well as the various participants in the September 2009 IAA workshop (“SPS 2009”) in Toronto, Canada.
- *Appendix C* provides a copy of the originally submitted proposal for the study.
- *Appendix D* provides additional details regarding the three SPS system concepts examined by the study.
- *Appendix E* presents details of the technology readiness and risk assessment, including definitions of the TRLs (technology readiness levels), R&D³ scale (research and development degree of difficulty), and TNVs (technology need values), as well as detailed TRRA results.
- *Appendix F* presents the systems analysis methodology used by the study.
- *Appendix G* provides a selection of past Wireless Power Transmission tests (ground and flight).
- *Appendix H* provides a conceptual comparison of typical power demand and the intermittent character of wind and ground-based solar power sources.
- *Appendix I* provides the References for the final report.
- In addition, in separate documentation, the key references for the IAA study final report including the various papers / presentations development for, and delivered at the Toronto, Canada SPS 2009 workshop.

APPENDIX A

GLOSSARY OF ACRONYMS

A/B	Aerobrake
ACS	Attitude Control System
AFRL	(US) Air Force Research Laboratory
AIAA	American Institute of Aeronautics and Astronautics
AIST	Affordable In-Space Transportation
ASEB	(U.S. / NAS) Aeronautics and Space Engineering Board
ATLAS	Advanced Technology Life-cycle Analysis System
BIPV	Building Integrated PV
bn	Billion
C	Celsius
CBC	Canadian Broadcasting Company
CD	Concept Dependent
CDS	Command and Data System
CFM	Cryogenic Fluid Management
CNES	Centre National d'Etudes Spatiales (the French Space Agency)
CNT	Carbon Nanotubes
CONOPS	Concepts of Operations
COPUOS	(UN) Committee on the Peaceful Uses of Outer Space
CPD	Cryogenic Propellant Depot
CPV	Concentrator PV
CSA	Canadian Space Agency
CSI	Controls-Structures Interactions
CSP	Concentrated Solar Power
CSS	Canadian Space Society
CSTS	Commercial Space Transportation Study
Delta-v	Delta-velocity (also known as “ Δv ” or change in velocity)
DIPS	Dynamic Isotope Power System(s)
DOD	(U.S.) Department of Defense
DOE	(US) Department of Energy

DSM	Degree of Systems Modularity
\$	Dollars (US, unless otherwise specified)
EADS	European Aeronautic Defense and Space (Company)
EELV	Evolved Expendable Launch Vehicle
ELV	Expendable Launch Vehicle
EM	Electromagnetic
E-M L1	Earth-Moon Libration Point L1
EPT	Energy Payback Time
ERDA	(US) Energy Research and Development Agency
ESA	European Space Agency
ESTEC	European Space Research and Technology Centre
ETO	Earth-to-Orbit (Transportation)
FET	Field Effect Transistor
FOM	Figure of Merit
FTE	Full-Time Equivalent
g	(Earth) gravity
GEIS	Ground Energy and Interface System(s)
GEO	Geostationary Earth Orbit
GHG	Greenhouse Gas(es)
GLOW	Gross Lift-Off Weight
GN&C	Guidance, Navigation and Control
GSP	Ground Solar Power
GTO	GEO Transfer Orbit
GW	Gigawatts
HLLV	Heavy Lift Launch Vehicle
HMM	Human Mars Missions
HRST	Highly Reusable Space Transportation
HST	Hubble Space Telescope
HTS	High-Temperature Superconductor
H/W	Hardware
IAA	International Academy of Astronautics
IAC	International Astronautical Congress
IAF	International Astronautical Federation
ICAO	International Civil Aviation Organization
IEA	International Energy Agency

IECEC	International Energy Conversion and Engineering Conference
ISAAC	In-Space Assembly and Construction
ISAMS	In-Space Assembly, Maintenance and Servicing
ISAS	Institute of Space and Astronautical Science
ISC	Integrated Symmetrical Concentrator
ISM	Industrial, Scientific and Medical (RF bands)
Isp	Specific Impulse
ISPP	<i>In Situ</i> Propellant Production
ISS	International Space Station
ISRU	<i>In Situ</i> Resource Utilization
ISTS	International Symposium on Technology and Science
ITU	International Telecommunications Union
J	Joules
JAXA	Japan Aerospace Exploration Agency
JWST	James Webb Space Telescope
K	Kelvin
kW	kilowatts
LaRC	(NASA) Langley Research Center
LCC	Life Cycle Cost
LEO	Low Earth Orbit
LH2	Liquid Hydrogen
LLC	Limited Liability Company
LLO	Low Lunar Orbit
LMO	Low Mars Orbit
LOX	Liquid Oxygen
L-Point	Libration Point
LSP	Lunar Solar Power
m	Meters
MagLev	Magnetic Levitation
MCC	Mission Control Center
MEO	Middle Earth Orbit
METI	(Japan) Ministry of Economy Trade and Industry (formerly MITI)
METS	Microwave Energy Transmission in Space
MF	Mass Fraction

MIC	Magnetically Inflated Cable(s)
MINIX	Microwave Ionosphere Nonlinear Interaction eXperiment
MMW	Multi-megawatt
MOCC	Mission Operations Control Center
MRHE	Modular, Reusable High Energy (System)
MSFC	(NASA) Marshall Space Flight Center
mt	Metric Tons
MTBF	Mean Time Between Failures
MW	Megawatts
NAS	(U.S.) National Academy of Sciences
NASA	(NASA) National Aeronautics and Space Administration
NLT	Not Less Than
NRC	(U.S.) National Research Council
NRL	Naval Research Laboratory
NSF	National Science Foundation
NSS	National Space Society
NSSK	North-South Station Keeping
NSSO	National Security Space office
NTP	Nuclear Thermal Propulsion
O&M	Operations and Maintenance
OSC	Ontario Science Center
OTV	Orbital Transfer Vehicle
P/L	Payload
PMAD	Power Management and Distribution
PNM	Premium Niche Market
PV	Photovoltaic
R&D	Research and Development
R&D3	R&D Degree of Difficulty
RBCC	Rocket Based Combined Cycle
Rectenna	Rectifying Antenna
RES	Renewable Energy System(s)
RF	Radio Frequency
RHU	Radioisotope Heating Unit
RLV	Reusable Launch Vehicle
RTG	Radioisotope Thermoelectric Generator

s	Seconds
SAIC	Science Applications International Corporation
SAMS	Space Assembly Maintenance and Servicing
SbSP	Space-based Solar Power
SE L1	Sun-Earth L1 Libration Point (etc. for SE L2)
SEPS	Solar Electric Propulsion System
SERT	SSP Exploratory Research and Technology Program
SETI	Search for Extraterrestrial Intelligence
SHARP	Stationary High Altitude Relay Platform
SNR	Space Nuclear Reactor
SpaceCanada	Solar Power Alternative for Clean Energy - Canada
SPG	Solar Power Generation
SPS	Solar Power Satellite
SSP	Space Solar Power
SSPS	Space Solar Power Satellite
SSTO	Single-Stage-to-Orbit (Launcher)
S/W	Software
TBCC	Turbine Based Combined Cycle
TBD	To Be Determined
TFE	Technology Flight Experiment
TMS	Thermal Management System
TNV	Technology Need Value
TRA	Technology Readiness Assessment
TRL	Technology Readiness Level
TRRA	Technology Readiness and Risk Assessment
TSTO	Two-Stage-to-Orbit (Launcher)
T/W	Thrust-to-Weight (Ratio)
TWT	Traveling Wave Tube
USA	United States of America (also used as "US")
USAF	United States Air Force
USEF	(Institute for) Unmanned Space Experiments Free Flyer
UOOSA	United Nations Office for Outer Space Affairs
VTHL	Vertical Take-Off / Horizontal-Landing
VTVL	Vertical Take-Off / Vertical-Landing
WPT	Wireless Power Transmission

APPENDIX B

IAA STUDY PARTICIPANTS

B.1 Principal IAA Study Participants

Table B.1 identifies the principal participants of the IAA space solar power study.

Table B.1 Study Participants (27 March 2008 / Updated)

Name	Role	Organization / Notes
John C. Mankins	Chair	Artemis Innovation Management Solutions LLC
Prof. Nobuyuki Kaya	Co-Chair	Kobe University
Henry Brandhorst, Ph.D.	Member	Auburn University / Center for Space Power & Advanced Electronics
A.C. Charania	Member	Spaceworks Engineering, Inc. - Commercial
Raghavan Gopalaswami	Member	Government of India, Air Commodore (Retired)
Joe T. Howell	Member	NASA Marshall Space Flight Center
Koichi Ijichi	Member	Unmanned Space Experiments Free Flyer Institute (USEF)
Frank Little, Ph.D.	Member	Texas A&M University / Center for Space Power
Shoichiro Mihara	Member	Unmanned Space Experiments Free Flyer Institute (USEF)
Susumu Sasaki, Ph.D.	Member	Japan Aerospace Exploration Agency (JAXA @ ISAS)
Peter Swan	Member	IAA Commission VI
Leopold Summerer	Member	European Space Agency (ESA @ Advanced Concepts Team / ESTEC)
Janet Verrill	Member	Sunsat Energy Council / Space Power Association
Robert Wegeng	Member	Pacific Northwest National Laboratory (Battelle Memorial Institute)
Tetsuo Yasaka, Ph.D.	Member (Invited)	Kyushu University
Didier Vassaux	Member	CNES

B.2 International Symposium Participants

In addition to the formal members of the IAA study, a diverse collection of international subject matter experts (SMEs) participated in a September 8-10, 2009, International Symposium on Solar Energy from Space that was held at the Ontario Science Center (OSC) in Toronto, Canada. The IAA study organized the meeting in cooperation with SPACE Canada, and others. Table B.2 identifies the participants in workshop at the OSC.

Table B.2 SPS 2009 Workshop Participants

Name	Organization
John C. Mankins	IAA SES SG Co-Chair; Artemis Innovation Management Solutions LLC
Prof. Nobuyuki Kaya, Ph.D.	IAA SES SG Co-Chair; Kobe University
Wael Almazeedi	QGen, Inc. / FATE Ltd. Consortium
Terrence Baine	University of Oslo
W. Keith Belvin, Ph.D.	NASA Langley Research Center
Dallas Bienhoff	The Boeing Company
Henry Brandhorst, Ph.D.	Auburn University
Kieran A. Carroll	SpaceCanada
A.C. Charania	SpaceWorks Engineering, Inc. (SEI)
Patrick Collins	Azabu University
Jonathan Coopersmith, Ph.D.	Texas A&M University
Michael M. Davis, Ph.D.	Cornell University / SETI Institute / Hat Creek Radio Observatory
Patricia Day	McGill University
Richard Dickinson	Off-Earth WPT, Inc. (NASA Jet Propulsion Laboratory, retired)
George Dietrich	SpaceCanada
John Dorsey	NASA Langley Research Center
David Dunlop	The Moon Society
Paul Eckert	The Boeing Company

Name	Organization
Bryan Erb, Ph.D.	Canadian Space Agency (retired)
Don Flournoy, Ph.D.	Ohio University, School of Media Arts and Studies
Air Cmde R. Gopalswami (Paper Presented by Proxy)	Chairman of the Board & Managing Director, Bharat Dynamics Ltd. (retired)
Julius Grodski	(Canada) Department of National Defense
Monica Gupta	QGen, Inc.
Kozo Hashimoto, Ph.D.	Kyoto University (Research Institute for Sustainable Humansphere)
Johanne Heald	Canadian Space Agency
Kris Holland	Mafic Studios, Inc.
Mark Hopkins	National Space Society
Steve Horvath	Canadian Space Society (CSS)
Joseph T. Howell	NASA Marshall Space Flight Center (ret.)
Alex Ignatiev, Ph.D.	University of Houston
Alexander M. Jablonski, Ph.D.	Canadian Space Agency (CSA)
Paul Jaffe	U.S. Naval Research Laboratory (NRL)
Ram Jaku, Ph.D.	McGill University / Faculty of Law
Geoffrey Languedoc	Canadian Aeronautics and Space Institute
Eva-Jane Lark	BMO Nesbitt Burns
William Maness	PowerSat, Inc.
Bob McDonald	SpaceCanada and the Canadian Broadcasting Company (CBC)
Margaret McLaughlin	SpaceCanada
James McSpadden, Ph.D.	Raytheon Company
Brian Mengwasser	Dartmouth College
Shoichiro Mihara	Unmanned Space Experiments Free Flyer Institute
Ralph Nansen	The Boeing Company (Retired)
Jay Penn, Ph.D.	The Aerospace Corporation

Name	Organization
James R. Powell, Ph.D.	PlusUltra (Brookhaven National Laboratory, retired)
John Strickland	National Space Society
Susumu Sasaki, Ph.D.	Japan Aerospace Exploration Agency (JAXA) / Institute of Space and Astronautical Science (ISAS)
Kevin Shortt	Canadian Space Society (CSS)
Tarlochan Sidhu	University of Western Ontario
Rainee Simons, Ph.D.	NASA Glenn Research Center
Frank Steinsiek	EADS Astrium - Bremen
Christina Stephens	FATE Consortium
John Strickland	National Space Society
Leopold Summerer (via Videoconference)	European Space Agency (ESA @ Advanced Concepts Team / ESTEC)
Stephen Tenssel	Space Energy
Janet Verrill	Sunsat Energy Council
Michael Webber	GTC Law Group
Robert Wegeng	Pacific Northwest National Laboratory / Battelle Memorial Institute
Victor Wehrle	Canadian Space Agency (Retired)
Erinn van Wynsberghe	McMaster University student

APPENDIX C

IAA STUDY TERMS OF REFERENCE

The following is submitted proposal for the study. (Note: the membership of the study was revised during implementation; see Appendix B for the study roster.)

IAA, Paris, October 2000 Study Group Form (comments and form available on <http://www.iaa.net.org/news>)

-1-

Proposal for Forming an IAA Study Group

Title of Study:
Solar Energy from Space: the First International Assessment of Opportunities, Issues and Potential Pathways Forward

Proposer(s):
John C. Mankins
Prof. Nobuyuki Kaya

Primary IAA Commission Preference:
Commission 3
Secondary IAA Commission Interests:
Supporting Participants from IAA Commissions 5 and 6 have asked to participate in the study (see annotation below)

Members of Study Team (proposed)

Chairs: John C. Mankins
 Nobuyuki Kaya

Secretary: Jerry Grey

Other Members: Ivan Bekey
 Henry Brandhorst, Ph.D.
 Paul Eckert
 Peter Glaser (ex officio)
 Raghavan Gopaldaswami
 Joe T. Howell
 Greg Maryniak
 Neville I. Marzwell, Ph.D.
 Susumu Sasaki, Ph.D.
 Michael Smith
 Leopold Summerer
 Didier Vasseaux
 Robert Wegeng
 Prof. Dr. Kai-Uwe Schrogl (representing IAA Commission V)
 (Note: per P. Swan; should be regarded as "invited" at this time)
 Peter Swan (representing IAA Commission VI)
 Additional members, to be identified.

Short Description of Scope of Study**Introduction and Rationale**

Past advances in the global quality of life have been enabled by rapid growth in *per capita* energy use, including both electricity and various fuels. During coming decades, global demand for affordable and abundant energy will continue to grow rapidly. However, it is also becoming increasingly urgent to take concerted action on a number of critical environmental issues – particularly with respect to greenhouse gasses and global climate change. Technology will play a vital role in this unfolding situation, because vast, new and sustainable sources of energy will be needed if the burgeoning per capita demand is to be satisfied without exacerbating climate change further.

In fact, during the past several decades, space systems and technologies have played significant roles in meeting environmental challenges. For example, space has proven to be one of humanity's best vantage points from which to observe and better understand our Earth. In coming decades, action will be required in addition to understanding. One option for such action is the development of space-based solar power systems (a.k.a., "space solar power" or "solar power satellites"), first proposed in the late 1960s.

International interest in the topic of space solar power has dramatically increased during the past decade—driven by increasing recognition of the risks of global warming and dramatic increases in the costs of energy—and enabled by a wide range of impressive advances in key component and subsystem technologies. This interest has been expressed through a variety of R&D efforts, including studies and technology development in the U.S. (NASA & NSF, 1995-2003), ongoing R&D in Japan (JAXA, USEF), recent and ongoing studies in Europe (ESA), more recent studies in the U.S. (for the first time under the leadership of the DOD), as well as interest in other space-faring countries of importance, such as India and China. The recent visionary statements (at the 2007 IAC in Hyderabad) endorsing space solar power by the former President of India, Dr. Abdul Kalam, have been particularly remarkable.

However, despite increasing interest in space solar power and despite various R&D activities and studies by individual countries, fundamental questions remain regarding the economic viability of the concept in the foreseeable future.

Despite the numerous SSPS efforts of individual countries and programs, and regardless of the need for greater understanding of the prospects for, and limitations of this concept, there has never been an integrated international assessment of the technological, market and legal conditions under which SSPS might become economically viable. In particular, the International Academy of Astronautics has (to the knowledge of Commission 3) never undertaken a technical study involving the concept of space solar power, and certainly not during the past two decades. Moreover, although there is a long-standing "Power Committee" within the International Astronautical Federation (IAF), that organization is limited to organizing meetings—e.g., a symposium at the International Astronautical Congress (IAC)—and has no charter to undertake a study of this or any other topic in the field of space power.

As a result of these considerations, it is entirely appropriate and timely for the IAA (through Commission III) to undertake a focused review and assessment of the SSPS concept for the purposes of accomplishing several important goals, described below.

Overall Goals:

The overall goals of this study is to determine what role solar energy from space might play in meeting the rapidly growing need for abundant and sustainable energy during the coming decades, to assess the technological readiness and risks associated with the SSPS concept, and (if appropriate) to frame a notional international roadmap that might lead the realization of this visionary concept.

Because significant advances in space solar power systems could have a profound and positive impact on human and robotic space exploration capabilities as well as a range of space applications, the study will also identify such opportunities and evaluate the potential for synergies (if any) between these benefits for space missions and SSPS for terrestrial markets. Finally, there have long been discussions of the potential role that extraterrestrial resources might play in SSPS architectures; the study will also attempt to identify these opportunities and assess potential connections between international lunar exploration programs now being undertaken and SSPS.

Intermediate Goals:

The following are the intermediate goals of the study:

- Identification of relevant markets and applications for new energy sources—including both ultimate applications in terrestrial markets, as well as interim applications in space programs.
- Identification and evaluation of the technical options that may exist for solar energy from space to contribute to meeting global energy needs.
- Identification and evaluation of the technical options that may exist for space solar power to contribute to ambitious government and commercial space mission concepts and markets
- Identification and evaluation of options for the utilization of extraterrestrial resources, in particular lunar resources in future space solar power systems\
- Preliminary determination of appropriate SSPS architecture level figures-of-merit, and values of these that must be achieved in order for solar energy from space is to become economically viable for a range of terrestrial market opportunities and space applications.
- Preliminary identification of other issues and policy questions that would require resolution for SSPS to become a reality (e.g., spectrum allocation).
- Assessment of the technical feasibility, technological maturity and degree of difficulty in the above space solar power options.
- Formulation of a strategic approach to realizing the potential of energy from space—and one or more technical / programmatic roadmaps implementing this strategy.
- Development of a summary report, documenting the results of the study and articulating the prospects for Energy from Space to make a substantial contribution to satisfying future global needs.

These initial intermediate goals will be updated during the course of the study.

IAA, Paris, October 2000

Study Group Form (comments and form available on <http://www.iaa.net.org/news>)

-4-

Methodology:

The study shall be organized within a functional work breakdown structure, emphasizing relevant systems and technologies, but including other factors as appropriate (e.g., market assessments), and implemented through primarily through a web-based approach with periodic working meetings at IAA meetings and major conferences where appropriate (e.g., at the IAC IPC in spring 2008, the IAC in fall 2008, etc). In addition, one or more dedicated working meetings will be organized, and at least one major workshop/conference. In addition, sessions will be organized at future International Astronautical Congresses in full cooperation with the IAF Power Committee, with papers being invited that address key topics in support of the study objectives. The results of these efforts will be documented in a formal final report, plus supporting information.

Time Line:

Major milestones will include: (1) project start (September 2007); (2) working meeting (March 2008); (3) workshop and presented papers (October 2009); (4) working meeting (March 2009); (5) study conclusion and initial report delivery for peer review (Fall 2009); study completion and report publication (Spring 2010).

Final Product (Report, Publication, etc.):

The study will result in a formal final report for peer review and subsequent publication by the IAA, as well as appropriate interim reports and proceedings from working meetings and workshops, and working papers presented at IAC congresses.

Target Community:

The target community for this study includes (a) the membership of the Academy; (b) the broader academic and industry aerospace community; (c) the non-aerospace environmental and energy industry community; and, (d) policy makers, including international space agency leadership and stakeholders within the several space-faring nations.

Support Needed:

Working support (e.g., in organization of sessions) will be required. IAA support for eventual study publication will be sought consistent with Academy guidelines.

Potential Sponsors:

Sponsors may include industry, non-government organizations, and space agencies.

To be returned to IAA Secretariat Paris fax: 33 1 47 23 82 16 email: sgeneral@iaa.net.org

Date: 23 September 2007

Signature:



For IAA Use Only:

APPENDIX D**SOLAR POWER SATELLITE SYSTEMS CONCEPTS: DETAILED DESCRIPTIONS**

The following Appendix provides additional details regarding the SPS concepts that were examined by the IAA study, including Type I: the microwave WPT SPS concept based on an update of the 1979 Reference System; Type II: the modular electric laser WPT SPS; and, Type III: the hyper-modular microwave WPT SPS concept based on the sandwich structure approach.

D.1 Generic Solar Power Satellite Functional Architecture

In order to evaluate and compare the various SPS approaches (identified in Section 2.1), it was necessary to determine if there are common functional elements that characterize most or all of these. Fortunately, this was indeed the case. Figure D-1 presents a high-level / generic solar power satellite (SPS) functional architecture that was used to characterize the several types of promising SPS system concepts.

The major categories of operations / systems within this generic SPS functional architecture are:

- Primary SPS Platform Systems
- Secondary SPS Platform Systems
- Ground Systems
- Supporting Systems / Infrastructure

The paragraphs that follow Figure D-1 provide the organization of each of the major elements of the generic SPS functional architecture into each of these categories. (Note: most of the elements listed are common to all types of SPS that are of interest. However, a number of them are identified as “options”. In these cases, the functional system element is needed for one or more of the SPS types, but is not needed in all cases.)

Figure D-1 Generic SPS Functional Architecture

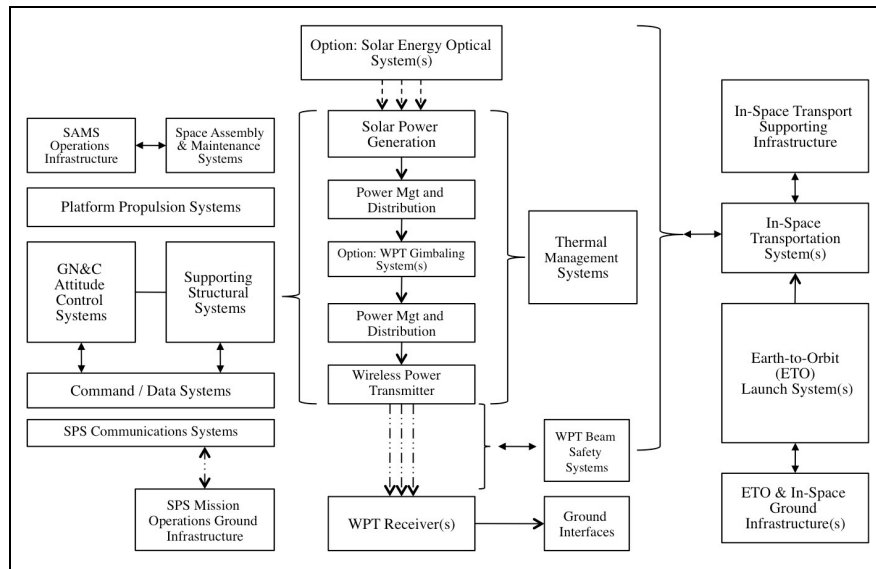

Primary SPS Platform Systems. The following are the major elements that comprise the primary systems of a generic SPS platform (including the end-to-end wireless power transmission system).

- Solar Power Generation (SPG)
 - SPG - Power Management and Distribution (PMAD)
 - SPG - Thermal Management Systems (TMS)
 - Option: SPG Solar Energy Optical Systems
- Platform PMAD System
 - Platform PMAD - Thermal Management Systems (TMS)
- Wireless Power Transmission System (WPT) – On-Board Transmitter
 - WPT - PMAD
 - WPT - TMS
 - Option: WPT Gimbal Systems
 - Option: WPT Gimbal PMAD
- WPT System – Ground Receiver
 - WPT Beam Safety Systems

Secondary SPS Platform Systems. The following are the most significant elements that constitute the secondary in-space systems of a generic SPS platform.

- Platform Structural Systems
- Guidance, Navigation and Control (GN&C) / Attitude Control Systems (ACS)
- Platform Propulsion Systems
- Command & Data Systems (CDS)
- SPS Communications Systems
 - On-Board Communications
 - Space-to-Space Communications
 - Space-to-Ground Communications
- Option: Space Assembly, Maintenance and Servicing Systems (SAMS) – Platform based

Ground Systems. The following are the major elements that comprise the primary ground systems that support a typical SPS platform.

- WPT Ground Energy Distribution Interfaces
 - Option: Power Grid Interface
 - Option: Power Grid Interface(s)
 - Option: Synthetic Fuel Production Interface(s)
- SPS Mission Operations Ground Infrastructure

Supporting Systems / Infrastructure. The following are the most important systems that comprise the common supporting infrastructure for a generic SPS platform.

- Earth-to-Orbit (ETO) Transportation
 - ETO Launch Vehicles
 - ETO Launch Infrastructure
 - ETO Mission Operations Ground Infrastructure
- In-Space Transportation (IST)
 - IST Vehicles
 - IST Ground Support Infrastructure
 - IST Mission Operations Ground Infrastructure
- Option: IST In-Space Supporting Infrastructure

- IST In-Space Refueling Platform(s)
- IST SAMS Systems(s)
- Option: In-Space Infrastructure
 - SPS In-Space Refueling Systems(s)
 - SPS SAMS Systems(s)

In the sections that follow, attention is next turned to a description of the three major types of SPS concepts in terms of the generic architecture described above.

D.2 SPS Reference and Updated Reference Concepts (SPS Type I)

D.2.1 Concept Overview

This approach is epitomized by the 1979 SPS Reference System concept and involves one or two large, sun-pointed solar collection systems and one or two Earth-pointed WPT systems. This is a large, 3-axis stabilized platform system architecture that involves the use of microwave radio frequency (RF) for WPT. Connecting the sun-pointing and the Earth-pointing systems is a large-scale power management and distribution system (either high-voltage or superconducting), including a “live” rotating coupler. This architecture option includes large-scale ground based rectenna systems as receivers for the microwave power, as well as appropriate operational safety assurance systems.

D.2.2 Architecture Details

The SPS 1979 Reference System and related updated approaches involve a number of unique architecture details that are distinct from the other SPS types that are the focus of the IAA study. Figure D-2 presents an end-to-end illustration of the 1979 Reference System concept. Figure D-3 provides an alternative perspective, emphasizing several of the key technologies, including the end-to-end wireless power transmission system.

1979 SPS Reference / Updated – Primary Platform Systems. The following are the major elements that comprise the primary systems of a generic SPS platform (including the end-to-end wireless power transmission system).

- *Solar Power Generation (SPG):* The SPG system for the 1979 SPS Reference System was Silicon PV cell array, attached to a large-scale, mechanically stiffened Aluminum frame structure. The array was

planned to operate at high-voltage for ease of integration with the SPG PMAD. The estimated energy conversion efficiency of the SPG was approximately 10% (i.e., 1/10th of the incoming sunlight would be converted into electrical current).⁵² The solar array and structure pointed continuous at the Sun during the satellite's 24-hour orbit.

- *SPG – Updated Technology*: In an updated version of the 1979 Reference, the SPT system could be modified in several ways. One change that is most typically discussed is the use of exceptionally thin film PV cells/arrays that allow for very low mass and very low cost at the cell level. At present, the energy conversion efficiency of such arrays is still around 10% or less. Other options for SPG for this Type of SPS, including concentrator-PV (CPV) that might involve the use of high-efficiency, multi-bandgap (MBG) PV cells that can currently achieve energy conversion efficiencies of more than 30%-35%.
- *SPG - Power Management and Distribution (PMAD)*: the PMAD system associated with the SPG for this concept would typically be a high voltage system (at approximately 10,000 volts or more), made of conventional metallic conductors.
- *SPG - Thermal Management Systems (TMS)*: The thermal management system for the SPG array can be expected to be largely passive in character.
- *Platform PMAD System*: An SPS of the 1979 Reference type requires the largest and potentially the most massive PMAD system, depending on the development of new PMAD technologies to reduce the mass of the system.
 - *Platform PMAD - Thermal Management Systems (TMS)*: Thermal management for the PMAD systems of an updated version of the 1979 Reference SPS may be expected to involve (1) the solar power generation system, (2) various spacecraft systems to which power is delivered, and (3) platform propulsion systems (expected to be electric propulsion). Specific TMS requirements will depend greatly on the power to be delivered, the voltages involved, transformers required, and the available fields of view for radiators.

⁵² Several alternative SPG options were also examined as part of the SPS studies of the 1970s, including simple concentrator options (using a trough concentrator) and Solar Dynamic options that would use a high concentration ratio reflector to provide high levels of solar flux to a heat engine (such as a Brayton Cycle engine).

Figure D-2 Overview of the 1979 Reference System SPS Architecture

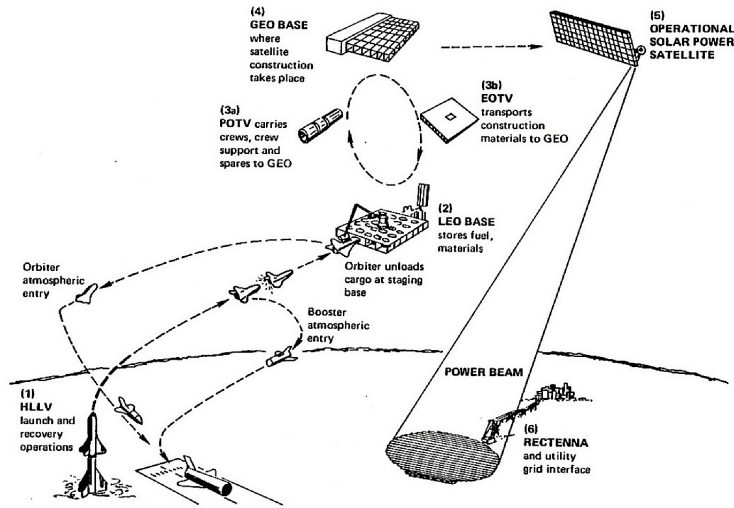

Credit: NASA / DOE Artwork c. 1979-1980

Figure D-3 1979 Reference System SPS Architecture – Key Technologies

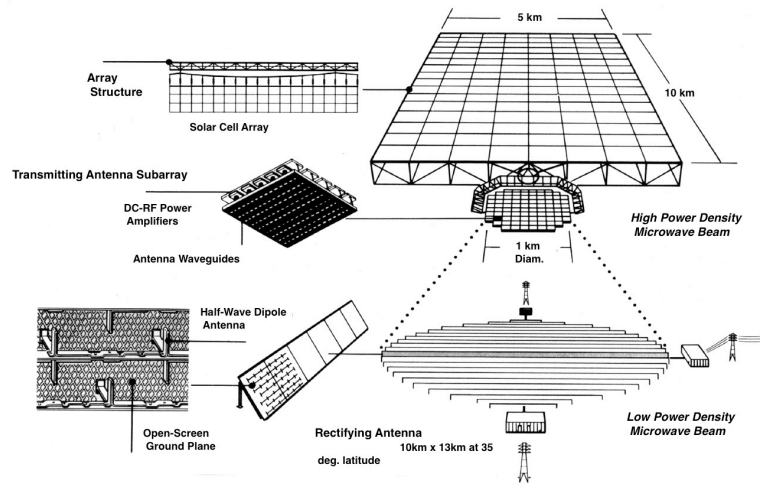

Credit: NASA / DOE Artwork c. 1979-1980

- *Wireless Power Transmission System (WPT) – On-Board Transmitter:* The baseline on-board WPT transmitter for the 1979 Reference System

concept was a high-efficiency electron tube approach, involving either Klystrons or Magnetrons, and a large-scale, rigid waveguide structure approximately 1,000 meters in diameter.

- *WPT - PMAD*: The wireless power transmission system PMAD subsystem for this SPS approach is highly tiered in character. It would involve power transmission across distances of up to 1 kilometer in multiple stages, and distribution across the power transmitter at distances of 10s of meters to 100s of meters. The overall PMAD system would typically operate at multiple voltages, with transformers (consistent with distribution), substations, and long-distance transmission from the SPG to the WPT subsystems.
- *WPT – TMS*: The WPT TMS for the 1979 concept involved local cooling from the backplane of the transmitter. The maximum RF power transmitted from the array at its center was greater than 10 kW-20 kW per square meter, with efficiencies of approximately 80% – resulting in a requirement for heat rejection of about 2 kW-thermal to 4 kW-thermal per square meter.
- *WPT Gimbal Systems*: The 1979 SPS Reference System involved a large scale Gimbal System for coarse pointing with an enormous frame mechanical pointing system some 200 meters in diameter and a yolk that held the transmitter array with a span of more than 1,000 meters. This system was used to provide nadir pointing of the WPT system at Earth while the solar array was continuously pointed at the Sun. (Fine pointing, on the order of plus/minus 10 kilometers, was to be provided by a retrodirective control system.)
- *Option: WPT Gimbal PMAD*: The system required a very high voltage PMAD system that continuously transferred up to 7,000 MW of power at high voltage (e.g., 10,000 volts or more).
- *WPT System – Ground Receiver*: The WPT ground receiver for the 1979 concept was a rectifying antenna (a “rectenna”), consisting of a very large number of distinct antenna elements, selected filters to reduce harmonics, high-efficiency diodes and a wiring harness to deliver the resulting DC current from the rectenna. For the baseline case, operating at a frequency of 2.45 GHz, the ground-based rectenna was in the shape of an ellipse with an East-West diameter of approximately 10 km, and a North-South diameter that would depend upon the Latitude at which the rectenna was located. Depending on the details

of the local context, this receiver might be placed within 100 km or less of the principal market(s) to be served.

- *WPT Beam Safety Systems:* An assured fail-safe, multi-tiered beam safety architecture and system is essential to the future deployment of SPS. The three tiers that are typically discussed include (1) physical isolation of the beam receiver so that under normal operations the beam intensity outside the boundaries of the receiving facility are below local beam intensity jurisdictional restrictions (e.g., in watts/m²); (2) active feedback from the ground to the platform in space to authorize transmission (preferable with strong encryption); and, (3) a real-time beam cut-off system to stop the transmission as may be necessary in very short times.

1979 SPS Reference / Updated – Secondary Platform Systems. The following are the most significant elements that constitute the secondary in-space systems of a generic SPS platform.

- *Platform Structural Systems:* The Platform Structural System for the SPS 1979 Reference System was assumed to be manufactured from Aluminum frame structural elements, fabricated from feedstock at a facility in GEO or elsewhere in high Earth orbit. These options would likely be adjusted via various technology updates, such as advanced composite structures.
- *Guidance, Navigation and Control (GN&C) / Attitude Control Systems (ACS):* The SPS Reference System platform type is a 3-axis stabilized system, not gravity gradient stabilized. The required GN&C and ACS systems may be expected to be substantial in any update to compensate for expected gravitational torques (e.g., from Moon, various solar system bodies, etc.). The ACS system would be required to work in complete tandem with platform propulsion system elements.
- *Platform Propulsion Systems:* The critical requirement that all GEO-based SPS platform propulsion systems must satisfy is for north-south station-keeping (NSSK) to compensate for various torques on the orbital position of the platform due to forces such as the gravitational pull of the Sun, the Moon and the major planets. For a satellite in GEO, this requirement is for an annual change in velocity of approximately 50 meters per second. The propellant mass necessary to accommodate this adjustment will depend upon the type of propulsion system used (e.g., chemical versus electrical, etc.). The very

large mass on either side of the gimbaling system will entail potential torques across the gimbal that will necessitate special attention in platform propulsion system design studies.

- *Command & Data Systems (CDS)*: CDS systems for an updated version of the traditional microwave SPS system could involve either a standard spacecraft data system architecture (i.e., a single, monolithic command and data system approach), or a more modular and networked approach.
- *SPS Communications Systems*: There are three classes of SPS communications system that are anticipated, these include: (a) on-board communications; (b) space-to-space communications; and, (c) space-to-ground communications; details include the following.
 - *On-Board Communications*: The baseline implementation of the 1979 SPS Reference System would have involved a primarily “stick-built” structure – i.e., one with only modest onboard intelligence, and therefore relatively limited on-board communications. Systems updates using advanced technology could entail a greater degree of on-board systems intelligence and much greater on-board communications traffic.
 - *Space-to-Space Communications*: The infrastructure-rich architecture of the 1979 SPS Reference System required extensive space-to-space communications.
 - *Space-to-Ground Communications*: The 1979 Reference required extensive space-to-ground communications from the various large platform complexes in LEO and GEO, as well as from the SPS platforms, and the various in-space transportation systems.
- *Platform-Based Space Assembly, Maintenance and Servicing Systems (SAMS) – Systems*: In the 1979 Reference SPS, there were only minimal platform-based SAMS systems – most if not all such functionality residing at substantial in-space facilities dedicated to that purpose. In an updated version of the “Microwave Classic” option, a greater degree of SPS-based SAMS functionality would be likely; however due to the large-scale of key system elements (e.g., the gimbaling system), this might be limited to on-board inspection systems, and highly-specific servicing functions (e.g., repair of wiring and harnesses, sealing leaks, etc.).

1979 SPS Reference / Updated – Ground Systems. The following are the major elements that comprise the primary ground systems that support a typical SPS platform.

- WPT Ground Energy Distribution Interfaces
 - *Power Grid Interface Option*: Power Grid Interface: The WPT receiving rectenna entailed a very large-scale power grid interface that could deliver up to 5,000 MW of power received into the local power grid. Other than the scale of power delivered, the power grid interface should be readily implemented with “smart grid” technology developments currently in progress.⁵³
 - *Synthetic Fuel Production Interface(s)*: A new concept that has emerged during the past several years is that of using energy delivered from an SPS to drive the production of synthetic fuels; there are several options for such an interface that apply equally to microwave and laser WPT cases, including direct thermal-chemical processing, electric power generation and utilization in electro-chemical processing and heating, and hybrid approaches.⁵⁴
- *SPS Mission Operations Ground Infrastructure*: SPS platforms will likely require appropriate mission operations control center infrastructure on Earth; the complexity and staffing for which will be critical to the life cycle cost (LCC) of the system. Details, particularly involving autonomous software systems and the space-based system elements will require close attention in design and development.

Supporting Systems / Infrastructure. The following are the most important systems that comprise the common supporting infrastructure for the 1979 Reference SPS System platform.

- *Earth-to-Orbit (ETO) Transportation*: The 1979 SPS Reference System depended upon a range of specially designed ETO transportation systems and supporting infrastructure, including ETO launch vehicles, launch support infrastructure, and ETO related mission operations infrastructure. The basic technology options of the time involved

⁵³ Generally speaking, ongoing advances in “smart grid” technology should make it much easier for local power utilities to accept power from SPS (just as they are increasingly accommodating the intermittent power from various renewable sources). This applies to all concepts.

⁵⁴ This concept – the production of fuel using energy delivered from an SPS – is generically applicable and applies to all three types of solar power satellite considered by the IAA study group.

technologies and systems of the Space Shuttle type; however, the details of the technology could be readily upgraded on a case-by-case basis.

- *ETO Launch Vehicles:* The baseline ETO launch vehicle assumed for the concept was a fully reusable two-stage-to-orbit (TSTO) vehicle. (See Figure 2-2, and Figure 3-2.)
- *ETO Launch Infrastructure:* The ETO launch vehicle required a highly specialized large-scale launch infrastructure including an oversized launch pad, fueling systems and supporting transport.
- *ETO Mission Operations Ground Infrastructure:* A range of ETO related ground infrastructure was required for the baseline concept, analogous to the mission control center (MCC) and communications networks used by the Space Shuttle program.
- *In-Space Transportation (IST):* A large-scale in-space transportation (IST) system is a central element of the 1979 SPS Reference System architecture, key sub-elements include the IST vehicles, IST ground support infrastructure, and various supporting infrastructures.
 - *IST Vehicles:* The baseline in-space transportation system was an electric propulsion system, potentially one that could receive WPT power from one or more SPS platforms. Either this approach, or solar electric propulsion systems (SEPS) represent a good reusable IST solution for the challenge of large-scale SPS deployment and maintenance. Due to the large-size of the SPS payloads to be transported and the low efficiency of solar power generation technologies of the 1970s, the vehicles in the reference architecture were also very large and were assembled in space. This approach may or may not be required in an updated version of the architecture, however, due to the significant advances in solar power technologies (e.g., conversion efficiency) that could enable a single launch IST vehicle.
 - *IST Ground Support Infrastructure:* IST ground support for this SPS architecture option could be made largely autonomous using technologies now available in terrestrial applications. For specific operations, these typically autonomous systems will also require tele-supervision as appropriate; hence, ground support infrastructure must include communications elements to provide

- high-bandwidth communications from mission operations to one or more vehicles simultaneously.
- *IST Mission Operations Ground Infrastructure:* As noted above, the IST system elements will of necessity require high levels of systems autonomy, combined with occasional periods of tele-supervised operation of specific vehicles.
 - *IST In-Space Supporting Infrastructure:* The reference approach from the 1970s for this SPS architecture appears to have required a large a varied number of IST in-space support infrastructures. Although the emphasis in most summaries is on the infrastructure requirements of the SPS platform itself (see below), nevertheless there are several clear requirements to support the IST system. In an updated version of this architecture, this requirement would almost certainly continue to be true.
 - *IST In-Space Refueling Platform(s):* A variety of in-space refueling stations were required, positioned in LEO and potentially in other orbits (particular GEO).
 - *IST SAMS Systems(s):* Because of the very large size of an individual SPS hardware module to be transported, the IST system was of necessity also quite large, and could be expected to entail dedicated space assembly, maintenance and servicing (SAMS) systems.
 - *In-Space Infrastructure:* Supporting in-space infrastructure is one of the defining characteristics of the 1979 Reference type of SPS concept. The principal element of this infrastructure – driven by the large-scale major systems of the SPS – would have been exceptionally large, LEO- and GEO- based factories where the individual components of the SPS would be fabricated and/or assembled into operational platforms.
 - *SPS In-Space Refueling Systems(s):* Substantial requirements for in-space refueling of the SPS platform propulsion systems would be required for this concept (particularly due to the need to support fully 3-axis stabilized ACS strategies).
 - *SPS SAMS Systems(s):* Various concepts could be involved in providing space assembly, maintenance and servicing on an ongoing basis to the “classic” type of SPS concept.

D.2.3 Characteristics of Key Supporting Systems

The family of SPS concepts of the 1979 Reference System type requires substantially greater supporting in-space infrastructure than other more-recently development concepts. As described above, these system-of-systems elements included various in-space platforms, and in-space transportation systems. One of the major initial investments that drove the projected cost of the 1979 SPS Reference System was the investment required to develop and deploy a very large-scale, reusable launch vehicle system. This heavy lift launch vehicle (HLLV) relied on a two-stage-to-orbit (TSTO) approach and was planned to launch approximately 250 MT of payload into a low Earth orbit (LEO). The gross liftoff weight (GLOW) of these systems was estimated to be as high as 11,000 MT. The facilities required to support these enormous HLLVs were extremely large as well and entailed extensive operations and maintenance (O&M).

D.2.4 Concept of Operations

The concept of operations (CONOPS) for the 1979 Reference System required a diverse range of systems in addition to those on the SPS platform itself. Generally speaking, the platform concepts involve large, integrated systems elements that will require either ground-based or platform-based monolithic command and control architectures.

D.2.5 Assessment Results

The 1979 SPS Reference System is the most traditional of the architectures examined in the IAA study. It employs – albeit at an extremely huge scale – a traditional three-axis stabilized platform architecture of the type that has been used in spacecraft since the 1960s. An updated version of this microwave WPT concept would take advantage of various advances in technology, including improvements in robotics, materials, electronics, and others. There appear, however to still be some very significant systems-technology challenges involved in the 1979 SPS Reference Concept approach – even including numerous advances in various component technologies.

The most significant challenges involve three issues. The first issue is the need for an extremely large, high-voltage power management and distribution system on the platform (including across the gimbaling system). Another issue is the requirement for substantial up-front

infrastructure both in –space and for ETO transport. Finally, there is the market support issue that the mechanically pointed transmitter array is far less capable of meeting “energy on demand” opportunities that other SPS concept types.

D.3 SPS Electric Laser Concepts (SPS Type II)

D.3.1 Overview

Laser Solar Power Satellite concepts can be of either of two basic types: (1) electric-laser based or (2) solar-pumped laser. At present, the former – electric lasers – appear to be the most feasible in the foreseeable future. Within the area of laser SPS, there are several alternative systems approaches, involving either integrated platforms comprising multiple individual laser systems or constellations of free-flying laser platforms. The following sections provide additional architectural details.

D.3.2 Architecture Details

The SPS Laser-type concepts and related updated approaches involve a number of architecture details that are similar to those of the Sandwich-type SPS concept, and distinct from those of the 1979 Reference-type SPS concepts, and related approaches. Figure D-4 presents an illustration of the end-to-end architecture for an integrated modular SPS electric laser system concept. Figure D-5 presents another view, emphasizing selected system elements.¹¹

Modular Electric Laser SPS – Primary Platform Systems. The following are the major elements that comprise the primary systems of a generic SPS platform (including the end-to-end wireless power transmission system).

- *Solar Power Generation (SPG):* The SPG system for a modular electric laser SPS would be amenable to a range of technology choices, ranging from thin-film PV (the use of exceptionally thin film PV cells/arrays that are capable of extreme low mass and very low cost) to concentrator options. At present, the energy conversion efficiency of such arrays is still around 10% or less. Other options for SPG for this Type of SPS, including concentrator-PV (CPV) that might involve the use of high-efficiency, multi-bandgap (MBG) PV cells that can currently achieve energy conversion efficiencies of more than 30%-

35%. The solar array and structure would be pointed continuously at the Sun during the satellite's 24-hour orbit.

- *SPG - Power Management and Distribution (PMAD)*: The PV array for this SPS concept would not require an exceptionally high-voltage PMAD system.
- *SPG - Thermal Management Systems (TMS)*: The thermal management system for the SPG array would depend on the specifics of the technology chosen, but could be largely passive in character.
- *Platform PMAD System*: In the case of an integrated modular electric laser SPS, the platform PMAD architecture would comprise a series of numerous individual PMAD systems, associated with each of the laser modules.
 - *Platform PMAD - Thermal Management Systems (TMS)*: Due to the highly concentrated character of the electric laser diode system concept, and need for these devices to remain at low temperatures, the platform thermal management system would be required to dissipate significant waste heat from relatively small areas – most likely using an active cooling system, and radiators operating at relatively high temperatures.
- *Wireless Power Transmission System (WPT) – On-Board Transmitter*: An assumption in the IAA study is that the laser power transmission system would be an electric-laser (as opposed to chemical laser or solar-pumped laser approaches). An important element of the WPT system for this SPS system type would be a high-precision optical beam expander capable of being pointed actively to the receiver on Earth.
 - *WPT - PMAD*: The wireless power transmission system PMAD subsystem for the electric laser SPS approach is intermediate-distance in character with significant power transmission across distances of up to 10s of meters, and would typically operate at multiple voltages, with transformers, consistent with distribution, substations, and intermediate-distance transmission from the SPG to the WPT subsystems.
 - *WPT – TMS*: The WPT TMS for the laser concept involved local cooling of the power conditioning and laser array the backplane of the array. The maximum optical power transmitted from each laser depends greatly on the beam intensity. However, the likely

power range per transmitter would likely be in the range from 10 kW to 100 kW per beam expander. The laser would likely operate with efficiencies of approximately 25% – resulting in a requirement for heat rejection of about 8 kW-thermal to 80 kW-thermal per laser transmitter.

Figure D-4 Illustration of an Integrated-Platform Laser SPS Concept – Overview

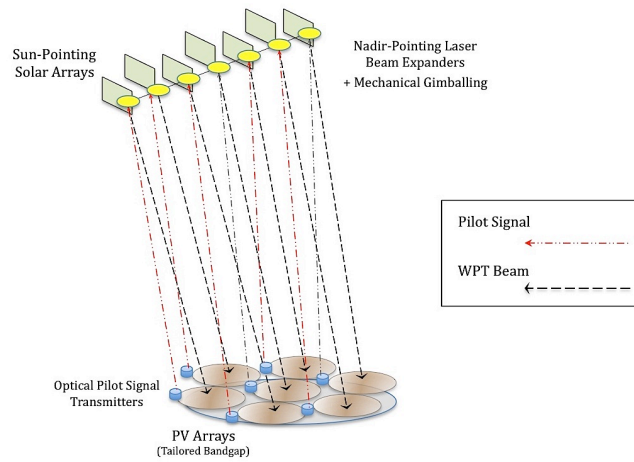

Credit: Artemis Innovation Management Solutions LLC

Figure D-5 Integrated-Platform Laser SPS Concept– Key Components

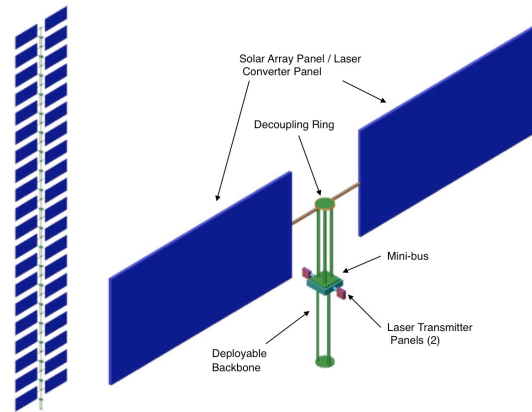

Credit: Aerospace Corporation; under contract to NASA

- *WPT Gimbal Systems*: The electric laser approach involved a numerous smaller scale gimbaling system with a moderate scale mechanical pointing system on the order of 1-2 meters in diameter. This system would provide nadir pointing of each individual WPT system toward the Earth while the solar array would be continuously pointed at the Sun.
- *WPT Gimbal PMAD*: The modular electric laser system required a high voltage PMAD system that continuously transferred up to power to the laser WPT transmitter at moderately high voltage (e.g., 1,000 volts or more); the specific power requirements for the gimbaling system depend on the total power to be delivered by the platform, the number individual laser transmitters, and the DC-to-laser conversion efficiencies of the devices used.
- *WPT System – Ground Receiver*: The WPT ground receiver for the laser SPS system concept is a tailored PV array, with higher efficiency than conventional solar power; expected efficiencies might be on the order of 60% or more. For a typical system, operating at a near-infrared frequency, the ground-based PV array would be in the shape of an ellipse with a longer North-South diameter than East-West diameter, where the North-South diameter that would depend upon the Latitude at which the PV array was located. The specific dimensions of the near-visible ground receiver must be determined consistent with maximum beam energy intensities vis-à-vis health and safety considerations. The same is true for receiver placement vis-à-vis markets to be served.
- *WPT Beam Safety Systems*: An assured fail-safe, multi-tiered beam safety architecture and system is essential to the future deployment of SPS. The three tiers that are typically discussed include (1) physical isolation of the beam receiver so that under normal operations the beam intensity outside the boundaries of the receiving facility are below local beam intensity jurisdictional restrictions (e.g., in watts/meter²); (2) active feedback from the ground to the platform in space to authorize transmission (preferable with strong encryption); and, (3) a real-time beam cut-off system to stop the transmission as may be necessary in very

short times. These tiers must be considered for SPS of the laser type as well as for RF type systems concepts.

Modular Electric Laser SPS – Secondary Platform Systems. The following are the most significant elements that constitute the secondary in-space systems of a generic SPS platform of the modular electric laser type.

- *Platform Structural Systems:* The structural systems for an individual laser module within the overall platform are likely to represent a relatively modest extension beyond current spacecraft systems (e.g., perhaps a factor of 10 increase in scale). The overall structure, including a large number of individual modules will require greater development, including both the interfaces, and the supporting structures.
- *Guidance, Navigation and Control (GN&C) / Attitude Control Systems (ACS):* The modular electric laser SPS platform type considered by the study is a 3-axis stabilized system concept.⁵⁵ The required GN&C and ACS systems may be expected to be substantial in any update to compensate for expected gravitational torques (e.g., from Moon, various solar system bodies, etc.). The ACS system would be required to work in complete tandem with platform propulsion system elements.
- *Platform Propulsion Systems:* The critical requirement that all GEO-based SPS platform propulsion systems must satisfy is for north-south station-keeping (NSSK) to compensate for various torques on the orbital position of the platform due to forces such as the gravitational pull of the Sun, the Moon and the major planets. For a satellite in GEO, this requirement is for an annual change in velocity of approximately 50 meters per second. The propellant mass necessary to accommodate this adjustment will depend upon the type of propulsion system used (e.g., chemical versus electrical, etc.). The laser tower approach may involve a linear configuration (extending above and below the orbit) that will require particular attention in detailed design studies.
- *Command & Data Systems (CDS):* CDS systems for a laser SPS concept could involve either a family of standard spacecraft data system architectures (i.e., multiple copies of a monolithic command and data system approach for each of the platform modules in the overall SPS,

⁵⁵ Alternative modular laser SPS may also be gravity gradient stabilized; this is not a significant discriminator in terms of the evaluation of the several SPS platform types.

or a more highly integrated “single CDS” approach for the overall platform.

- *SPS Communications Systems*: There are three classes of SPS communications system that are anticipated, these include: (a) on-board communications; (b) space-to-space communications; and, (c) space-to-ground communications; details include the following.
 - *On-Board Communications*: The various laser modules that would be integrated to construct this SPS concept would be largely independent in their operation, and would therefore involve relatively limited on-board communications.
 - *Space-to-Space Communications*: The highly autonomous and modular architecture of the sandwich SPS system concept will require substantial space-to-space communications, but far less than the 1979 Reference System option. The most substantial requirement will be for space-to-space communications in the proximity of each of the SPS platforms.
 - *Space-to-Ground Communications*: This SPS platform concept would require extensive space-to-ground communications from the various SPS platforms in GEO, and the various in-space transportation systems, and supporting systems (e.g., for refueling).
- *Platform-Based Space Assembly, Maintenance and Servicing Systems (SAMS) – Systems*: In the 1979 Reference SPS, there were only minimal platform-based SAMS systems – most if not all such functionality residing at substantial in-space facilities dedicated to that purpose. In the modular electric laser SPS case, the individual platform elements are relatively integrated machines, with platform self-assembly as a primary means of SAMS. Because of the large scale of key system modules, on-board SAMS might limited to on-board inspection systems and specific servicing functions (e.g., repair of wiring and harnesses, sealing leaks, examining optics / cleaning optics, etc.).

Modular Electric Laser SPS – Ground Systems. The following are the major elements that comprise the primary ground systems that support a typical SPS platform.

- WPT Ground Energy Distribution Interfaces

- *Power Grid Interface Option:* The WPT receiver – a tailored PV array – would entail a very large-scale power grid interface that could deliver up to 1,000 MW into the local power grid. The power grid interface would be consistent with large PV arrays in development and readily implemented with “smart grid” technology developments currently in progress.
- *Synthetic Fuel Production Interface(s):* A new concept that has emerged during the past several years is that of using energy delivered from an SPS to drive the production of synthetic fuels; there are several options for such an interface that apply equally to microwave and laser WPT cases, including direct thermal-chemical processing, electric power generation and utilization in electro-chemical processing and heating, and hybrid approaches.
- *SPS Mission Operations Ground Infrastructure:* SPS platforms will likely require appropriate mission operations control center infrastructure on Earth; the complexity and staffing for which will be critical to the life cycle cost (LCC) of the system. Details, particularly involving autonomous software systems and the space-based system elements will require close attention in design and development.

Supporting Systems / Infrastructure. The following are the most important systems that comprise the common supporting infrastructure for a generic SPS platform.

- *Earth-to-Orbit (ETO) Transportation:* This class of SPS system concept could involve moderate scale expendable or reusable launch systems. The scaling of this system depends strongly on the size of the module – which will likely be driven by safety requirements.
 - *ETO Launch Vehicles:* The baseline ETO launch vehicle assumed for this SPS Type is a fully reusable single-stage-to-orbit (SSTO) vehicle. (See Figure 3-3.)
 - *ETO Launch Infrastructure:* The ETO launch vehicle would require a highly coupled ground launch infrastructure that will depend on the specifics of the vehicle; including a launch pad (or runway or launch assist), fueling systems and supporting transport systems.
 - *ETO Mission Operations Ground Infrastructure:* A range of ETO related ground infrastructure will be required for the concept, analogous to the mission control center (MCC) and communications networks used by the Space Shuttle program.

- In-Space Transportation (IST)
 - *IST Vehicles:* A solar electric propulsion systems (SEPS) represents a good reusable IST solution for the challenge of large-scale deployment and maintenance of this type of SPS. An electric propulsion system that could receive WPT power from one or more SPS platforms is also possible
 - *IST Ground Support Infrastructure:* IST ground support for this SPS architecture option could be made largely autonomous using technologies now available in terrestrial applications. For specific operations, these typically autonomous systems will also require tele-supervision as appropriate; hence, ground support infrastructure must include communications elements to provide high-bandwidth communications from mission operations to one or more vehicles simultaneously.
 - *IST Mission Operations Ground Infrastructure:* As noted above, the IST system elements will of necessity require high levels of systems autonomy, combined with occasional periods of tele-supervised operation of specific vehicles.
- *IST In-Space Supporting Infrastructure:* An integrated laser SPS approach will require a number of essentially identical IST in-space supporting infrastructures; these are likely to be limited to either LEO or GEO, depending on the details of the launch and assembly sequences that may be selected.
 - *IST In-Space Refueling Platform(s):* A number of identical in-space refueling stations may be required, likely positioned in LEO but potentially also in GEO.
 - *IST SAMS Systems(s):* Because of the relatively moderate size of an individual laser SPS hardware module to be transported, the IST system could range in size from moderate scale to quite large, depending on the number of modules to be transported during a given round-trip from LEO-to-GEO-to-LEO; this design detail would entail dedicated space assembly, maintenance and servicing (SAMS) systems.
- *In-Space Infrastructure:* Supporting in-space infrastructure would be required to support the laser SPS concept, but would likely be a relatively modest element of the overall system. The principal element of such infrastructure might well entail specialized systems to service

the GEO-based laser optics systems (ala the Hubble Space Telescope Servicing missions).

- *SPS In-Space Refueling Systems(s)*: Substantial requirements for in-space refueling of the electric laser type SPS platform propulsion systems would likely be required for this concept (due to the need to support fully 3-axis stabilized ACS strategies).
- *SPS SAMS Systems(s)*: Various concepts could be involved in providing space assembly, maintenance and servicing on an ongoing basis to the “classic” type of SPS concept, including (as mentioned above) servicing for platform optics systems.

D.3.3 Characteristics of Key Supporting Systems

Modular platform electric-laser SPS concepts require smaller launch systems than 1979 Reference system type SPS, but typically larger launchers than sandwich-type SPS concepts (discussed below).

D.3.4 Concept of Operations

The modular electric laser SPS concept requires the cooperative operation of a semi-independent collection of incoherently combined laser WPT transmissions on a distributed field of bandgap tailored PV arrays. These transmissions can be shifted from one terrestrial receiver to another, but only by physically redirecting the beam expander telescopes associated with each individual electric-laser transmitter array. Launch and in-space transport require moderate-to-large scale vehicles systems due to the size of the individual SPS modular elements (see Figure D-5).

A critical issue for electric-laser SPS is to assure that the WPT system performs in a fail-safe manner. For a single platform, the configuration and operation of the various modular elements of the SPS must be incapable of being combined to achieve power levels above a certain weaponization threshold, to be determined. (This topic is discussed at greater length in the physics-based systems analysis section below.)

D.3.5 Assessment Results

Modular electric laser SPS concepts appear to be technically feasible using available technologies. However, using technologies that are currently available, electric-laser SPS concepts have a significant challenge to compete in terms of end-to-end efficiency with microwave based concepts at power levels greater than approximately 100 MW. Significant improvements in

various critical technologies (e.g., the efficiency of laser power generation) are needed to achieve acceptable levels of WPT end-to-end efficiency. In the absence of these advances, the total waste heat that must be rejected from the individual SPS platform modules could be unacceptably high; this is a major technology development challenge for the Type II SPS concept.

E.4 SPS Sandwich and Related Concepts (SPS Type III)

E.4.1 Overview

The Type III SPS option examined by the IAA study is the SPS Sandwich and related concepts, implemented with a highly modular architecture. This approach involves a light-redirection based approach to energy distribution on the SPS platform (as opposed to voltage based PMAD). It also depends upon the successful local integration of solar power generation, PMAD, and WPT systems in extremely large numbers of individual modular space systems. This architecture option includes large-scale ground based rectenna systems as receivers for the microwave power, as well as appropriate operational safety assurance systems. Figure D-6 presents a conceptual illustration of a recent sandwich-type SPS.

E.4.2 Architecture Details

At an overall level, SPS Sandwich-type concepts and similar approaches are extreme in the degree of modularity involved in almost all components of the system – but, especially in the solar power / WPT transmission structural system. The concept involves several architecture details that are similar to laser-type SPS concepts, but at much greater levels of modularity.

These concepts have few similarities at the architecture level with the 1979 SPS Reference System family of concepts. Figure D-7 presents an end-to-end illustration of a Sandwich-type SPS system concept.

Modular Sandwich Type SPS – Primary Platform Systems. The following are the major elements that comprise the primary systems of a generic SPS platform (including the end-to-end wireless power transmission system).

- *Solar Power Generation (SPG):* The SPG systems for a hyper-modular sandwich-type SPS strongly prefers a high-efficiency technical solution, such as a multi-bandgap approach. The system as noted is locally

integrated with SPG, PMAD and WPT elements all located within less than 0.1-10.0 meters distance, depending on the specific concept.

Figure D-6 Conceptual Illustration of an Recent Sandwich-Type SPS

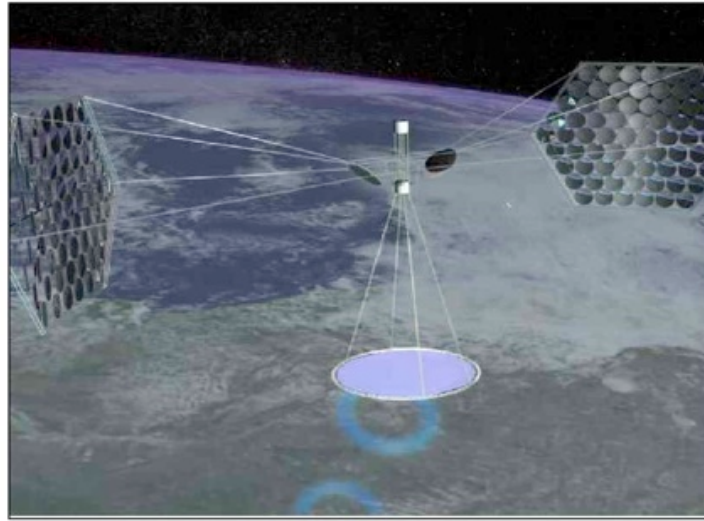

Credit: Concept by John Mankins; Art by Kris Holland / Mafic Studios c. 2007

Figure D-7 End-to-End Concept of a Sandwich-type SPS

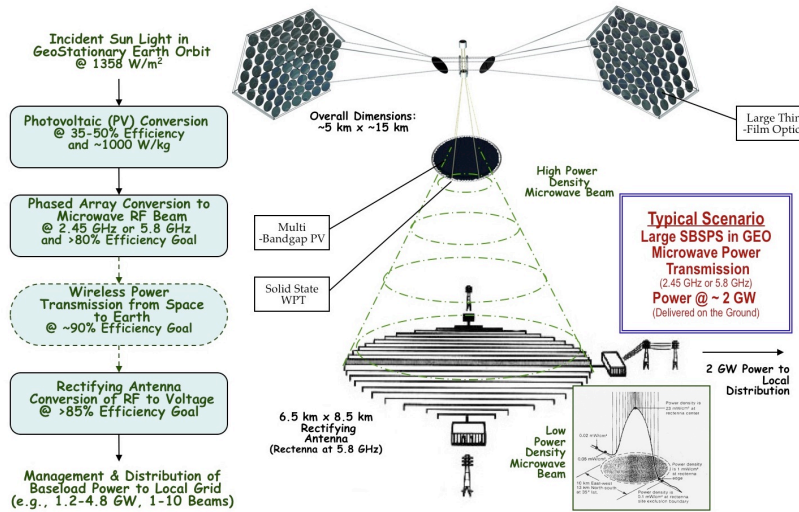

Credit: Concept by John Mankins; Art by Mafic Studios and Artemis Innovation Management Solutions LLC

- *SPG - Power Management and Distribution (PMAD)*: The PMAD subsystem for this systems approach is local in character (as noted above), and would typically operate at low voltages, consistent with direct connections from the SPG to the WPT subsystems.
- *SPG - Thermal Management Systems (TMS)*: The SPG thermal management systems (SPG-TMS) for a modular sandwich SPS must be capable of removing large amounts of heat from across the face of the transmitter system. The thermal load will depend directly on the power to be delivered from each portion of the SPG “backplane” of the sandwich array.
- *SPG - Solar Energy Optical Systems*: In the case of a concentrator PV (CPV) approach to SPG that includes multibandgap solar cells, a local solar energy optical system would probably be employed.
- *Platform PMAD System*: In the case of the Sandwich SPS, there is only a relatively minimal on-board PMAD system separate from that of the SPG-PMAD-WPT panels of the platform. This residual PMAD system would provide power distribution for various ancillary functions, such as attitude control and GN&C, propulsion, communications, etc.
 - *Platform PMAD - Thermal Management Systems (TMS)*: As noted, the non-sandwich PMAD system for this type of SPS would be comparatively modest; similarly, the heat rejection requirements for the PMAD-TMS would be individually similar to conventional spacecraft systems. However, there would be issues associated with the view available for heat rejection due to the various large objects on the platform (e.g., the sandwich structure, the optical systems, etc.)
- *Wireless Power Transmission System (WPT) – On-Board Transmitter*: The on-board WPT transmitter for an SPS of the sandwich type would be a high-efficiency solid state transmitter approach, involving FET amplifiers and local phase shifter circuitry integrated into a very large number of retro-directive phased array systems; these would be integrated into a large-scale, semi-rigid planar structure approximately 1,000 meters in diameter.
 - *WPT - PMAD*: The wireless power transmission system PMAD subsystem for this SPS approach is local in character (as noted

- previously), and would typically operate at low voltages, consistent with direct connections from the WPT to the SPG subsystems.
- *WPT – TMS*: The WPT thermal management systems (WPT-TMS) for a modular sandwich SPS must be capable of removing large amounts of heat from across the face of the transmitter system. The thermal load will depend directly on the power transmitted from each portion of the transmitter array. This system must
 - *WPT System – Ground Receiver*: The WPT ground receiver for SPS concepts of the RF sandwich-type would be a rectifying antenna (a “rectenna”), consisting of a very large number of distinct antenna elements, selected filters to reduce harmonics, high-efficiency diodes and a wiring harness to deliver the resulting DC current from the rectenna. For the baseline case, operating at a frequency of 2.45 GHz, the ground-based rectenna was in the shape of an ellipse with an East-West diameter of approximately 10 km, and a North-South diameter that would depend upon the Latitude at which the rectenna was located. For higher frequencies (e.g., 5.8 GHz), the size of the received RF “spot” on Earth would scale linearly – according to the equation provided in Section 7. Depending on the details of the local context, this receiver might be placed within 100 km or less of the principal market(s) to be served.
 - *WPT Pilot Signal Systems*: A highly promising approach to microwave power transmission involves the use of a retro-directive phased array beam control system; this approach entails the use of a pilot signal, transmitted from the location of the WPT receiver, which would provide phase information across all of the elements of the WPT transmitter. A typical frequency at which the pilot signal would be transmitted would be exactly 50% of the frequency of the power transmission (e.g., if the transmitter operates at 2.45 GHz, the pilot signal would be transmitted at 1.225 GHz); however, other options are possible.
 - *WPT Beam Safety Systems*: An assured fail-safe, multi-tiered beam safety architecture and system is essential to the future deployment of SPS. The three tiers that are typically discussed include (1) physical isolation of the beam receiver so that under normal operations the beam intensity outside the boundaries of the receiving facility are below local beam intensity jurisdictional

restrictions (e.g., in watts/meter²); (2) active feedback from the ground to the platform in space to authorize transmission (preferable with strong encryption); and, (3) a real-time beam cut-off system to stop the transmission as may be necessary in very short times. In the case of a sandwich-type SPS with retro-directive phase control, the SPS WPT system has the additional safety feature that focusing the RF energy toward any point on Earth may not be enabled without a pilot signal from site of the receiver.

Modular Sandwich Type SPS – Secondary Platform Systems. The following are the most significant elements that constitute the secondary in-space systems of a generic SPS platform.

- *Platform Structural Systems:* The primary platform structural systems for this SPS concept are integral with the sandwich structure itself. These systems must be semi-rigid, however they would not require the degree of rigidity of the precision waveguide structure involved in an electron tube approach (due to capability of the solid state retro-directive system to compensate for modest physical displacements of the sandwich structure).
- *Guidance, Navigation and Control (GN&C) / Attitude Control Systems (ACS):* The modular RF symmetrical sandwich SPS platform type embodies a hybrid GN&C approach, including elements of a 3-axis stabilized system, gravity gradient stabilization, and control through the use of solar photon pressure. The required GN&C and ACS systems may be expected to require complex interactions, requiring substantial software development and on-board processing. The ACS system would be required to work in complete tandem with various platform propulsion system elements.
- *Platform Propulsion Systems:* The critical requirement that all GEO-based SPS platform propulsion systems must satisfy is for north-south station-keeping (NSSK) to compensate for various torques on the orbital position of the platform due to forces such as the gravitational pull of the Sun, the Moon and the major planets. For a satellite in GEO, this requirement is for an annual change in velocity of approximately 50 meters per second. The propellant mass necessary to accommodate this adjustment will depend upon the type of propulsion system used (e.g., chemical versus electrical, etc.).

- *Command & Data Systems (CDS)*: CDS systems for a modular sandwich SPS concept could require a novel, highly distributed family of more-or-less standard spacecraft data systems (i.e., multiple copies of a monolithic command and data system approach for each of the platform modules in the overall SPS) operating in a coherent CDS approach for the overall platform.
- *SPS Communications Systems*: There are three classes of SPS communications system that are anticipated, these include: (a) on-board communications; (b) space-to-space communications; and, (c) space-to-ground communications; details include the following.
 - *On-Board Communications*: The sandwich SPS system concept is a highly intelligent, modular approach, in which all of the elements must work in cooperation to successfully generate a single coherent RF beam. This concept would entail a very high degree of on-board systems intelligence and potentially significant on-board communications traffic.
 - *Space-to-Space Communications*: The highly autonomous and modular architecture of the sandwich SPS system concept will require substantial space-to-space communications, but far less than the 1979 Reference System option. The most substantial requirement will be for space-to-space communications in the proximity of each of the SPS platforms.
 - *Space-to-Ground Communications*: This SPS platform concept would require extensive space-to-ground communications from the various SPS platforms in GEO, and the various in-space transportation systems, and supporting systems (e.g., for refueling).
- *Platform-Based Space Assembly, Maintenance and Servicing Systems (SAMS) – Systems*: One of the defining characteristics of the modular Sandwich type SPS is the utilization of extensive platform-based SAMS systems – with little of such functionality residing at dedicated in-space facilities. Such capabilities would likely entail a number of specialized robotic elements as well as built-in NDE / NDI functionality.

Modular Sandwich Type SPS – Ground Systems. The following are the major elements that comprise the primary ground systems that support a typical SPS platform.

- *WPT Ground Energy Distribution Interfaces:*
 - *Power Grid Interface.* Power Grid Interface: The WPT receiving rectenna would require a very large-scale power grid interface that could deliver typically from 1,000 MW to 3,000 MW of power received into the local power grid. Other than the scale of power delivered, the power grid interface should be readily implemented with “smart grid” technology developments currently in progress.
 - *Synthetic Fuel Production Interface(s):* A new concept that has emerged during the past several years is that of using energy delivered from an SPS to drive the production of synthetic fuels; there are several options for such an interface that apply equally to microwave and laser WPT cases, including direct thermal-chemical processing, electric power generation and utilization in electro-chemical processing and heating, and hybrid approaches.
- *SPS Mission Operations Ground Infrastructure:* SPS platforms will likely require appropriate mission operations control center infrastructure on Earth; the complexity and staffing for which will be critical to the life cycle cost (LCC) of the system. Details, particularly involving autonomous software systems and the space-based system elements will require close attention in design and development.

Supporting Systems / Infrastructure. The following are the most important systems that comprise the common supporting infrastructure for a generic SPS platform.

- *Earth-to-Orbit (ETO) Transportation:* This class of SPS system concept would be optimized for moderate scale reusable launch systems. The specific scaling of this system depends somewhat, but not strongly on the size of the module – which will likely be driven by thermal requirements.
 - *ETO Launch Vehicles:* The baseline ETO launch vehicle assumed for this SPS Type is a fully reusable single-stage-to-orbit (SSTO) vehicle. (See Figure 3-3.)
 - *ETO Launch Infrastructure:* The ETO launch vehicle would require a highly coupled ground launch infrastructure that will depend on the specifics of the vehicle; including a launch pad (or runway or launch assist), fueling systems and supporting transport systems.

- *ETO Mission Operations Ground Infrastructure:* A range of ETO related ground infrastructure will be required for the concept, analogous to the mission control center (MCC) and communications networks used by the Space Shuttle program.
- In-Space Transportation (IST)
 - *IST Vehicles:* A solar electric propulsion systems (SEPS) represents a good reusable IST solution for the challenge of large-scale deployment and maintenance of this type of SPS. An electric propulsion system that could receive WPT power from one or more SPS platforms is also possible
 - *IST Ground Support Infrastructure:* IST ground support for this SPS architecture option could be made largely autonomous using technologies now available in terrestrial applications. For specific operations, these typically autonomous systems will also require tele-supervision as appropriate; hence, ground support infrastructure must include communications elements to provide high-bandwidth communications from mission operations to one or more vehicles simultaneously.
 - *IST Mission Operations Ground Infrastructure:* As noted above, the IST system elements will of necessity require high levels of systems autonomy, combined with occasional periods of tele-supervised operation of specific vehicles.
- *IST In-Space Supporting Infrastructure:* An modular sandwich type SPS approach will likely require a number of essentially identical IST in-space supporting infrastructures; these are likely to be based in or near LEO, rather than in GEO, however the details will depend upon the launch and assembly sequences that may be selected.
 - *IST In-Space Refueling Platform(s):* A number of identical in-space refueling stations may be required, likely positioned in LEO but potentially also in GEO. (If the propulsion systems of the IST and the SPS platform itself can be identical in terms of refueling and propellants, this could represent a cost savings for the architecture.)
 - *IST SAMS Systems(s):* Because of the small size of a typical microwave sandwich type SPS hardware module to be transported, the IST system could range in size from small to moderate to quite large, depending on the number of modules to be transported

during a given round-trip from LEO-to-GEO-to-LEO; this design detail would entail dedicated space assembly, maintenance and servicing (SAMS) systems.

- *In-Space Infrastructure*: Only relatively modest supporting in-space infrastructure would be required to support the RF sandwich type SPS concept, but would likely be a modest element of the overall system. The principal component of such infrastructure might entail specialized systems to service the SPS large, thin-film optical systems; depending on detailed design studies.
 - *SPS In-Space Refueling Systems(s)*: There would be a need for in-space refueling of the modular sandwich type SPS platform propulsion systems; design studies will be required to determine the degree to which the system could be gravity gradient stabilized. In-space refueling would likely be required for this concept (due to the need to support fully 3-axis stabilized ACS strategies).
 - *SPS SAMS Systems(s)*: Various concepts could be involved in providing space assembly, maintenance and servicing on an ongoing basis to the sandwich type of SPS concept; however these are expected to be integrated to the platform; one exception may be servicing for large, thin-film optical systems for solar energy collection and redirection.

D.4.3 Characteristics of Key Supporting Systems

The family of SPS concepts based on a modular version of the Sandwich approach requires substantially lesser amount of supporting in-space infrastructure than the Type I (Classic) concepts developed earlier. As described above, these system-of-systems elements include primarily identical in-space transportation systems. The ETO transportation system requirements appear more flexible than other options, allowing launch of Type III SPS components on a wide variety of vehicle sizes. The facilities required to support these launchers should be capable of dual-purpose operations (i.e., launch of payloads for markets other than SPS assembly).

D.4.4 Concept of Operations

The concept of operations (CONOPS) for the Type III SPS is based on highly autonomous, largely-self-sufficient modular systems (analogous to insect-class intelligence, operating in groups within a structured environment), and requires a relatively modest number of systems in

addition to those on the SPS platform itself. Generally speaking, the platform concepts involve large numbers of modular system elements that will require either ground-based or platform-based command and control architectures.

D.4.5 Assessment Results

The modular Sandwich-type microwave SPS concepts appear to be technically feasible using available technologies. Available microwave devices have good efficiencies (e.g., 50%-70%), however improvements are needed to achieve acceptable levels of WPT end-to-end efficiency and cost of power. Although design alternatives exist, the local waste heat that must be rejected from the individual SPS sandwich modules at the center of the transmitter (in the case of a Gaussian Distribution) could be unacceptably high; this is a major technology development challenge for the Type III SPS concept.

APPENDIX E

TECHNOLOGY READINESS AND RISK ASSESSMENT

The following appendix provides detailed information concerning the space solar power technology readiness and risk assessment that was performed. The appendix is organized into two sections: (1) a discussion of the TRRA methodology and detailed definitions that were used; and, (2) elaboration of the detailed TRRA results that provided the foundation for the high-level results presented in Chapter 4.

E.1 Technology Readiness and Risk Assessment Methodology

The following tools are used in this report to provide an integrated and consistent assessment of both technology maturity and risk: (1) the standard Technology Readiness Levels (TRLs), and (2) the Research and Development Degree of Difficult (R&D3) Scale. A key issue in assessing both the systems concepts and the technologies used is the identification of how critical a particular technology R&D effort – including FOMs to be achieved and operating environment – is to a particular SPS system concept. In the IAA study report, the evaluation of this factor is summarized as the “Technology Need Value” scale (“TNV”). All three of these R&D management metrics are described in sections that follow.

E.1.1 Technology Readiness Levels

E.1.1.1 TRL Definitions. As a standard, technology discipline-independent terminology for the identification of the current and projected level of maturity for a particular technology, NASA and the DOD in the US, as well as the European Space Agency (ESA) and the Canadian Space Agency (CSA) and CNES (the French space agency) use the TRL (technology readiness level) scale.^{lii} The following are the standard definitions of the TRL scale, as used in the body of this report (concerning the assessment of Space Solar Power and related technology).

E.1.1.2 ΔTRL. The Delta-TRL (Δ TRL) is simply the difference in TRL's between the current level of maturity of a particular technology and the TRL desired by a particular point in time in the future. For example, if the desired TRL is TRL-6 and the current TRL is TRL-3, the Delta-TRL is

$\Delta\text{TRL}=3$. In this example, $\Delta\text{TRL}=3$ corresponds the challenge of technology that is currently in the laboratory, proof-of-concept level (TRL=3) and which must advance to a system-level prototype demonstration in a operationally-relevant environment (TRL=6). Each step represents another level of developmental maturity – hence, more steps is equivalent to greater R&D uncertainty over a given length of time.

Table E.1 Standard TRL Definitions

READINESS LEVEL	DEFINITION	EXPLANATION
TRL 1	Basic principles observed and reported	Lowest level of technology readiness. Scientific research begins to be translated into applied research and development.
TRL 2	Technology concept and/or application formulated	Once basic principles are observed, practical applications can be invented and R&D started. Applications are speculative and may be unproven.
TRL 3	Analytical and experimental critical function and/or characteristic proof-of-concept	Active research and development is initiated, including analytical / laboratory studies to validate predictions regarding the technology.
TRL 4	Component and/or breadboard validation in laboratory environment	Basic technological components are integrated to establish that they will work together.
TRL 5	Component and/or breadboard validation in relevant environment	The basic technological components are integrated with reasonably realistic supporting elements so it can be tested in a simulated environment.
TRL 6	System/subsystem model or prototype demonstration in a relevant environment (ground or space)	A representative model or prototype system is tested in a relevant environment.
TRL 7	System prototype demonstration in a space environment	A prototype system that is near, or at, the planned operational system.
TRL 8	Actual system completed and "flight qualified" through test and demonstration (ground or space)	In an actual system, the technology has been proven to work in its final form and under expected conditions.
TRL 9	Actual system "flight proven" through successful mission operations	The system incorporating the new technology in its final form has been used under actual mission conditions.

E.1.2 Research and Development (R&D) Degree of Difficulty

A measure of how much difficulty can be expected in the maturation of a particular technology can be very useful as a complement to the standard TRL scale. TRL's are a systematic, non-discipline specific metric/measurement system that supports assessments of the maturity of a particular technology and the consistent comparison of maturity between different types of technology. Another measure — the “Research and Development Degree of Difficulty” (R&D³) — is a measure of the riskiness (probability of success and/or failure) of the planned technology development effort.^{liii} See Figure E.1. The following paragraphs provide the definitions of each of the levels in the R&D³ scale.

Figure E.1 Research and Development (R&D) Degree of Difficulty (R&D³)

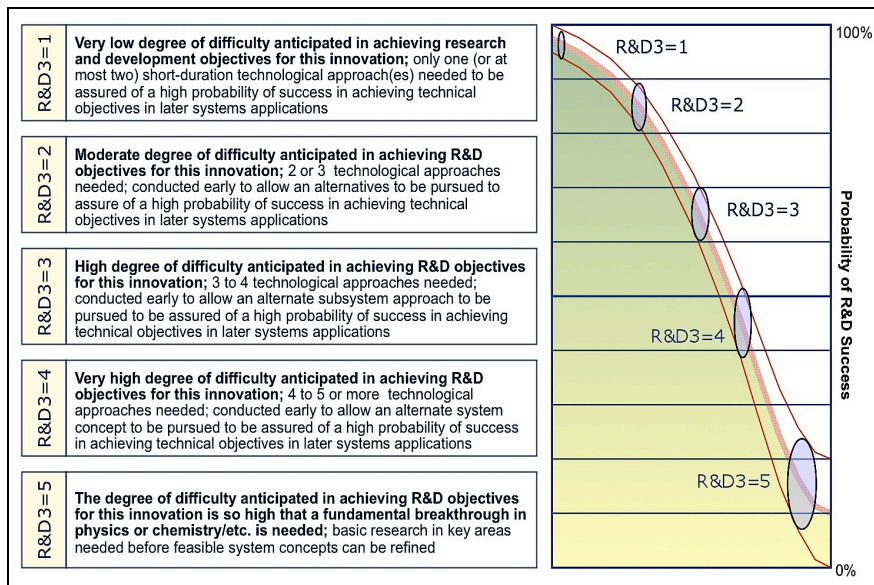

R&D³ = 1. An R&D³ of “1” corresponds to an expected degree of difficulty in achieving research and development objectives that is low; in other words, the probability of success is high enough to assure that with only one or two alternative technological approaches a given program can realize a high probability of achieving a given set of R&D objectives. Generally speaking, an R&D³ of 1 would correspond with moderate to high

level of TRL; however, there may be cases in which a low TRL technology could have an R&D³ of “1” because the R&D path requires no obvious technical hurdles, special facilities, or unusual testing environments.

R&D³ = 2. An R&D³ of “2” reflects a no more than a moderate expectation of difficulty in achieving research and development objectives. Not less than two or three alternative technological approaches should be pursued, if a given program wishes to have a high probability of achieving a given set of R&D objectives. Generally speaking, an R&D³ of 2 would correspond with a moderate to higher level of TRL, although there may be cases in which lower TRL technologies reflect an R&D³ of “2” due to details of expected R&D.

R&D³ = 3. An R&D³ of “3” corresponds to an expected degree of difficulty in achieving research and development objectives that is high enough that substantial R&D is needed. As a result, if a given program wishes to have a high probability of achieving a given set of R&D objectives, then not less than three or four technological approaches need to be pursued. In this case, applied research may be needed before detailed designs for technically feasibility system concepts can be developed. Generally speaking, an R&D³ of 3 corresponds with a low to moderate value of TRL.

R&D³ = 4. An R&D³ of “4” represents the expectation that there will be a very high degree of difficult in achieving research and development objectives. As a result, if a given program wishes to have a high probability of achieving a given set of R&D objectives, then not less than four or five technological approaches need to be pursued. Also, in this case R&D should be conducted early enough to allow for significantly different alternative system concepts to be pursued based on the results of the R&D effort. Generally speaking, an R&D³ of 4 would correspond with a low value to moderate value of TRL.

R&D³ = 5. An R&D³ of “5” corresponds to an expected degree of difficulty in achieving research and development objectives that is so extremely high that a fundamental breakthrough in physics, chemistry, etc., is required. In this case, basic research is clearly needed before technically feasibility system concepts can be defined in detail. Generally speaking, and R&D³ of 5 corresponds with a very low value of TRL.

E.1.3 Technology Need Value

The Technology Need Value (TNV) is a measure of the importance of a particular technology (including a specific set of figures of merits) to one or more specific system concepts in a targeted application.

Some of the technologies applied in a specific concept are critical to the functional characteristics of the concept; these are “enabling”. Other technologies are simply “enhancing” to varying degrees and might be replaced with other technologies with only modest changes to the performance, cost, etc., of the system to be developed. The Technology Need Value (TNV) is a qualitative measure of this factor. The three TNV values used in the ITAM include the following.

TNV-1. In the case of a TNV of “1”, the technology R&D effort *is not critical at this time* to the success of the program—the advances to be achieved are useful for some cost improvements; however, the information to be provided is not needed for management decisions until the far-term.

TNV-2. A TNV of “2” represents a technology effort that is *useful* to the success of the program—the advances to be achieved would meaningfully improve cost and/or performance; however, the information to be provided is not needed for management decisions until the mid- to far-term.

TNV-3. For a TNV of “3”, the technology effort is important to the success of the program—the advances to be achieved are important for performance and/or cost objectives and the information to be provided is needed for management in the near- to mid-term.

TNV-4. A TNV of “4” corresponds to a case in which the technology effort is very important to the success of the program; the advances to be achieved are enabling for cost goals and/or important for performance objectives and the information to be provided would be highly valuable for near-term management decisions.

TNV-5. The technology effort is critically important to the success of the program at present—the performance advances to be achieved are enabling and the information to be provided is essential for near-term decisions.

E.2 SSP Technology Readiness and Risk Assessment Detailed Results⁵⁶

E.2.1 SPS Concept Specific Technologies

E.2.1.1 Wireless Power Transmission TRRA Results. Key technologies for the primary WPT system options include (1) electron tube RF generating devices (such as magnetrons, gyrotrons, TWTs, etc.); (2) solid state RF generating devices (such as FET amplifiers); and (3) solid state laser generative devices (such as laser diode arrays). Other key component technologies include (for the solid state RF case), phase shifters, antennas,

⁵⁶ Note: where shown in one of the TRRA tables, “CD” refers to “concept dependent”

etc. (See Chapter 4 for the FOMS.) The following table (Table E-2) presents the results of a preliminary assessment of key technology options.

Table E-2 Results of Preliminary SPS WPT Technology Assessment

TECHNOLOGY REQUIREMENT		SYSTEM APPLICATION				TRL	R&D3
TECHNOLOGY TOPIC	SUB-TOPIC	Type-I SSP TNV	Type-II SSP TNV	Type-III SSP TNV	Other SSP TNV / Type		
RF WPT Transmission	Electron Tubes	3-4	1	1-2	2-3	5-6	1-2
	Solid State Amplifiers	1-2	1	4-5	2-3	4-5	1-2
Laser WPT Transmission	Diode Laser Array	1	5	1	1-2	3-4	3-4
	Solar-Pumped Laser	1	2-3	1	2-3	2	4-5
	Laser WPT Optical Systems	1	5	1	1-2	3-4	1-2
WPT Beam Steering	Mechanical Pointing (Coarse)	3-4	4-5	1	2-3	2-3	3-4
	Mechanical Pointing (Fine)	1	4-5	1	2-3	2-3	3-4
	Local Solid State Phase Shifters	1-2	1	4-5	2-3	4-5	1-2
	Electron Tube Phase Control	3-4	1	1	2-3	2-3	2-3

E.2.1.2 Solar Power Generation TRRA Results. There are a number of key technologies involved in solar power generation for future SPS platforms; these include: (1) multi-bandgap PV cells; (2) thin-film PV cells; and (3) conventional Si PV cells. Various associated component technologies include concentrator (and other) SPG optical systems, cell-level power management and distribution, cell supporting structural systems, cell-level thermal management systems, and others. For some architectural cases, other technology options include solar dynamic power conversion options (e.g., Sterling engines, Rankine Cycle engines, Brayton Cycle engines, etc.) See Chapter 4 for the key FOMS. The following table

(Table E-3) presents the results of a preliminary assessment of key technology options for SPS solar power generation systems.

Table E-3 Results of Preliminary SPS SPG Technology Assessment

TECHNOLOGY REQUIREMENT		SYSTEM APPLICATION				TRL	R&D3
TECHNOLOGY TOPIC	SUB-TOPIC	Type-I SSP TNV	Type-II SSP TNV	Type-III SSP TNV	Other SSP/TNV Type		
Photovoltaic Solar Power Generation	Thin-Film PV	4-5	2-3	1	CD	3-4	2-3
	Multi-bandgap Photovoltaics	2-3	2-3	4-5	CD	3-4	2-3
	Conventional Silicon PV	2-3	2-3	1	CD	3-4	2-3
Solar Dynamic Solar Power Gen.	Sterling Solar Dynamic	4-5	2-3	1	CD	3-4	2-3
	Brayton Cycle Solar Dynamic	4-5	2-3	1	CD	3-4	2-3
Supporting Systems Tech.	Concentrator Optical Systems	1-2	2-3	4-5	CD	3-4	2-3
	SPG Thermal Mgt. Systems	1-2	3-4	4-5	CD	2-3	2-3

E.2.1.3 Power Management and Distribution TRRA Results. The major technology areas in the general category of power management and distribution include: (a) high voltage power cabling, (b) modular / intelligent power conversion, and (c) advanced power management options (e.g., superconductors); as indicated in the discussion of generic SPS system architectures in Chapter 2, these functional areas of PMAD technology may be further parsed into PMAD and TMS involved with SPG, the platform, or WPT, etc., depending on the specific SSP system concept under examination. See Chapter 4 for the key PMAD FOMS. The following table (Table E-4) presents the results of a preliminary assessment of key technology options for PMAD.

Table E-4 Results of Preliminary SPS PMAD Technology Assessment

TECHNOLOGY REQUIREMENT		SYSTEM APPLICATION				TRL	R&D3
TECHNOLOGY TOPIC	SUB-TOPIC	Type-I SSP TNV	Type-II SSP TNV	Type-III SSP TNV	Other SSP TNV / Type		
PMAD - Cabling	Low-Voltage Power Cabling	1-2	1-2	4-5	CD	5-6	1-2
	Moderate- to High-Voltage Cabling	2-3	3-4	1-2	2-3	4-5	2-3
	Very High Voltage Power Cabling	4-5	1	1	3-4	2	4-5
	Superconducting Power Cabling	2-3	1-2	1	2-3	1-2	3-4
	High-Temp. Super-conductor Cabling	2-3	1-2	1	2-3	1-2	3-4
PMAD – Power Management	High Voltage Power Management	4-5	2-3	1-2	1-2	2-3	3-4
	High Voltage Rotary Coupling PMAD	4-5	1	1	1-2	1-2	4-5
	Modular / Intelligent Power Management	2-3	3-4	4-5	2-3	3-4	1-2
	Superconducting Power Management	1-2	1-2	1	2-3	2-3	3-4

E.2.1.4 Thermal Management Systems TRRA Results. The major technology areas in the general category of thermal management systems include: (a) radiators, (b) thermal coatings, (c) active cooling (e.g., refrigeration), (d) thermal loops and heat pipes, and (e) advanced thermal management options (e.g., thermo-electric cooling, micro-channel cooling, etc.). As indicated in the discussion of generic SPS system architectures in Chapter 2, these functional areas of technology may be further parsed into TMS involved with SPG, the platform, or WPT, etc., depending on the specific SSP system concept that is being examined. See Chapter 4 for the

key TMS FOMS. The following table (Table E-5) presents the results of a preliminary assessment of key technology options for SPS TMS systems.

Table E-5 Results of Preliminary SPS TMS Technology Assessment

TECHNOLOGY REQUIREMENT		SYSTEM APPLICATION				TRL	R&D3
TECHNOLOGY TOPIC	SUB-TOPIC	Type-I SSP TNV	Type-II SSP TNV	Type-III SSP TNV	Other SSP TNV / Type		
Thermal Mgt Systems	High-Temperature & Capacity Radiators	4-5	4-5	1	CD	2-3	2-3
	Low-/Mod-Temp. & Capacity Radiators	1-2	2-3	4-5	2-4	4-5	2-3
	Thermal Coatings & Surface Modification	2-3	2-3	2-3	2-3	3-4	2-3
	Active Cooling & Refrigeration Syst.	1-2	3-4	2-3	CD	3-4	3-4
	Thermal Loops & Heat Pipes	2-3	2-3	3-4	2-4	3-4	2-3
Advanced TMS Options	Thermo-electric Cooling	1-2	1-2	2-3	CD	2-3	2-3
	Micro-channel Cooling	1-2	1-2	2-3	CD	4-5	2-3
	High-Temperature Materials	2-3	4-5	2-3	CD	2-3	2-3
	"Super" Heat Pipe Systems	2-3	2-3	2-3	2-3	2-3	3-4

E.2.3 Platform Generic Technologies TRRA Results

There are a number of key technologies involved in performing the full range of generic platform functions for future solar power satellites; these include: (1) large, lightweight structural systems; (2) in-space assembly & construction (ISAAC), including robotics and interfaces; (3) modular GN&C and/or avionics; (4) modular command and communications; (5) high-efficiency / radiation-tolerant electronics, PV and related systems; and, (6) systems autonomy.

Note that in the case of space structural systems, there will be a wide range of types of structures and materials that will be required for each of the SPS concepts under consideration due the exceptionally large and complex character of the platforms involved; hence no single technology will be sufficient to enable SPS to be development and deployed successfully. See Chapter 4 for the key FOMS for platform generic technologies.

The following table (Table E-6) presents the results of a preliminary assessment of key options for SPS Generic Platform technologies.

Table E-6 Results of Preliminary SPS Platform Technology Assessment

TECHNOLOGY REQUIREMENT		SYSTEM APPLICATION				TRL	R&D3
TECHNOLOGY TOPIC	SUB-TOPIC	Type-I SSP TNV	Type-II SSP TNV	Type-III SSP TNV	Other SSP TNV / Type		
Space Structural Systems	Large area, low mass membranes	2-3	2-3	4-5	CD	2-3	2-3
	Kinematically-deployed structures	3-4	3-4	3-4	CD	4-5+	1-2
	Inflation-deployed structures	2-3	2-3	2-3	CD	2-3	2-3
	Low-mass reliable interconnects	4-5	4-5	4-5	4-5	2-3	1-2
	Active Structures / CSI	4-5	4-5	4-5	4-5	4-5	2-3
	Light-Weight / Durable Materials	4-5	4-5	4-5	4-5	3-4	2-3
	Adv. Structural Concepts	2-3	4-5	4-5	CD	2-3	2-3
	Adv. Materials (e.g., CNTs)	2-3	2-3	2-3	CD	2-3	3-4
In-Space Assy & Construction	Actively controlled interconnects	2-3	4-5	4-5	CD	2-3	2-3

TECHNOLOGY REQUIREMENT		SYSTEM APPLICATION				TRL	R&D3
TECHNOLOGY TOPIC	SUB-TOPIC	Type-I SSP TNV	Type-II SSP TNV	Type-III SSP TNV	Other SSP TNV / Type		
	Auto. Rendezvous & Docking	2-3	4-5	4-5	CD	4-5+	1-2
	Affordable Modular Robotics	2-3	2-3	4-5	CD	4-5	2-3
Avionics and Electronics	Modular / Cooperative GN&C	2-3	2-3	4-5	CD	4-5	2-3
	High Efficiency Solid State Devices	1-2	4-5	4-5	CD	2-3	2-3
Command and Communications	Wireless On-Board / Reconfigurable Communications	1-2	4-5	4-5	CD	3-4	1-2
	Adv Space-to-Ground Comm.	4-5	4-5	4-5	4-5	4-5+	1-2
Systems Autonomy	On-Board Platform Autonomy	4-5	4-5	4-5	4-5	4-5+	1-2
	Ground Mission Ops Autonomy	4-5	4-5	4-5	4-5	4-5+	1-2
Component Interconnects	See In-Space Assembly and Construction						

E.2.4 Key SPS Supporting Systems Technologies

The large number of systems and technologies required to support SPS deployment and operations comprises a daunting prospect. As a consequence, the following sections provide no more than identification and a cursory assessment of the most important technology options.

E.2.4.1 ETO Transportation TRRA Results. Future development of highly affordable and low-risk Earth-to-orbit (ETO) transportation systems is essential for most, if not all, ambitious future commercial development of space opportunities. And, of course, low-cost ETO transport is critical to

the economic viability of full-scale SPS systems designed to deliver power into commercial terrestrial markets in the mid- to long- term. Not surprisingly, low-cost ETO transport will require the development, maturation and deployment of a number of new technologies.

This technology assessment comprises only a few of the specific R&D areas that may be needed to realize low-cost and highly reliable ETO for SPS (and, not all of these are required simultaneously for all types of reusable launch vehicles; “RLVs”). These capabilities include: (1) High-thrust advanced cryogenic rocket engines (ACRE) with large operational margins (e.g., using advanced materials components); (2) moderate thrust-to-weight rocket-based combined cycle (RBCC) or turbine-based combined cycle (TBCC) propulsion with large operational margins; (3) lightweight, 1000 flight class vehicle airframes; (4) durable, 1000 flight class thermal protection systems (TPS), (5) airplane class avionics and flight operations; (6) low-cost high-flight rate launch assist systems; and, (7) advanced launch concepts (e.g., maglev to orbit type concepts).^{lv} The following table (see Table E-7 below) presents the results of a preliminary assessment of key technology options.

E.2.4.2 Affordable In-space Transportation TRRA Results. Almost as much as low-cost ETO transport, affordable and timely in-space transportation will be essential to a number of ambitious options for the future commercial development of space. This is particularly true for SPS options, in which all SPS systems and consumables must be transported from LEO to GEO for deployment.⁵⁷ In addition to the transportation system, there are also a number of key supporting infrastructures that are enabling for AIST. For example, cryogenic propellant depots (CPDs), employing cryogenic fluid management (CFM) technology, are one critical systems-level technology for architectures that include high-energy cryogenic propulsion systems. The following table (see Table E-8) presents the results of a preliminary assessment of key technology options.

⁵⁷ This is certainly the case prior to the potential introduction of extraterrestrial materials.

Table E-7 Results of Preliminary SPS ETO Technology Assessment

TECHNOLOGY REQUIREMENT		SYSTEM APPLICATION				TRL	R&D3
TECHNOLOGY TOPIC	SUB-TOPIC	Type-I SSP TNV	Type-II SSP TNV	Type-III SSP TNV	Other SSP TNV / Type		
Adv. Propulsion Systems	High-Thrust/Margin Rocket Propulsion	3-4	2-3	1-2	2-3	4	2-3
	High Margin Combined Cycle Propulsion	1	1-2	2-3	2-3	4	2-3
Long-Lived Vehicle Systems	1000 Flight Class Vehicle Airframes	4-5	4-5	4-5	4-5	4	2-3
	1000 Flight Class Vehicle TPS	4-5	4-5	4-5	4-5	4	2-3
	Airplane Like Avionics & Ops	4-5	4-5	4-5	4-5	4-5	1-2
Launch Assist Systems	MagLifter Type Launch Assist	1	1	2-3	2-3	4-5	1-2
Advanced Vehicle Systems	StarTram Type EM ETO Systems	1	1	2-3	2-3	3-4	2-3

Table 4-8 Results of Preliminary SPS AIST Technology Assessment

TECHNOLOGY REQUIREMENT		SYSTEM APPLICATION				TRL	R&D3
TECHNOLOGY TOPIC	SUB-TOPIC	Type-I SSP TNV	Type-II SSP TNV	Type-III SSP TNV	Other SSP TNV / Type		
High-Thrust Transportation	Cryogenic Propulsion	1-2	1-2	1-2	CD	5-6	1-2
	Aerobraking Systems	1-2	1-2	1-2	CD	3-4	2-3
Low-Thrust Transportation	Electric Propulsion Systems	4-5	4-5	4-5	CD	4-5	1-2

TECHNOLOGY REQUIREMENT		SYSTEM APPLICATION				TRL	R&D3
TECHNOLOGY TOPIC	SUB-TOPIC	Type-I SSP TNV	Type-II SSP TNV	Type-III SSP TNV	Other SSP TNV / Type		
	High-Power / Moderate-Voltage Solar Power Gen.	4-5	4-5	4-5	CD	4-5	1-2
AIST Supporting Systems	Propellant Depot(s)	2-3	2-3	2-3	CD	3-4	2-3
	Logistics / Materiel Handling Systems	4-5	4-5	4-5	CD	4-5	1-2

E.2.4.3 In-Space Assembly, Maintenance and Servicing TRRA Results.
 In-Space Assembly, Maintenance and Servicing (ISAMS) is another area of space technology that is going to be essential to numerous ambitious future commercial development of space. This is certainly true for exceptionally large solar power satellites, which will entail unprecedented levels of ISAMS activities in GEO (and in some cases also in LEO). Stand-alone ISAMS systems will operate in conjunction with onboard ISAAC systems (assessed in an earlier sections). The following table (Table E-9) presents the results of a preliminary assessment of key in-space assembly, maintenance and servicing technology options.

Table E-9 Results of Preliminary SPS ISAAC Technology Assessment

TECHNOLOGY REQUIREMENT		SYSTEM APPLICATION				TRL	R&D3
TECHNOLOGY TOPIC	SUB-TOPIC	Type-I SSP TNV	Type-II SSP TNV	Type-III SSP TNV	Other SSP TNV / Type		
Assembly Robotics	In-Space Factory Assembly Robotics	3-4	1	1	CD	3-4	2-3
	Large-Scale Space Crane(s)	4-5	1-2	1-2	CD	4-5	1-2
	Auto. Rendezvous & Docking	2-3	4-5	4-5	CD	4-5+	1-2

TECHNOLOGY REQUIREMENT		SYSTEM APPLICATION				TRL	R&D3
TECHNOLOGY TOPIC	SUB-TOPIC	Type-I SSP TNV	Type-II SSP TNV	Type-III SSP TNV	Other SSP TNV / Type		
	Robotics w/ Insect-Class Intelligence	2-3	2-3	4-5	CD	3-4	1-2
	Reconfigurable Modular Robotics	2-3	2-3	4-5	CD	4-5	2-3
Component Interconnects	Mechanical Interconnects	4-5	4-5	4-5	CD	4-5	1-2
	Space Welding and Bonding	2-3	1-2	1	CD	3-4	2-3
	Actively controlled Interconnects	2-3	4-5	4-5	CD	2-3	2-3
	PMAD Electrical Interconnects	2-3	4-5	4-5	CD	2-3	2-3
	TMS / Thermal Interconnects	4-5	2-3	1-2	CD	2-3	2-3
	CMD / Comm Wiring / Harness	2-3	4-5	4-5	CD	3-4	2-3
	CMD / Comm Wireless Connects	2-3	4-5	4-5	CD	2-3	1-2
Space Structures	See SPS Generic Platform Technologies						

E.2.4.4 Ground Energy and Interface Systems TRRA Results. There are several key technologies needed for the ground energy and interfaces systems, some of which are based on the primary WPT system options; these include (1) RF conversion via a rectenna, including both panel and mesh type rectennas; (2) band-gap tailored PV (for laser transmission); and, (3) direct radiant energy based thermo-chemical conversion systems. Other potentially important component technologies include, high efficiency grid integration transformers, rolling energy storage systems, etc. The following table (Table E-10) presents the results of a preliminary assessment of key technology options related to ground energy and interface systems.

Table E-10 Results of Preliminary SPS GEIS Technology Assessment

TECHNOLOGY REQUIREMENT		SYSTEM APPLICATION				TRL	R&D3
TECHNOLOGY TOPIC	SUB-TOPIC	Type-I SSP TNV	Type-II SSP TNV	Type-III SSP TNV	Other SSP TNV / Type		
WPT Ground Receiver - Power	Microwave Rectenna - Panel	4-5	1	4-5	CD	6	1
	Microwave Rectenna - Mesh	4-5	1	4-5	CD	4-5	1-2
	Tailored Bandgap PV Array	1	5	1	CD	6+	1
WPT Ground Rcvr – Thermal Energy	Radiant Energy / Thermo-Chemical	3-4	3-4	3-4	3-4	2-3	2-3
Power Grid Integration	Power Mgt / Transformers	1-2	1-2	1-2	1-2	5-6	5-6
	Rolling Power Storage	3-4	3-4	3-4	3-4	2-3	2-3

E.2.4.5 In-Space Resources and Manufacturing TRRA Results. The future use of in-space resources and in-space manufacturing of SPS systems and/or consumables represents an especially promising option for dramatically reductions in the life cycle costs of solar power satellites in the longer term. However, these capabilities will require the development, maturation and deployment of a range of specific new technologies before becoming feasible (much less economically advantageous). This technology assessment comprises only a few of the specific R&D areas that will be needed to realize in-space resources and manufacturing (ISRM) for SPS. These capabilities include: (1) Materials acquisition; (2) in-situ materials processing; (3) product manufacturing and packaging; and, (4) low-cost product transportation to SPS for utilization. The following table (Table E-11) presents the results of a preliminary assessment of key technology options related to in-space resources and manufacturing.

Table E-11 Results of Preliminary SPS ISRM Technology Assessment

TECHNOLOGY REQUIREMENT		SYSTEM APPLICATION				TRL	R&D3
TECHNOLOGY TOPIC	SUB-TOPIC	Type-I SSP TNV	Type-II SSP TNV	Type-III SSP TNV	Other SSP TNV / Type		
Materials Acquisition	Excavation and Beneficiation	2-3	2-3	2-3	2-3	3-4	1-2
	Preprocessing and Separation	2-3	2-3	2-3	2-3	3-4	1-2
In-Situ Materials Processing	Thermochemical processing	2-3	1-2	2-3	2-3	3-4	2-3
	Electrochemical Processing	2-3	1-2	2-3	2-3	3-4	2-3
	Mechanical Processing	2-3	1-2	2-3	2-3	4-5	1-2
Product Mfg and Packaging	Rapid Prototyping Type Manufactur'g	2-3	1-2	2-3	2-3	3-4	1-2
	Smelting and Forging	2-3	1-2	2-3	2-3	2-3	2-3
	Liquefaction and Storage	2-3	2-3	2-3	2-3	3-4	1-2
	Factory Assembly Type Mfg.	2-3	1-2	2-3	2-3	2-3	2-3
Low-Cost Transportation	Chemical Prop. Transportation	1-2	1-2	1-2	1-2	5-6	1
	MagLev Launch Systems	2-3	2-3	2-3	2-3	3-4	1-2

APPENDIX F

SYSTEMS ANALYSIS METHODOLOGY

The IAA space solar power study systems analysis methodology was constrained to high-level considerations by the limited scope of the overall effort. Figure F-1 presents the overall systems analysis methodology used. Following the identification of goals and boundary conditions for the systems analysis process, the methodology began with the physic-based identification of key systems and technology issues for SSP; see Step 1 in Figure F-1. This includes questions concerning wireless power transmission, space transportation, and others.

Figure F-1 Systems Analysis Methodology Overview

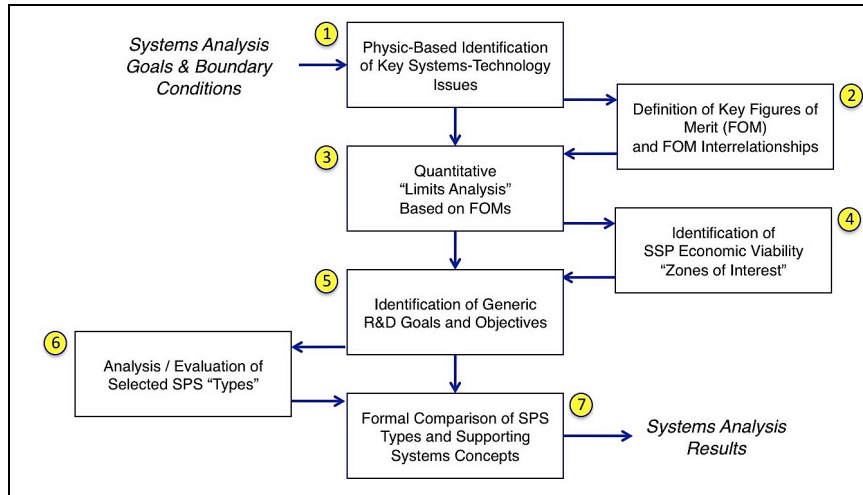

Credit: Figure Provided by Artemis Innovation Management Solutions LLC

As result of the first step in the methodology (Step “1” in the figure), SSP figures of merit (FOMs) and the principal interrelationships among them were defined; see Step 2 in the figure. Based on these FOMs, a high-level, but quantitative “limits analysis” was conducted (Step “3” in the figure), and the results used to identify SSP economic viability “zones of interest” (Step 4 in the figure). (Details of the “limits analysis” approach are described in the body of the report.)

The next stage was the identification of generic research and development goals and objectives for space solar power systems (see Step 5). These goals/objectives, in the context of the “zones of interest”, were then used to analyze and evaluate the three types of SPS that were selected for consideration by the IAA study (see Step 6). Finally, the several promising types of SPS were formally compared, along with both concept specific and generic SPS-supporting systems concepts (see Step 7), based on the FOMs, the R&D goals and objectives, and the particulars of the concepts.

APPENDIX G

A SELECTION OF PAST WPT TESTS (GROUND AND FLIGHT)^{lv, lvi}

YEAR	TEST	DESCRIPTION	KEY ACCOMPLISHMENT(S)
1964	Beamed Power Helicopter	Raytheon / William Brown demonstrated microwave power transmission to a rectenna driving an electric motor / helicopter, and resulting powered flight	Established feasibility of WPT in the field; possibility of wireless powered flight.
1975	High Power WPT	NASA JPL / Richard Dickinson, and Raytheon / W. Brown demonstrated high power (c. 34 kW) microwave power transmission using a station of the Deep Space Network as the transmitter.	Highest power WPT demonstration accomplished to date.
1983	MINIX - High Power WPT through Ionosphere	Kyoto University performed the first-ever magnetron phased array test from a mother section to a daughter section of a sounding rocket through the ionosphere (microwave ionosphere nonlinear interaction experiment – MINIX).	First test of microwave WPT thru' ionosphere.
1987	SHARP – Microwave Powered Aircraft	Canadian demonstration of the Stationary High Altitude Relay Platform (SHARP) concept, using microwave wireless power transmission.	First demonstration of a microwave WPT powered, unpiloted aircraft
1992	METS – Non-Linear Ionosphere Interactions	METS (Microwave Energy Transmission in Space) experiment, which in 1992 used a sounding rocket to investigate the nonlinear effects of a WPT beam in the space plasma environment.	First measurement of non-linear ionosphere interactions due to microwave WPT.
1995	Power Transmission to Airship	Kobe University demonstrated microwave power transmission from a dish/magnetron to an airship/rectenna during the WPT 1995 Conference. (The rectenna output was roughly 3 kW.)	Test of 5 kW-class microwave WPT to an airship.

YEAR	TEST	DESCRIPTION	KEY ACCOMPLISHMENT(S)
2003	Integrated Sandwich Module Demo	Kobe University developed an integrated working model of a microwave sandwich SPS module for demonstration at the World Space Congress in Houston, Texas.	Established a physical baseline for a sandwich module at 2.45 GHz, including PV, structure, RF elements.
2006	Furoshiki Sounding Rocket Experiment	University of Tokyo, Kobe University and University of Vienna conducted together a sounding rocket based test of a large deployable mesh, mother & daughter satellites, retrodirective phased array (satellite to ground) and crawling robots. ^{ivii}	Accomplished the first-ever test in the space environment of an end-to-end SPS deployment concept (including RF elements) – albeit at very low TRL.
2008	Solar-Powered Microwave WPT at Long Range	With sponsorship from Discovery Communications, an international team (described earlier) demonstrated solar-powered microwave power transmission over a distances of 148 km.	First solar-powered long-range demo of WPT @ 2.45 GHz between Haleakala and Mauna Loa (148 km).
2009	Advanced Technology Retrodirective Phased Array Test	During the September 2009 International Symposium on Space Solar Power (SPS 2009) in Toronto, Canada, Kobe University demonstrated a next generation / advanced technology system (including power transmission to a small moving vehicle).	Testing of microwave WPT with high-efficiency solid-state amplifiers, with active beam steering to a moving vehicle.

APPENDIX H

COMPARISON OF DEMAND LOAD VS GROUND RENEWABLE ENERGY^{lviii}

The following appendix presents a high-level, largely graphical comparison of the regular daily variation in power demand, as compared to the highly intermittent (and often seasonally varying) power delivered by ground based solar and wind power systems.

H.1 Demand for Electrical Power (c. 2010)

Figure H-1 illustrates the likely variability in electrical power demand over a twenty-four hour period. (This figure does not reflect a specific locality, but follows the general demand curve that might be expected in the middle state of the US in summer.) The figure illustrates (a) the baseload power level below which demand does not drop during a 24-hour period, and (b) the variable load power level, which is shown to peak in the later part of the afternoon during a typical summer day.

Figure H-1 Typical Power Demand 24-Hour Variability

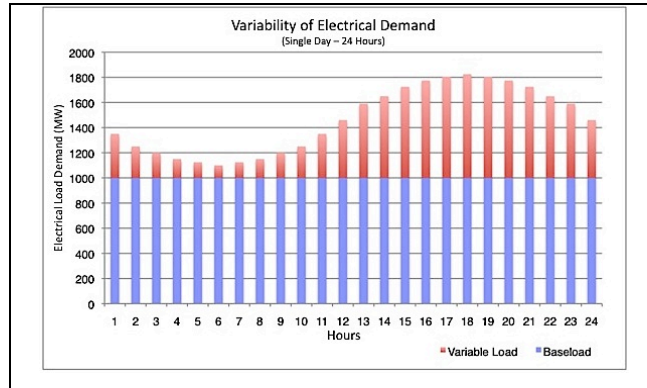

H.2 Solar Power Capacity

Figure H-2 illustrates the solar power generation capacity that might be available from a PV array over several twenty-four hour periods with changing weather patterns during the period. (Again, this figure does not

reflect a specific locality or a specific multi-day period.) The figure illustrates the general trend that a ground-based PV solar power system delivers power during daylight hours, and is highly dependent on the clarity of the air and on the overall weather during the day. (Actual data would certainly not produce smooth curves like these from real days/locations.)

Figure H-2 Notional Solar Power Capacity Over Several Days

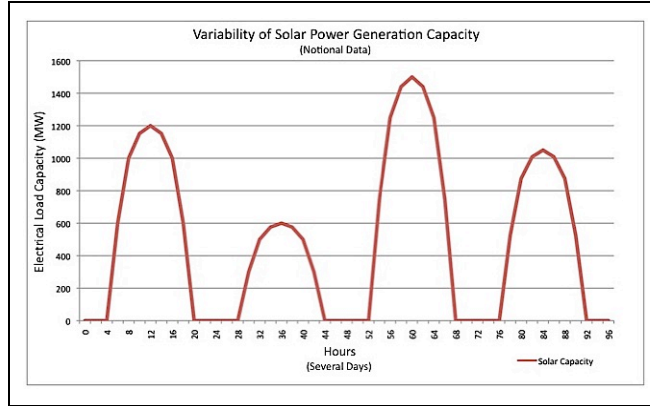

In Figure H-2, the maximum possible power output from the solar array is 1,500 MW; this is the overall capacity of the system.

H.3 Wind Power Capacity

Figure H-3 illustrates the wind power generation capacity that might be available from a wind turbine farm over several twenty-four hour periods with changing weather patterns and wind conditions both on a hourly basis, and during the period. (Once again, this figure does not reflect a specific locality or a specific multi-day period.) The figure illustrates the fact that a wind farm delivers power based on the available wind conditions, and is highly dependent the overall weather during any given day and/or season. In Figure H-3, the maximum possible power output from the wind farm is 1,500 MW; as in the case of the solar array, this is the overall capacity of the system.

H.4 Integrated Solar and Wind Power Capacity

Figure H-4 illustrates the wind power generation capacity that might be available from an integrated solar PV array system, and a wind turbine farm

over several twenty-four hour periods with changing weather patterns and wind conditions both on a hourly basis, and during the period. In Figure H-4, the maximum possible power output from combined solar array and wind farm is 3,000 MW; however, although this is the overall capacity of the system, it is not usually reached because the intensity of the sunlight and the wind velocity peak at different times during the day.

Figure H-3 Notional Wind Power Generation Capacity Over Several Days

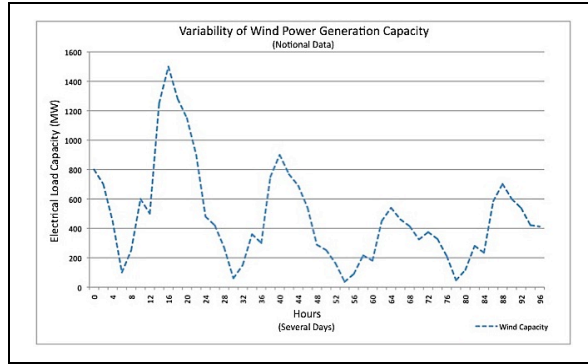

H.5 Comparison of Power Demand and Solar / Wind Power Generation Capacity

Figure H-5 illustrates the likely mismatch between the regular daily demand for electrical power, and the available solar power and wind power generation capacity that might be available from an integrated solar PV array system and a wind turbine farm over several twenty-four hour periods. Even in the case in which the total capacity of the solar and wind power systems are 3,000 MW, these systems are unable to satisfy the power demand (which never exceeds 1,800 MW).

This figure illustrates the systemic challenge for most renewable energy sources to meet the demands of industrial societies. Current solutions involve limiting the amount of intermittent renewable power in the local grid, and using hydroelectric power, nuclear power or (most typically) fossil fuel power plants to assure demand is met. In a future scenario involving stand-alone renewable energy sources, only large-scale energy storage systems will be capable of satisfy power demand requirements.

This is an example of a scenario in which space solar power (particularly if that power can be re-directed from one target market to

another during a 24 hour period) might be effectively integrated with ground based intermittent renewable energy sources.

Figure H-4 Notional Solar and Wind Power Generation Capacity Over Several Days (Integrated)

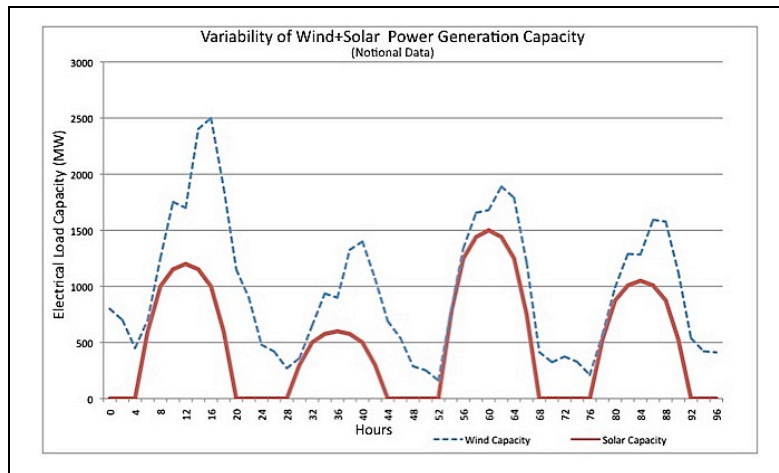
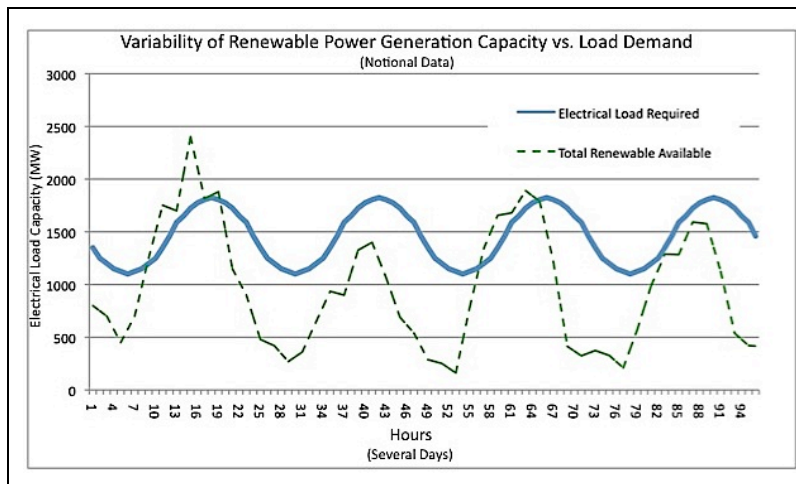

Figure H-5 Integrated Comparison of Electrical Power Demand vs. Notional Solar / Wind Power Generation Capacity



APPENDIX I

REFERENCES

-
- i Hoffert, Martin, Ph.D. et al.; “Advanced Technology Paths to Global Climate Stability: Energy for a Greenhouse Planet” (*Science* 298, 981). 2002.
 - ii Hoffert, Martin, Ph.D. et al; 2002.
 - iii Strickland, John K.; “Base Load Power From Earth and Space,” (Presented at the International Symposium on Solar Energy from Space / IAA “SPS 2009” Workshop; Toronto, Canada). 8-11 September 2009.
 - iv References include:
<http://geography.about.com/od/obtainpopulationdata/a/worldpopulation.htm>, <http://www.iiasa.ac.at/Research/POP/proj07/>, <http://www.prb.org/Publications/PopulationBulletins/2001/WorldPopulationFuturesPDF338KB.aspx>, and others
 - v References include:
<http://www.bp.com/sectiongenericarticle.do?categoryId=9035979&contentId=7066648>, <http://www.eia.doe.gov/oiaf/ieo/>, US DOE International Energy Outlook (DOE/EIA-0484) 2010, http://www.worldenergy.org/publications/survey_of_energy_resources_2007/solar/719.asp, <http://www.iea.org/>, <http://www.worldenergyoutlook.org/>
 - vi References include: http://rainforests.mongabay.com/09-carbon_emissions.htm,
 - vii References include: <http://www.eia.doe.gov/oiaf/ieo/highlights.html>, <http://www.eia.doe.gov/oiaf/ieo/>, <http://www.worldenergyoutlook.org/>
 - viii References include: http://rainforests.mongabay.com/09-carbon_emissions.htm, <http://co2now.org/>, <http://www.ipcc.ch/ipccreports/sres/emission/index.php?idp=116>,
 - ix Reference: http://en.wikipedia.org/wiki/Hubbert_peak_theory

-
- x Tadeusz W. Patzek and Gregory D. Croft, “A global coal production forecast with multi-Hubbert cycle analysis” (*Energy* 35; pp 3109-3122). 2010.
- xi Glaser, Peter, Ph.D.; “Method and Apparatus for Converting Solar Radiation to Electrical Power.” (US Patent No. 3,781,647; U.S. Patent and Trademark Office; Washington, D.C.) 25 December 1973.
- xii Feingold, Harvey, et al, “Space Solar Power — A Fresh Look at the Feasibility of Generating Solar Power in Space for Use on Earth” (SAIC; Schaumberg, Illinois, USA). 02 April 1997.
- xiii Mankins, John C. and Howell, Joseph T.; “Overview of the Space Solar Power Exploratory Research and Technology Program -- AIAA 2000-3060 (35th Intersociety Energy Conversion Engineering Conference; Las Vegas, Nevada USA). 24-28 July 2000.
- xiv National Research Council, Aeronautics and Space Engineering Board, Committee for the Assessment of NASA's Space Solar Power Investment Strategy, Aeronautics and Space Engineering Board, “Laying the Foundation for Space Solar Power: An Assessment of NASA's Space Solar Power Investment Strategy.” (National Academies Press; Washington, D.C. USA). 2001.
- xv Mankins, John C. and Kaya, Nobuyuki, “A Report On The Status of the IAA Study Group on Solar Energy from Space,” IAC-C3.1.1 (Presented at the 60th International Astronautical Congress; Daejeon, Republic of Korea). October 2009.
- xvi Mankins, John C., “Space Solar Power: A Fresh Look,” AIAA 95-3653 (Presented at the 1995 AIAA Space Programs and Technologies Conference, Huntsville, Alabama). September 1995.
- xvii Feingold, Harvey, et al, “Space Solar Power — A Fresh Look at the Feasibility of Generating Solar Power in Space for Use on Earth” (SAIC; Schaumberg, Illinois, USA). 02 April 1997.
- xviii Mankins, John C., “A Technical Overview Of The ‘SunTower’ Solar Power Satellite Concept” (IAF-97-R.2.08; 38th International Astronautical Federation, Turin, Italy) 6-10 October 1997.
- xix National Research Council, Aeronautics and Space Engineering Board, Committee for the Assessment of NASA's Space Solar Power Investment Strategy, Aeronautics and Space Engineering Board, “Laying the Foundation for Space Solar Power: An Assessment of

-
- NASA's Space Solar Power Investment Strategy.” (National Academies Press; Washington, D.C. USA). 2001.
- xx Criswell, David R., “Power Collection and Transmission System and Method” (US Patent No. 3,781,647; U.S. Patent and Trademark Office; Washington, D.C.) 28 May 1991.
- xxi Office of Technology Assessment, US Congress; “Solar Power Satellites”. (Washington DC.) 1981.
- xxii Howell, Joseph T. and Mankins, John C., “Highly Reusable Space Transportation – A Summary Report; Retrospective 2009” (Presented at the International Symposium on Solar Energy from Space / IAA “SPS 2009” Workshop; Toronto, Canada). 8-11 September 2009.
- xxiii “Space-Based Solar Power As an Opportunity for Strategic Security – Phase 0 Architecture Feasibility Study”. (A Report to the Director, DOD National Security Space Office) 10 October 2007.
- xxiv Howell, Joseph T. and Mankins, John C., “Highly Reusable Space Transportation – A Summary Report; Retrospective 2009” (Presented at the International Symposium on Solar Energy from Space / IAA “SPS 2009” Workshop; Toronto, Canada). 8-11 September 2009.
- xxv Powell, James, R., Maise, George and Rather, John, “Maglev Launch – An Ultra Low Cost Way to Deploy Space Solar Power Systems” (Presented at the International Symposium on Solar Energy from Space / IAA “SPS 2009” Workshop; Toronto, Canada). 8-11 September 2009.
- xxvi Commercial Space Transportation Study Team, “Commercial Space Transport Study Final Report,” (Distributed by W. Piland, NASA Langley Research Center; Hampton, Virginia; USA). April 1994.
- xxvii Powell, James et al.; “Development of Large Structures in Space Using the Magnetically Inflated Cable (MIC) System”; (57th International Astronautical Congress; Valencia, Spain). October 2-5, 2006.
- xxviii Mankins, John C.; “An Affordable Lunar Launch Concept: MagLifter on the Moon (revisiting the Lunatron)”; (International Symposium on Solar Energy from Space / SPS 2009 at the Ontario Science Center; Toronto, Canada). 8-10 September 2009.
- xxix Ignatiev, Alex, Ph.D., “Opportunities to Employ Lunar Surface Materials in a Future Space Solar Power Economy,” (Presented at the

-
- International Symposium on Solar Energy from Space / IAA “SPS 2009” Workshop; Toronto, Canada). 8-11 September 2009.
- xxx Mankins, John C.; “An Affordable Lunar Launch Concept: MagLifter on the Moon (revisiting the Lunatron)”; (International Symposium on Solar Energy from Space / SPS 2009 at the Ontario Science Center; Toronto, Canada). 8-10 September 2009.
- xxxii Mankins, John C.; “Technology Readiness Levels – Definitions” (White Paper – NASA Headquarters; Washington, D.C.; USA). 1995.
- xxxiii Howell, Joseph T. and Mankins, John C., “Highly Reusable Space Transportation – A Summary Report; Retrospective 2009” (Presented at the International Symposium on Solar Energy from Space / IAA “SPS 2009” Workshop; Toronto, Canada). 8-11 September 2009.
- xxxiiii Prof. Ram Jakhu, “Solar Energy from Space – Space Law and Possibilities for an International Space Treaty” (International Symposium on Solar Energy from Space; Ontario Science Centre, Toronto, Canada). 8-10 September 2009.
- xxxiv Lark, Eva-Jane, “Policy And Financial Considerations and Prospects for Space Solar Power” (International Symposium on Solar Energy from Space; Ontario Science Centre, Toronto, Canada). 8-10 September 2009.
- xxxv “Treaty On Principles Governing The Activities Of States In The Exploration And Use Of Outer Space, Including The Moon And Other Celestial Bodies” (Signed at Washington, London, Moscow). 27 January 1967.
- xxxvi Pearce, J. and Lau A., “Net Energy Analysis for Sustainable Energy Production from Silicon Based Solar Cells,” (Proceedings of Solar 2002 Sunrise on the Reliable Energy Economy, Reno, Nevada). June 15-20, 2002.
- xxxvii Pearce, J. and Lau A., “Net Energy Analysis for Sustainable Energy Production from Silicon Based Solar Cells,” (Proceedings of Solar 2002 Sunrise on the Reliable Energy Economy, Reno, Nevada). June 15-20, 2002.
- xxxviii Franco Ongaro, Leopold Summerer; “Peter Glaser Lecture: Space And A Sustainable 21st Century Energy System”; (57th International Astronautical Congress, Paper IAC-06-C3.1.01). 2006.

-
- xxxix Personal communication with Robert Wegeng regarding the approach to the thermal analysis described in this report. 19 February 2010.
- xl Brandhorst, Henry; “Megawatt SEPS and Mars Exploration”; (International Symposium on Solar Energy from Space / SPS 2009 at the Ontario Science Center; Toronto, Canada). 8-10 September 2009.
- xli Brandhorst, Henry; “Megawatt SEPS and Mars Exploration”; (International Symposium on Solar Energy from Space / SPS 2009 at the Ontario Science Center; Toronto, Canada). 8-10 September 2009.
- xlii Mihara, Shoichiro; Fuse, Yoshiharu; Saito, Takashi, and Ijichi, Koichi; “WPT Technology Demonstration Options at USEF”; (International Symposium on Solar Energy from Space / SPS 2009 at the Ontario Science Center; Toronto, Canada). 8-10 September 2009.
- xliii See: http://en.wikipedia.org/wiki/Diffraction#Diffraction-limited_imaging for a useful article on the topic of diffraction and diffraction limited optics.
- xliv McSpadden, James; “Advances in RF Wireless Power Transmission”; (International Symposium on Solar Energy from Space / SPS 2009 at the Ontario Science Center; Toronto, Canada). 8-10 September 2009.
- xlv Various on-line and document references; including a Wikipedia web reference: http://en.wikipedia.org/wiki/Laser_safety, an OSHA reference at: <http://www.eyesafety.4ursafety.com/OSHA-Laser-regulations.html>, and others.
- xlvi Web reference: <http://www.grc.nasa.gov/WWW/SiC/>
- xlvii Wikipedia web reference: http://en.wikipedia.org/wiki/Delta-y_budget
- xlviii Strickland, John K.; “Base Load Power From Earth and Space,” (Presented at the International Symposium on Solar Energy from Space / IAA “SPS 2009” Workshop; Toronto, Canada). 8-11 September 2009.
- xlx Lark, Eva-Jane, “Policy And Financial Considerations and Prospects for Space Solar Power” (International Symposium on Solar Energy from Space; Ontario Science Centre, Toronto, Canada). 8-10 September 2009.
- ¹ Kaya, Nobuyuki; Mankins, John C.; Iwashita, Masashi; Little, Frank; and Marzwell, Neville; “Hawaii Demonstration of Microwave Beam

-
- Control, supported by the Discovery Channel”; (International Symposium on Solar Energy from Space / SPS 2009 at the Ontario Science Center; Toronto, Canada). 8-10 September 2009.
- ii Penn, Jay, and Law, Glenn, “Future SSP Systems Concepts: the Laser Option – Commercial and Military Applications,” (Presented at the International Symposium on Solar Energy from Space / IAA “SPS 2009” Workshop; Toronto, Canada). 8-11 September 2009.
- lii Mankins, John C.; “Technology Readiness Levels – Definitions” (White Paper – NASA Headquarters; Washington, D.C.; USA). 1995.
- liii Mankins, John C.; “Research & Development Degree of Difficulty – A White Paper” (White Paper, Advanced Projects Office, NASA Headquarters; Washington, D.C.; USA). 10 March 1998.
- liv Howell, Joseph T. and Mankins, John C., “Highly Reusable Space Transportation – A Summary Report; Retrospective 2009” (Presented at the International Symposium on Solar Energy from Space / IAA “SPS 2009” Workshop; Toronto, Canada). 8-11 September 2009.
- lv McSpadden, James; “Advances in RF Wireless Power Transmission”; (International Symposium on Solar Energy from Space / SPS 2009 at the Ontario Science Center; Toronto, Canada). 8-10 September 2009.
- lvi Hashimoto, Kozo; “Microwave Power Transmission Activities in the world”, (Report to URSI). c. 2005.
- lvii Kaya, Nobuyuki, et al.; “Crawling Robots On Large Web In Rocket Experiment On Furoshiki Deployment” (55th International Astronautical Congress; Vancouver, Canada). 2004.
- lviii Strickland, John K.; “Base Load Power From Earth and Space,” (Presented at the International Symposium on Solar Energy from Space / IAA “SPS 2009” Workshop; Toronto, Canada). 8-11 September 2009.