

New Concepts and Technologies from NASA's Space Solar Power Exploratory Research and Technology Program

John C. Mankins
Advanced Projects Office
Office of Space Flight
NASA Headquarters
Washington, DC USA

Joe T. Howell
Advanced Projects Office
Flight Projects Directorate
Marshall Space Flight Center
Huntsville, Alabama USA

Daniel A. O'Neil
Advanced Projects Office
Flight Projects Directorate
Marshall Space Flight Center
Huntsville, Alabama USA

Abstract

Space Solar Power (SSP) systems are an integral infrastructure element within Gerard K. O'Neill's vision for the human colonization of space. Since 1995, NASA has conducted conceptual design and analysis of SSP systems and technologies. The most recent study, the SSP Exploratory Research and Technology (SERT) activity, involved an agency wide team with participation from the aerospace industry, the energy sector, other government agencies, universities, and non-profit organizations. Products from the SERT activity include an investment portfolio of SSP technologies, technology development roadmaps, conceptual designs and analysis, technology prototypes, and ground demonstrations. This paper presents some of the technology prototypes and discusses how SSP will enable space manufacturing.

Introduction

Recent Space Solar Power (SSP) studies conducted by the National Aeronautics and Space Administration (NASA) included:

- Fresh Look study from 1995 to 1997
- Concept Definition Study in 1998
- SSP Exploratory Research and Technology (SERT) study from 1999 through 2000.

Approximately thirty concepts were analyzed during the Fresh Look study. The most promising concept of the group appeared to be the Sun Tower, a fifteen-kilometer gravity gradient configuration using inflatable Fresnel lens concentrators. Variations of the Sun Tower and other concepts were analyzed in the CDS and the SSP management team adopted several ongoing technology development projects across the agency. In 1999, the SERT activity initiated a focused technology research and development program, conducted systems analysis and integration, and developed system demonstrations. This

paper describes some of the system concepts, technology prototypes, and a summary roadmap for SSP. Additionally, this paper discusses the potential applications of SSP concepts and technologies to Space Manufacturing.

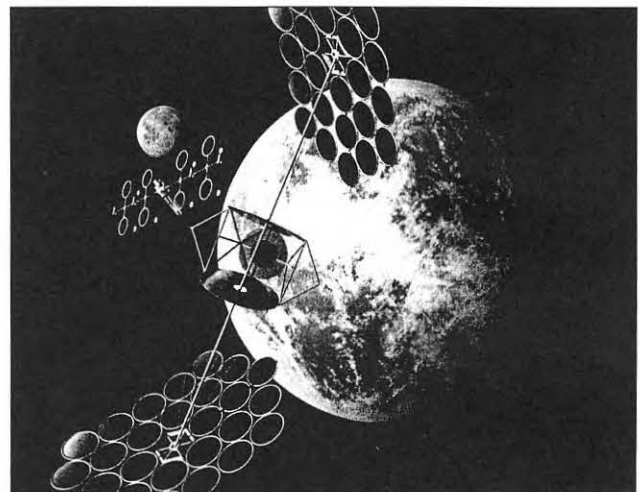

Figure 1 Integrated Symmetrical Concentrator and Solar Clipper

Figure 1 depicts two examples two SSP system concepts, the Integrated Symmetrical Concentrator (ISC) and the Solar Clipper.

The ISC concept is a 1.2 GW system providing power for terrestrial power grids and a variety of space facilities. The Solar Clipper concept is a Solar Electric Propulsion (SEP) based Mars Transfer Vehicle (MTV) that derives from the Sun Tower. Once in orbit around Mars, the Solar Clipper would transmit power to a human colony on the planet's surface.

Approach

Over an 18-month period, a broadly based, well-balanced team conducted system studies and analysis, research and technology development, and ground demonstrations. Elements of the program level Work Break Down (WBS) included:

- A.0 Space Solar Power
- B.1 Solar Power Generation (SPG)
- B.2 Wireless Power Transmission (WPT)
- B.3 Power Management and Distribution (PMAD)
- B.4 Structures, Materials & Controls
- B.5 Thermal Materials and Management
- B.6 Robotics Assembly, Maintenance and Servicing
- B.7 Platform Systems
- B.8 Ground Power Systems
- B.9 Earth-to-Orbit Transportation and Infrastructure
- B.10 In-Space Transportation and Infrastructure
- B.11 Environmental and Safety Factors
- B.12 System Integration (Analysis, Engineering, Modeling)
- B.13 Applications Studies (Science/Exploration/Commercial)
- B.14 Independent Economic and Market Analysis Studies

The following sections will discuss the approach to system analysis, identify the technologies required by all SSP concepts, and describe technology prototypes for elements B.1 through B.6.

Systems Integration, Analysis and Modeling

Technology development programs need system concepts so an engineering team can analyze the interactions of various technologies. However, if an entire program depends on a single point design then any flaws in the point design can jeopardize the whole program. To avoid the Achilles heel of a point design, the SERT activity analyzed a variety of concepts to determine system requirements. System concepts were organized into Model System Categories (MSC) that ranged in power from 100 kilowatts to over 1 gigawatt. These categories enabled the systems to develop a top-level technology roadmap without a single point design. Table 1 provides a brief description of the category, power level, and purpose.

Table 1 Model System Categories

Category	Power	Mission or Objective
MSC 1	~ 100 kW	Free-flyer; WPT, SPG and SEPS; demo-scale;
MSC 2	~ 100 kW	Commercial space option
MSC 3	~ 10 MW	Planetary Surface System; demo-scale; space exploration option
MSC 4	~ 1 GW	Free-flyer; WPT, SPG and PMAD, SEPS; Large demo – Free-flyer; Full-scale solar power satellite; commercial space option
MSC 5	~ 10-100 GW	Operational Interstellar Power Station
MSC 6	~ TBD	"Other Concepts"

MSC 1, 3, and 4 were examined in more detail by most of the SERT team with specific point of departure system concepts. Application and demonstration teams examined MSC 2 and MSC 5 concepts on a case-by-case basis. Various sub-teams examined other concepts that fell into MSC 6 on a case-by-case basis. Each MSC involved one or more Points of Departure (POD). Missions associated with a POD ranged from proving technologies to operational power stations.

When describing the maturity of a technology, NASA uses a scale of Technology Readiness Levels (TRL). The TRL scale ranges from one to nine. A TRL one means that basic principles have been observed and reported. At TRL four, components or breadboards have been demonstrated in a laboratory environment. Achieving a TRL seven involves demonstrating a system prototype in a space environment. A TRL nine means that the technology is ready for an operational flight system.

Conceptual designs within MSC 1 have a power level of approximately 100 kilowatts. A prototype version of the Sun Tower and Solar Clipper concepts served as POD 1.1

for MSC 1. Figure 2 depicts a mission for a near term flight demonstration of Radio Frequency (RF) and optical power transmission. Objectives of the mission include proving that the subsystem and component technologies have reached a TRL 7.

Notes 6a and 6b within Figure 2 identify a Crystal-growth free-flying furnace as an example of a micro-gravity application. Even in near-term technology demonstrations such as POD 1.1, an SSP technology development program can provide opportunities for demonstrating the feasibility Space Manufacturing technologies.

SERT Systems Integration, Analysis, and Modeling MSC 1 Advanced System Concept (POD 1.1)

Near-Term Technology Demonstration with RF and Optical Power Transmission

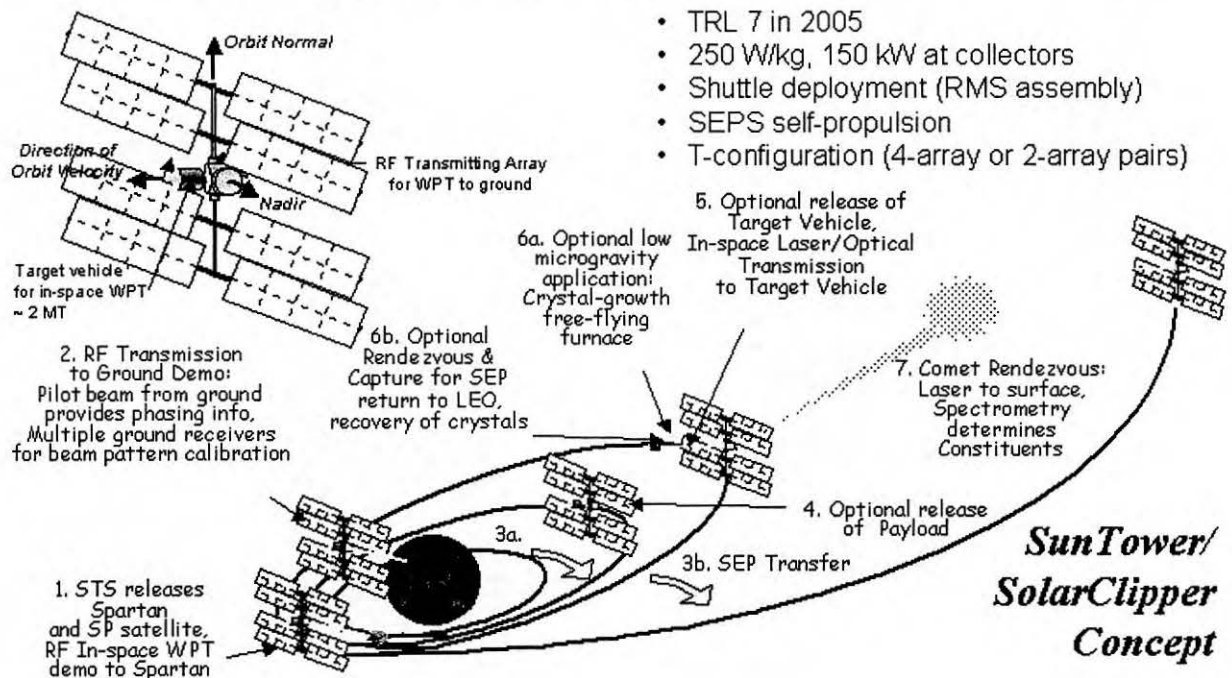

- TRL 7 in 2005
- 250 W/kg, 150 kW at collectors
- Shuttle deployment (RMS assembly)
- SEPS self-propulsion
- T-configuration (4-array or 2-array pairs)

Figure 2 Point of Departure 1 for Model System Category 1

Conceptual designs within MSC 3 would provide approximately 10 megawatts of power. Figure 3 depicts a flight demonstration with space exploration option. Based on its appearance, this configuration is referred to as the Abacus concept. Objectives of POD 3.1 include demonstrating subsystems and components at a TRL seven and deploying payloads in an orbit around Earth, or the Moon, or Mars.

Note one, in Figure 3 indicates that the system would be deployed and assembled in Low Earth Orbit (LEO). Robotic construction teams could assemble the system, which would prove the feasibility of

automated assembly of future large-scale space facilities.

Notes five and seven describe deployment of payloads or cargo and power beaming to the Moon or Mars. Payloads could include construction or exploration robots. Cargo could include supplies for future human exploration missions.

Note six, in Figure 3, identifies an objective of power beaming to an asteroid surface. Data from this experiment would benefit the design and development of future mass drivers for maneuvering asteroids.

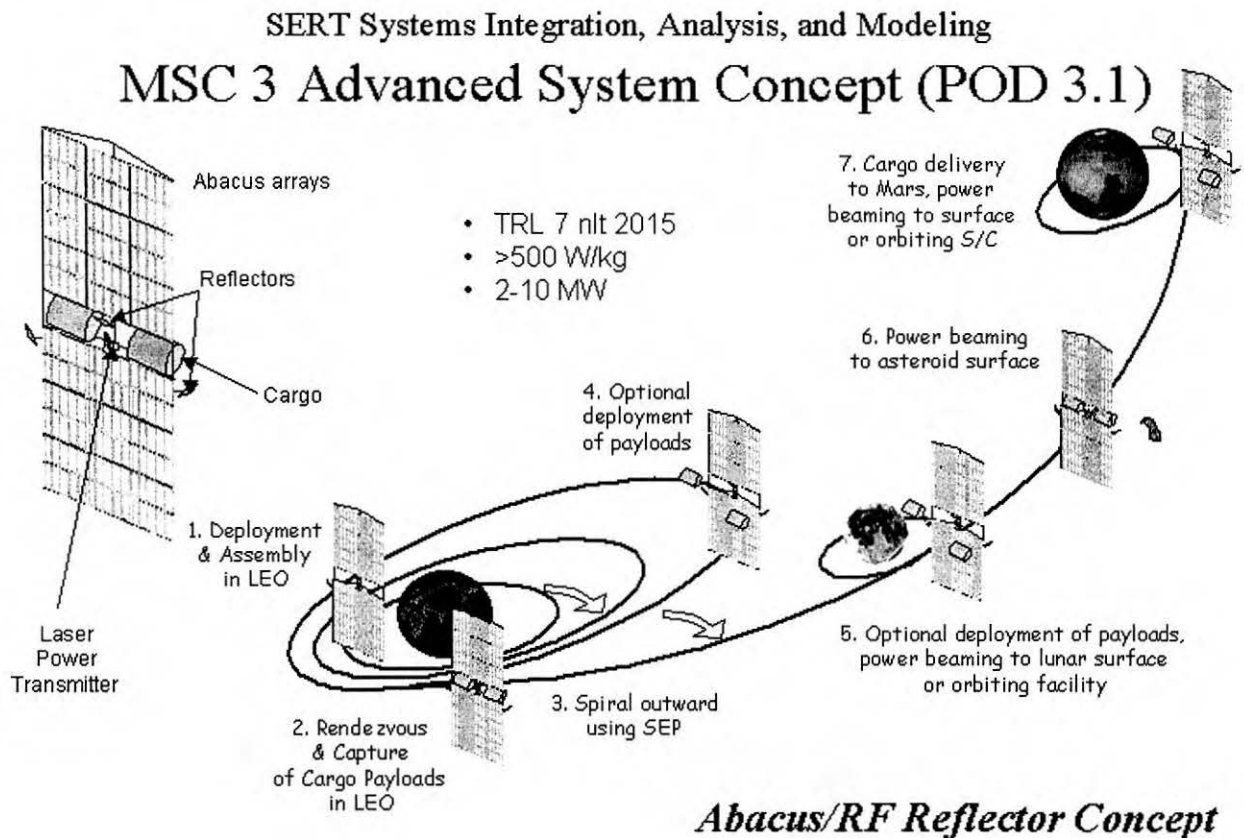

Figure 3 Abacus Concept Supporting an Exploration Mission

Emerging Third-World countries, Human space colonies and large-scale space manufacturing facilities will require tremendous amounts of power. To meet these future power demands, concepts within MSC four provide approximately one gigawatt of power. Concepts within MSC four would be power plants in space. A constellation of full-scale SSP satellites in Geosynchronous Earth Orbit (GEO) would supply customers on Earth and in Space.

Figure 4 depicts an Integrated Symmetrical Concentrator (ISC) concept. This concept was previously depicted in Figure 1.

SERT Systems Integration, Analysis and Modeling
MSC 4 Advanced Systems Concept
(POD 4.3)

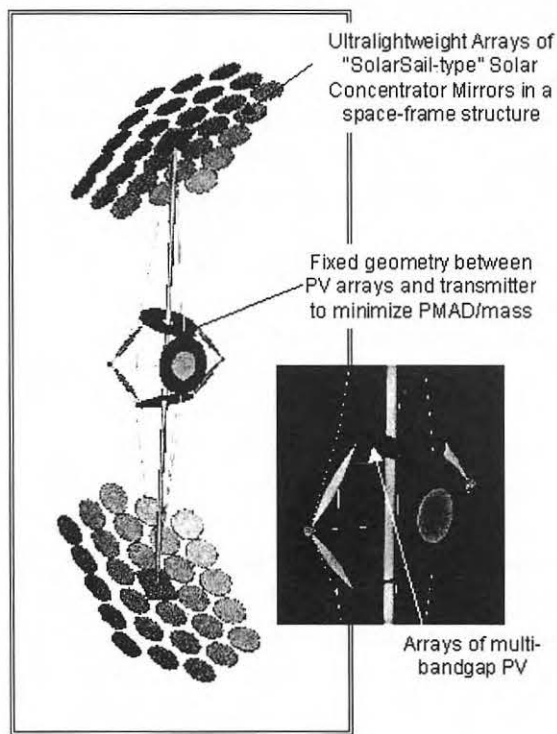

Figure 4 Integrated Symmetrical Concentrator

Technologies used in the ISC include arrays inflatable toroids and thin film mirrors concentrating sunlight onto multi-band gap photovoltaic (PV) arrays. The solar collectors always face the Sun with very little, if any, shadowing. The fixed geometry between the PV arrays and transmitter minimizes the required mass for a Power Management and Distribution (PMAD) subsystem. This configuration allows continuous heat rejection because the backs of the PV arrays face open space. Given that the reflectors and structure could be much lighter than the large PV arrays, this design reduces the rotational mass.

Common Technologies

All of the concepts across the MSCs include subsystems for solar power generation, managing the power, transmitting the power to a destination, and receiving the power. Any spacecraft will also include structure, thermal management system, propulsion, and a control system. To get a system into space, there must be an Earth To Orbit (ETO) transportation system. Commonality among the subsystems and comparing sensitivity analysis among several concepts enabled the System Integration Working Group (SIWG) to develop program level requirements. Goals and requirements for an SSP technology development program include:

- PMAD
 - ✓ Reduced mass for DC-DC converters
 - ✓ High voltage switches and cabling
 - ✓ Lightweight, compact arc suppression for high voltage lines
- Solar Power Generation (PV) -
 - ✓ 1 kg/kW photovoltaic arrays
 - ✓ 40-50 percent efficiency
 - ✓ Arc suppression of high voltage PV arrays (non-LEO applications)
 - ✓ Low Cost arrays, approximately \$1 to \$5 per Watt
- Solar Power Generation Systems -

- ✓ Rigidized inflatable concentrators
- ✓ High temperature receivers with advanced material heat pipes
- ✓ High temperature materials for Brayton engines
- ✓ High temperature inflatable pumped loop radiators
- Wireless Power Transmission (WPT)
 - ✓ Efficient DC-RF devices: 85-90%
 - ✓ Low grating lobes and side lobes
 - ✓ Long lifetime
 - ✓ High temperature operation
- Thermal Management
 - ✓ Higher thermal capacity heat pipes greater than two kilowatts
 - ✓ Lightweight, high temperature radiators
 - ✓ Efficient radiator geometries for high power RF transmitters
- Control and Operation
 - ✓ Design approach for attitude control and station keeping
 - ✓ Electric thruster sizing and placement on structure
 - ✓ Propellant replenishment
 - ✓ Logistics management of expendable systems for in-space transportation
- Propulsion
 - ✓ Modularized Solar Electric Propulsion units with tanks, plumbing, converters and thrusters
- Automated Assembly
 - ✓ Decomposition, modularization and packaging scheme
 - ✓ Assembly approach and sequencing
 - ✓ Robots for assembly and maintenance
 - ✓ Automated docking of packaged units
 - ✓ In-space facility needs for logistics management during assembly and maintenance
- Earth To Orbit (ETO)
 - ✓ Compatibility of payload mass and volume with packing scheme
 - ✓ Launch vehicle turnaround times and fleet size capable of more than one launch per day
- ✓ Launch costs less than or equal to \$400/kg to LEO
- In-Space Transportation
 - ✓ Concepts for Solar Electric Propulsion (SEP) transfer of payloads from LEO to GEO
 - ✓ Concepts for tug or reuse of SEP transportation system for solar power satellite (SPS) control
 - ✓ Low cost propellant with high availability

As stated earlier, an SPS constellation in GEO could provide power human space colonies and large-scale space manufacturing facilities. With the possible exception of solar power generation and WPT, space colonies and space manufacturing facilities will most likely have the same technology requirements identified on the above list.

Enabling Technologies for Different Concepts

Often, system designers face scalability problems with subsystem or component technologies. These problems arise from a paradigm that a full-scale system has to look like the technology demonstration prototype. Strategic planning can mitigate risks associated with scalability through a variety of conceptual designs optimized for specific missions and identifying the enabling relationships between the designs.

Given that technologies can support a variety of concepts, then near term flight demonstrations in MSC 1 and 2 can prove technologies used in systems from MSC 3, 4, and 5, even though the configurations look nothing alike. Figure 5 depicts an example of how the technologies of an MSC 3 concept known as the Abacus enable the development of an MSC 4 concept called the ISC. Technologies for the structure, automated assembly, and control and

operation developed for the Abacus will

enable the development of the ISC.

SERT Systems Integration, Analysis and Modeling

Enabling Technologies for Different Concepts (Examples)

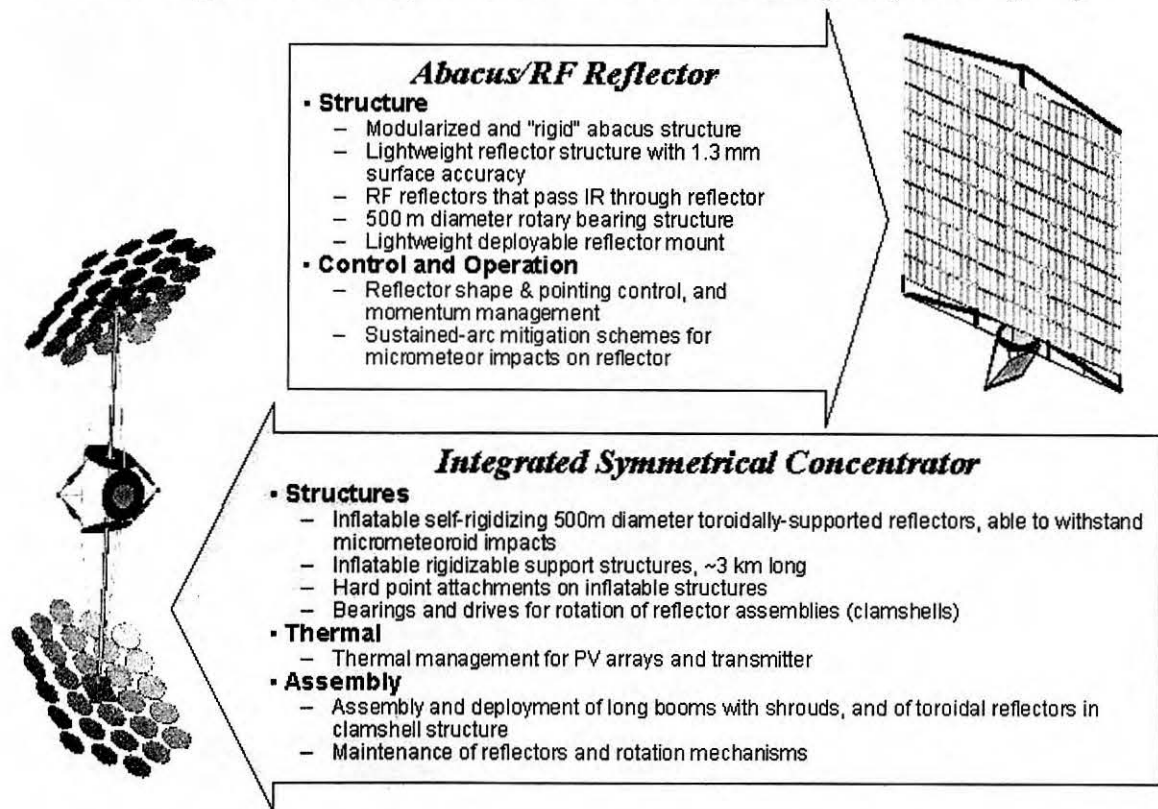

Figure 5 Enabling technologies can be proven on different configurations

Strategic Roadmaps

A primary product of the SSP studies is a robust portfolio of Research and Technology investments. Presentation materials for the technology portfolio include:

- Technology descriptions
- Assessments of a technology's readiness level and the degree of difficulty to advance to the next level
- Conceptual PODs for the MSCs
- Technical reports containing results from system analytical models
- Research and technology (R&T) approaches for WBS elements
- Technology roadmaps for WBS elements

- Hardware prototypes for several of the WBS elements

Figure 6 presents an R&T approach for an SPS (WBS A.0). To meet the system goal of enabling large-scale commercially viable solar power in space for terrestrial and space markets, the SERT team set the architecture cost goal of five cents per kilowatt-hour. This architecture cost goal was allocated across major systems and functions such as power systems, installation, end-to-end-WPT, and operations and maintenance. These cost goals were broken down further into subsystems. The list on the left of Figure 6 identifies competing and complementary technologies that support various system concepts.

Space Solar Power Strategic Research & Technology Approach

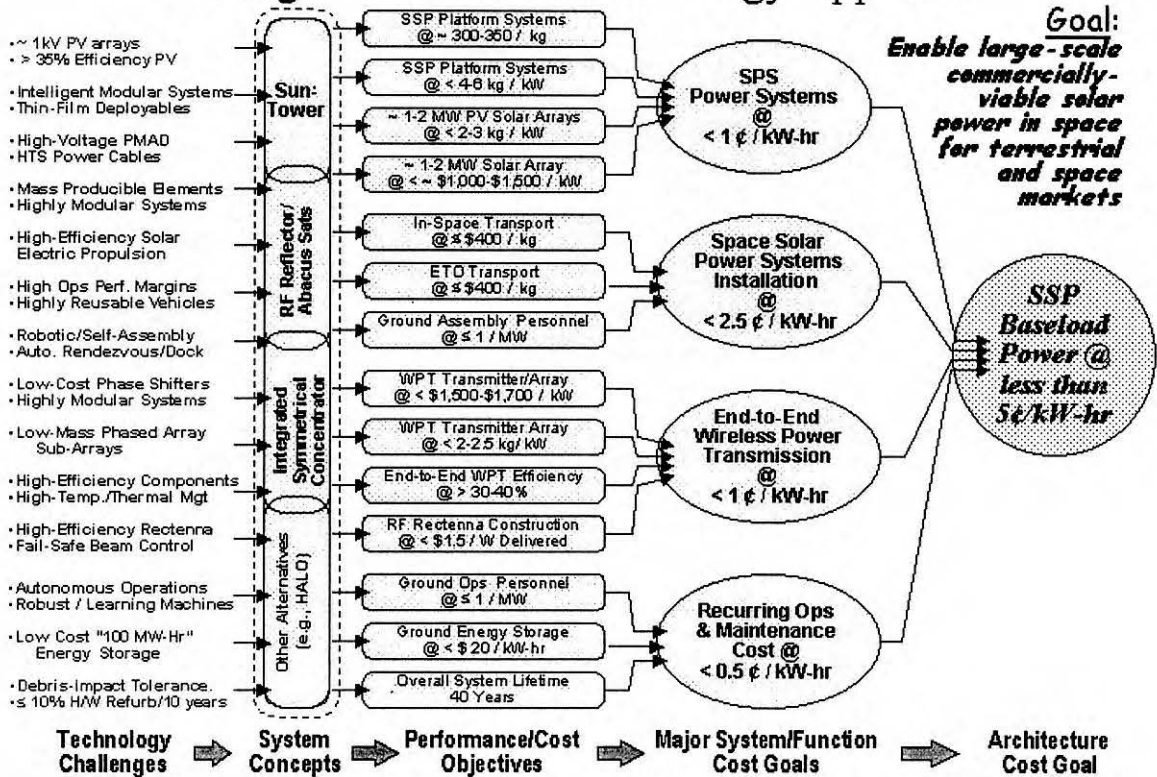

Figure 6 Research and Technology Approach for SSP

Space Solar Power Strategic R&T Investment Strategy Level A Technology Schedule/Milestone Roadmap

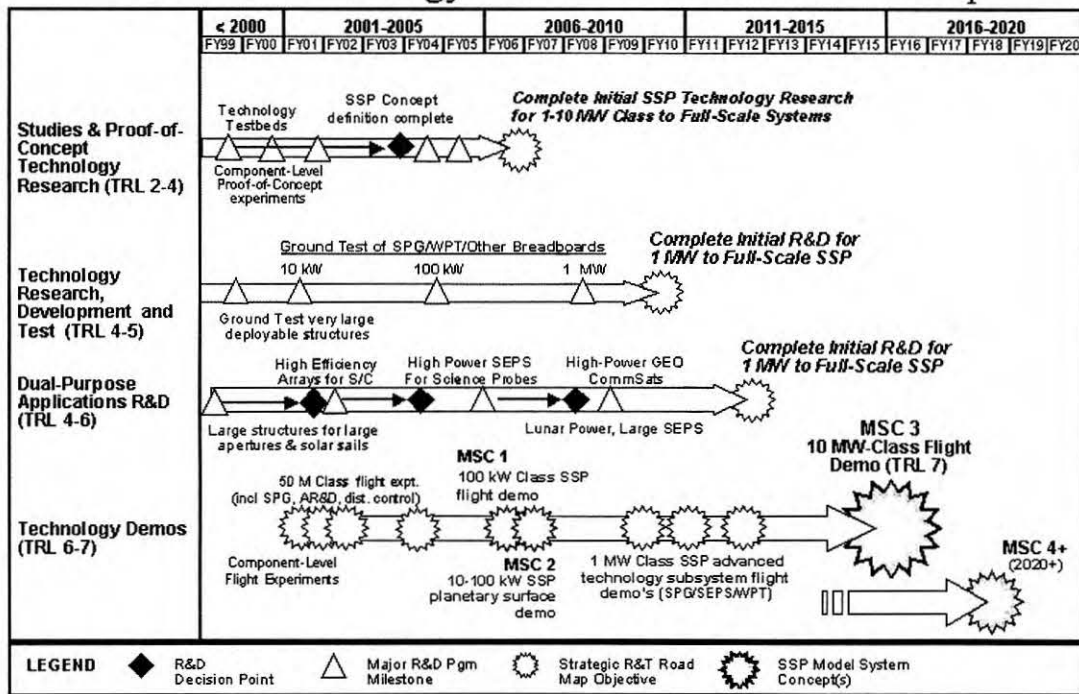

Figure 7 Technology Schedule/Milestone Roadmap

Figure 7 depicts timelines for technology demonstrations at the component, subsystem, and system level depict the relationships between the demonstrations and the MSCs. Near term technology development will advance component technologies to a TRL four. These technologies feed ground tests of major subsystems and end-to-end demonstrations. By the year 2010 the Research and Development (R&D) will be complete for a one-megawatt full-scale SSP system. Flight demonstrations will advance the SSP technologies to a TRL seven, ultimately leading to the deployment of a full-scale SPS constellation sometime after the year 2020.

Notice there will be several dual-purpose applications along the way. A few examples listed on Figure 7 include high power communication satellites, lunar power systems, solar sails and SEP. People developing conceptual designs for human space colonies and space manufacturing

system may find the SERT products useful in developing their own strategic roadmaps. For example, a space-manufacturing strategic plan could define a commercial crystal growth payload for POD 1.1. A second payload on the roadmap could be a robotic lunar manufacturing plant prototype for POD 3.1. Also, an experimental mass driver could derive from POD 3.1 based on data received from the mission depicted in Figure 3.

Technologies

This section presents examples of R&D activities for key SSP technologies. Performance goals for these technologies were driven by the goal allocations derived from the over-all system R&T approach.

Solar Power Generation

Dramatic advances in Solar Power Generation (SPG) will enable the development of large-scale SSP systems.

Challenges faced by SPG technology developers include:

- Highly efficient, low cost, mass reproducible systems for high power levels low specific mass. Ideally, modular SPG systems will enable the development of SSP systems ranging from one megawatt to one gigawatt.
- High voltage and low mass PV arrays that tolerate arcs within a relevant space environment.

Activities within SERT that addressed SPG involved the refinement of conceptual designs, examination of high voltage PV array technologies, research into concepts that promise increases in conversion efficiency as well as decreases in specific mass and demonstrations of SPG. Particular technologies included:

- Thin film solar arrays
- Multi-bandgap and concentrator solar arrays, for example the "Rainbow" concept and ultra-light weight Fresnel lens concentrators
- High voltage, e.g., one kilovolt solar array design guidelines
- Effects of hypervelocity impacts on high voltage solar arrays

Figure 8 depicts a Stretched Lens Array (SLA) Test Article from ENTECH, Inc., et.al developed under SERT. This linear Fresnel lens-based concentrator solar array has been demonstrated at the panel level in a test chamber with sunlight to voltage conversion efficiency almost 30% (about 375 watts/m²) and a power per unit mass of greater than 375 watts/kilogram.

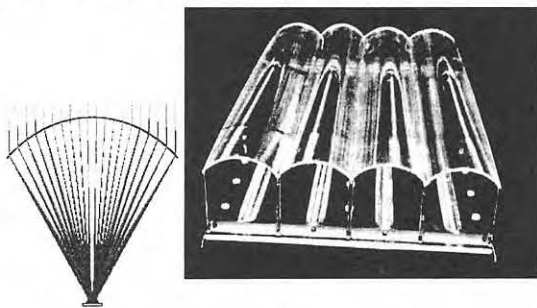

Figure 8 Stretched Lens Array

The diagram on the left side of Figure 8 illustrates the concentration of light through the Fresnel lens onto a strip of solar cells. Stands holding the thin film lens fold over flat and the entire test article folds in the middle. Requirements for efficient power generation, packaging, were considered at both the component and subsystem level. Specialists in structures, solar cells, and thin films worked together to design the SLA. This prototype is an excellent example of the importance of technology development with requirements derived from a system concept.

Wireless Power Transmission

A variety of approaches to safe and efficient wireless power transmission have been investigated, including microwave phased arrays using magnetrons or solid state transmitters, as well as visible light transmission using solid state lasers and associated optics. To assure beam safety, "center-of-beam" power intensities have been limited to the general range of 100-200 watts/m² during the SERT Program for both microwave and visible light transmission (corresponding to between 10% and 20% of the intensity of normal noon time summer sunlight).

Several WPT R&D activities in key technical areas were initiated such as:

- Light weight transmitting phased array antenna concepts
- GaN Class-E (very high efficiency at high temperature) RF amplifiers
- Circularly polarized single-plane RF rectennas

The SERT Program has conducted an important first-of-a-kind demonstration in a test chamber of the use of microwave power beaming to drive an innovative woven Carbon-filament "sail." Potential applications of this technology include robotic deep space probes and tugs for capturing asteroids. Figure 9 depicts the

microwave sail experiment conducted by Microwave Sciences, Inc.

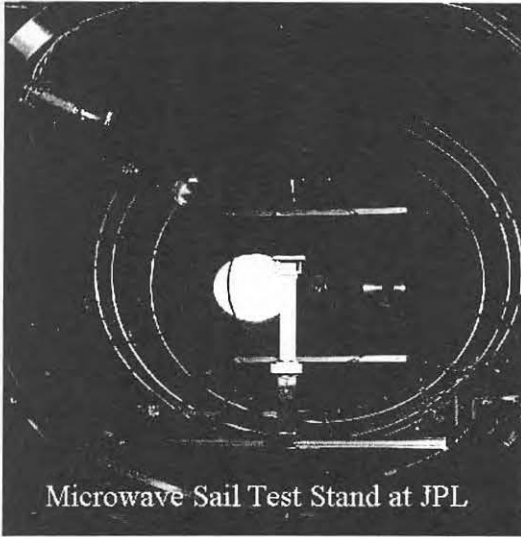

Figure 9 Testing of carbon-carbon micro-truss in a vacuum under microwave illumination

Power Management and Distribution (PMAD)

Managing and distributing power efficiently is a key technology issue for any large-scale space facility -- especially as the power levels increase and specific mass goals become more ambitious. Higher voltages present a number of challenges including:

- Drastically reduced specific mass PMAD systems ranging from 100 kW to 1 GW total system power
- Increasing high voltage and high temperature on non-superconducting PMAD options within a relevant space environment
- Viable concepts for low-mass superconducting space cables

Several SERT activities addressed the definition and refinement of PMAD conceptual designs. Innovative component technologies such as high-temperature superconductors were considered. Key component technologies were tested in a laboratory. These activities established selected characteristics for large-scale PMAD systems associated with the space

environment. Examples of some of the R&D activities include:

- DC-to-DC power converters (high efficiency, low mass, high voltage, and modular)
- High-Voltage switching SiC high-power, high-temperature semiconductors
- Integrated analysis of prototype PMAD system for a 25kW SSP power module (with or without superconducting power cables) in terms of high efficiency, low mass and modularity

Structural Concepts, Materials and Controls

Constructing large-scale space facilities like an SSP constellation, a human space colony, or a large space manufacturing facility will require a variety of structures, materials, and controls (SM&C). Some of the challenges include:

- Very light weight, ultra-large mixed structural concept systems
- Inflatable structures, kinematically-deployed structures, thin-film materials, e.g., reflectors
- Modular, robotically integrated systems
- Self deploying, robotically assembled very large structures

Specific SM&C SERT activities addressed structural concepts, structural modeling, validating key component technologies within a laboratory, and ground demonstrations. Some examples of the R&D activities include:

- Structural mechanics of rigidizable materials to optimize strength and stiffness
- Analytical tools to predict performance of inflatable structures
- Development of large, proof-of-concept, inflatable booms and trusses for solar sails, antennas, and inflatable solar arrays
- Testing of long, approximately 15 meter inflatable booms to characterize

buckling strength, stiffness and structural dynamics as functions of material properties and length/diameters (L/D)

Thermal Management and Materials

Large space facilities will require thermal materials & management (TMM) to handle high power levels and energy densities. As with other subsystems, low mass is also an important factor. Challenges faced by TMM developers include:

- High temperature and very high total load thermal management systems
- Very large, deployable thermal management systems
- Long-lived, modular and space maintainable systems

Critical TMM R&D activities addressed integrated thermal analysis and modeling and lightweight deployable radiator for high temperatures. Figure 10 depicts an inflatable deployable radiator concept developed by Lockheed Martin.

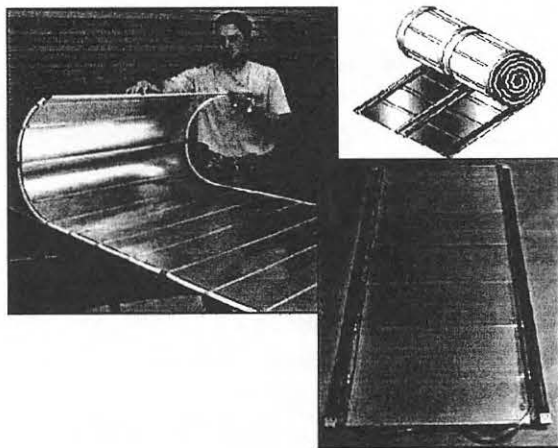

Figure 10 Inflation Deployable Radiator Concept

Robotic Assembly, Maintenance, & Servicing (RAMS)

Automated assembly of large-scale SSP systems will eliminate the risk to humans

and ultimately reduce the cost of operations. Assembly, maintenance, and servicing robots developed for SSP systems could be used for building human space colonies and large space manufacturing facilities. Several ongoing programs within NASA and other agencies have made advances at the component level. Activities within SERT for RAMS included assessing requirements of other SSP elements and applications, developing new system concepts, and validating key technologies at the laboratory level. Key R&D efforts include:

- "Sky Worker" for robotic assembly and on-platform material transport
- Small robot test article (LEMURE for inspection, repairs, etc.)
- A "Snake" robot for confined space inspection and object retrieval

Figure 11 depicts the Sky Worker robot developed by Carnegie Mellon University (CMU) and the LEMURE robot developed by Jet Propulsion Laboratory (JPL).

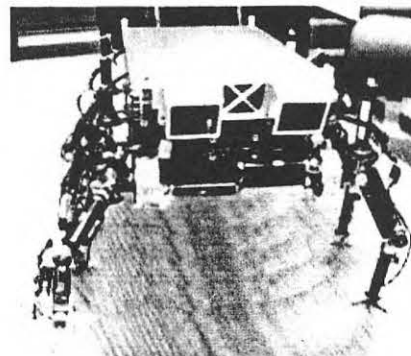
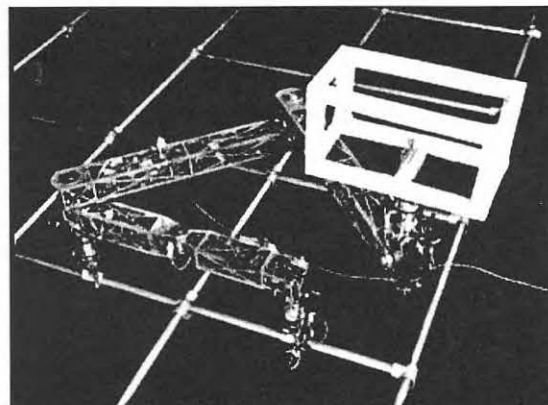

Figure 11 Sky Worker (Above) and LEMURE (Below)

