

PT-6902
CR179558

**RECTENNA TECHNOLOGY PROGRAM:
Ultra Light 2.45 GHz Rectenna
and 20 GHz Rectenna**

(NASA-CR-179558) RECTENNA TECHNOLOGY
PROGRAM: ULTRA LIGHT 2.45 GHz RECTENNA 20
GHz RECTENNA (Raytheon Co.) 98 p CSCL 20N

N87-19556

G3/32 Unclass
43648

by

William C. Brown

RAYTHEON COMPANY

Prepared for

NATIONAL AERONAUTICS AND SPACE ADMINISTRATION

NASA Lewis Research Center

Contract NAS3-22764

1. Report No. NASA CR179558		2. Government Accession No.		3. Recipient's Catalog No.	
4. Title and Subtitle RECTENNA TECHNOLOGY PROGRAM: ULTRA LIGHT 2.45 GHz RECTENNA 20 GHz RECTENNA				5. Report Date March 11, 1987	
				6. Performing Organization Code	
7. Author(s) William C. Brown				8. Performing Organization Report No. PT-6807	
9. Performing Organization Name and Address Microwave and Power Tube Division Foundry Ave., Waltham, MA 02254				10. Work Unit No.	
				11. Contract or Grant No. NAS3-22764	
12. Sponsoring Agency Name and Address National Aeronautics and Space Administration Washington, D. C. 20546				13. Type of Report and Period Covered Contractor Report	
				14. Sponsoring Agency Code	
15. Supplementary Notes Program Managers: Ira T. Myers & Jose Christian, Aerospace Technology Directorate NASA Lewis Research Center, Cleveland Ohio 44135					
16. Abstract <p>The program had two general objectives. The first objective was to develop the two plane rectenna format for space application at 2.45 GHz. The resultant foreplane was a thin-film, etched-circuit format fabricated from a laminate composed of 2 mil Kapton F sandwiched between sheets of 1 oz. copper. The thin-film foreplane contains half wave dipoles, filter circuits, rectifying Schottky diode, and DC bussing leads. It weighs 160 grams per square meter. Efficiency and DC power output density were measured at 85% and 1 kw/m², respectively. Special testing techniques to measure temperature of circuit and diode without perturbing microwave operation using the fluoro optic thermometer were developed.</p> <p>A second objective was to investigate rectenna technology for use at 20 GHz and higher frequencies. Several fabrication formats including the thin-film scaled from 2.45 GHz, ceramic substrate and silk-screening, and monolithic were investigated, with the conclusion that the monolithic approach was the best. A preliminary design of the monolithic rectenna structure and the integrated Schottky diode were made.</p>					
17. Key Words (Suggested by Author(s)) Rectenna Microwave Power Transmission Beamed Power Transmission				18. Distribution Statement Unclassified - unlimited	
19. Security Classif. (of this report) Unclassified		20. Security Classif. (of this page) Unclassified		21. No. of Pages 91	22. Price*

TABLE OF CONTENTS

<u>Section</u>		<u>Page</u>
1.0	INTRODUCTION	1
1.1	General Objectives	1
1.2	Improvement of the 2.45 MHz Thin-Film, Etched-Circuit Rectenna and Its Application to Space	1
1.3	Evolution of Rectenna Technology that Provided the Foundation for the Thin-Film, Etched-Circuit Rectenna	3
1.4	Origin of the Thin-Film Etched Circuit Concept	3
1.5	Investigation of Rectenna Design for Frequencies of 20 GHz and Greater	8
2.0	MAIN TEXT: REPORT ON TECHNOLOGY PROGRESS BY TASKS	12
2.1	Single Element Printed Circuit Rectenna (Task 1)	14
2.1.1	The Single Rectenna Element and Test Procedures for It	14
2.1.2	Determination of the Source of Inefficiency in the Original Thin-Film Etched-Circuit Rectenna Element	16
2.1.3	Establishment of Kapton F as a Suitable Dielectric Film Material	25
2.1.4	Design of the Rectenna Element Made from Kapton-F Copper Laminate	26
2.1.5	Electrical Performance of the Rectenna Element in Its Final Configuration	31
2.1.6	Diode Development and Procurement	33
2.1.7	Summary of Activity on Task 1	36
2.2	Design of a Complete Rectenna Array (Task 2)	37
2.2.1	Introduction	37
2.2.2	An Approach to a Collapsible Rectenna	37
2.2.3	Considerations Involved in Spooling the Collapsed Rectenna	40
2.3	Fabrication and Testing of a Large Area Sample Rectenna (Task 3)	43

TABLE OF CONTENTS (Continued)

<u>Section</u>		<u>Page</u>
2.3.1	Introduction	43
2.3.2	Test Arrangement and Test Results on 25 Element Rectenna Foreplane with Forced Convective Cooling	45
2.3.3	Temperature Rise of Diode in Rectenna Element as Function of Injected DC Power and Velocity of Convection Cooling Air	49
2.4	Design of an RF Test Facility (Task 4)	54
2.5	Review and Reporting Requirements	
2.6	20 GHz Printed Circuit Rectenna Study (Task 6)	57
2.6.1	Introduction	57
2.6.2	Significance of the Frequency Scale	57
2.6.3	Significance of the Consideration of Work at Even Higher Frequencies Upon the Direction of the 20 GHz Experimental Program	59
2.6.4	Discussion of the Different Approaches to a 20 GHz Rectenna	59
2.6.5	Use of Alumina Ceramic as a Microwave Circuit Substrate and as a Filler Between Foreplane and Reflecting Plane	65
2.6.6	Conclusions and Recommendations	68
2.7	Preliminary K-Band Rectenna Design (Task 7)	69
2.7.1	Introduction and Summary	69
2.7.2	Conceptual Design of a Monolithic Rectenna at 20 GHz	71
2.7.3	Matching a Dipole that is Mounted on a Ceramic or Semiconductor Substrate	79
2.7.4	Measurements of Match, Power Output, and Operating Efficiency of a 2.45 GHz Rectenna Element Mounted on a Ceramic Substrate	82
3.0	DISCUSSION OF RESULTS	83
3.1	Discussion of Results of the Program to Develop a 2.45 GHz Thin-Film Etched-Circuit	83

TABLE OF CONTENTS (Continued)

<u>Section</u>		<u>Page</u>
3.2	Discussion of the Results of the 20 GHz Rectenna Investigation	85
4.0	SUMMARY OF RESULTS	87
4.1	Summary of Results to Improve the Thin-Film, Etched-Circuit Format of the Rectenna and to Adapt it to Space Use	87
4.2	Summary of Results to Develop a Technology for Constructing Rectennas at Frequencies of 20 GHz and Above	89
	REFERENCES	91

SUMMARY

This contract had two major objectives. The first was to refine the rudimentary technology of the 2.45 GHz thin-film, etched-circuit rectenna with particular emphasis upon its space applications. The second was to examine the kinds of rectenna technology best suited for rectenna operation at frequencies of 20 GHz and higher.

The status of thin film rectenna technology at the start of the study was a single individual rectenna element made from a laminate of mylar and one ounce copper. The rectenna element was inefficient and otherwise unsatisfactory. The current study revealed why the structure was inefficient and found that a laminate of Kapton F and copper was a much better material. The proper masks were designed and individual rectenna elements fabricated. The rectifying diodes were added and the individual elements tested in a closed system where an overall efficiency of 85% was achieved.

Then arrays of up to 30 rectenna elements on one continuous laminate were constructed. These arrays were thoroughly checked for power handling capability up to 5 watts average output per rectenna element. In addition, the power handling capability of individual elements was evaluated as a function of velocity of air flow over the rectenna surface. The diode temperature was simultaneously monitored by a unique, non-invasive test instrument, the fluoro optic thermometer. From this data, reliable estimates could be made of the power handling capability of a complete rectenna array as a function of air density and air flow velocity. A 25 element section was sent to LeRC for test and evaluation.

A preliminary study was made of the deployment of the rolled up rectenna into a flat plane for space use. Various problems were investigated and several formats examined.

The study of the various approaches to fabricating a high frequency rectenna revealed that the thin-film, etched-circuit rectenna format was not a sound approach and stimulated an investigation of placing the foreplane of the rectenna on a solid dielectric substrate such as alumina ceramic. This ceramic could serve as both a separator from and a heat conducting path to the reflecting plane where heat could be removed by flow of a coolant. Further study indicated that a monolithic structure based on the use of a GaAs substrate on which both diodes and circuits were formed would be the best approach for constructing a rectenna at frequencies of 20 GHz and higher. A diode was designed for the monolithic structure, and theoretically evaluated in terms of efficiency and power handling capability. An initial design of a monolithic rectenna was carried out.

1.0 INTRODUCTION

1.1 General Objectives

The contract had two general objectives. The original objective dealt exclusively with the development of the thin-film, printed-circuit rectenna for space use at a frequency of 2.45 GHz. A principal part of this objective was concerned with improving the basic properties of a rectenna format that had resulted from earlier embryonic efforts to develop a thin-film rectenna. The second general objective, which was the subject of a contract extension, was to examine the application of the rectenna principle to high frequency rectennas at 20 GHz and above.

For purposes of discussion it will be desirable to handle these two objectives separately. The first objective, that having to do with the improvement of the 2.45 GHz rectenna and its application to space will be discussed first.

1.2 Improvement of the 2.45 MHz Thin-Film, Etched-Circuit Rectenna and Its Application to Space

The more detailed objectives of the work carried out under this subject are described in the first four items in the statement of work given in Section 2.0. In the introduction we will discuss the work in more general terms.

The approach to carrying out the task was based upon an extension of an approach introduced under NASA contract NAS6-3006(1). This approach was based upon the use of conventional thin-film printed circuit technology, in which all elements of the circuitry, excluding the rectifying diode and the reflecting plane, were "printed" on the two surfaces of the film without the necessity of any interconnects between the circuitry on the two surfaces. This fabrication method is consistent with the objective of producing very large areas of the rectenna at a low cost per unit area and with a high ratio of power output to mass of the structure.

However, the technology for the thin-film rectenna had proceeded only to the point of making and testing individual elements made from a laminate composed of mylar covered with thin sheets of copper. The efficiency was much less than expected, and the mylar was very vulnerable to both ultra violet degradation and high temperature operation.

The general work effort related to this first general objective consisted of analyzing and refining the thin-film, etched-circuit rectenna at the single rectenna element level for use in space and then fabricating relatively large areas of the rectenna for evaluation and test. Another aspect of the work related to storage of the rectenna while enroute to space and the deployment of it in space. Still another aspect was the aid given to LeRC in the design of a facility for testing the rectenna.

The results of the effort to improve the rectenna in a format more suitable for space were very successful. It was found that the use of Kapton F material as the core of the laminate material greatly extended the permissible operating temperature as well as making the rectenna highly resistant to deterioration from ultra violet radiation. In addition it was determined that Kapton F greatly reduced the losses that were inherent in the mylar itself as well as in the lossy adhesive used to join the mylar to the copper.

One of the interesting developments related to the diode rectifier. No portion of the rectenna is more important than the diode. Fortunately, the basic development of the diode had already taken place during earlier rectenna work. The rectifier is a Schottky barrier diode that utilizes GaAs as the semiconductor material. The series resistive loss in this material is much less than that of silicon, the only other candidate material, so it is considerably more efficient. The diode also uses a heat sink that is fabricated on the metallic side of the Schottky barrier to provide a low impedance path for heat flow from the active and heat generating portion of the diode.

The packaging of the diode has taken several formats. The first successfully used package was of the ceramic pill type. In the interests of greatly reducing the production cost of the diode for use in the Solar Power Satellite application a glass packaging technique was introduced. It had been expected to use this packaging format for the thin-film rectenna; in fact, it was used in the early phase of the work effort. However, the tooling for the glass diode became unavailable and it was necessary to shift back to a ceramic package. On subsequent analysis it was discovered that the thermal conduction from such a package is about twice that from the glass diode so that heat is conducted more efficiently to the printed circuit which presents the surface from which the heat is radiated to space. The result is that the power handling capability of a rectenna built from such diodes is considerably better than anticipated, resulting in the prospect of the rectenna working at considerable higher power density in space than originally anticipated.

It was not feasible within the constraints of the contract funding to test the rectenna in vacuum. However, the opportunity did arise to check the rectenna under known rates of a convective flow of air, while simultaneously monitoring the temperature of the diode. The results of this investigation were important in feasibility studies of microwave powered aircraft that would fly at high altitudes where the air was much less dense but where the aircraft flight speeds resulted in convection cooling rates similar to those taken in the laboratory under sea level air conditions. Furthermore, one data point in the studies was for zero convective air flow. Even under these conditions the temperature rise in the diode remained below 100°C for two watts of DC power output per rectenna element and diode.

It was possible to make the interesting results of this experimental evaluation of the power handling capability and efficiency of the thin film rectenna publicly available in a timely fashion through two oral presentations

and printed papers at two international microwave symposia.^(2,3) The technological approach as well as the test results were described in these papers.

The work carried out under this portion of the contract brings the thin-film, etched-circuit rectenna to a high level of maturity, available for aircraft applications and serious consideration for space use. There are problems remaining, however. One is the radiation of harmonics. In addition the generation of spurious signals having to do with parametric oscillations in the rectenna have unexpectedly been found. This is the first known incidence of such parametric oscillations in rectennas after many years of development and application so that they are probably the function of the particular design of the rectenna. This is a phenomena that will need attention in future activity.

1.3 Evolution of Rectenna Technology that Provided the Foundation for the Thin-Film, Etched-Circuit Rectenna Concept

The thin-film, printed-circuit rectenna approach to be described in this report has evolved directly from the circuit format used in the conventional rectenna in response to a need for a lower cost, lighter weight, and more flexible rectenna that will operate efficiently at relatively low power levels. There have been several distinct steps in the technological evolution.^(4,5)

The first step involved a transition from a three plane rectenna construction format as shown in Figure 1-1 to a two plane format shown in Figure 1-2 and 1-3 in which nearly all of the rectenna functions are carried out on the foreplane.⁽⁶⁾ A physical realization of this is shown in Figure 1-4. The second step in the evolution involved redesigning the rectenna element to operate at a higher impedance level to retain good efficiency at relatively low incident microwave power densities that were felt to be desirable for rectennas in the upper atmosphere, in space, or at the edges of the rectenna for the solar power satellite concept.⁽⁷⁾

1.4 Origin of the Thin-Film Etched Circuit Concept

The factor that led directly to active work on the thin-film printed-circuit concept was the need expressed by personnel at the Wallops Flight Facility for a flexible rectenna that could be used at an altitude of 70,000 feet and at reasonably low power density levels on a balloon. The latter requirement suggested the use of the electrical circuit previously developed in a bar type construction format as the electrical circuit prototype for the thin-film printed-circuit rectenna.^(1,6)

The transformation of the mechanical design of the rectenna element from the bar-type format to the thin-film format represents a different and perhaps unique approach to printed circuit design. The foreplane is a balanced circuit that does not use a ground plane (the reflecting plane, located a quarter wavelength behind the foreplane, is not a ground plane in the "slot-line" sense). The mechanical design of the thin-film format seeks to simplify

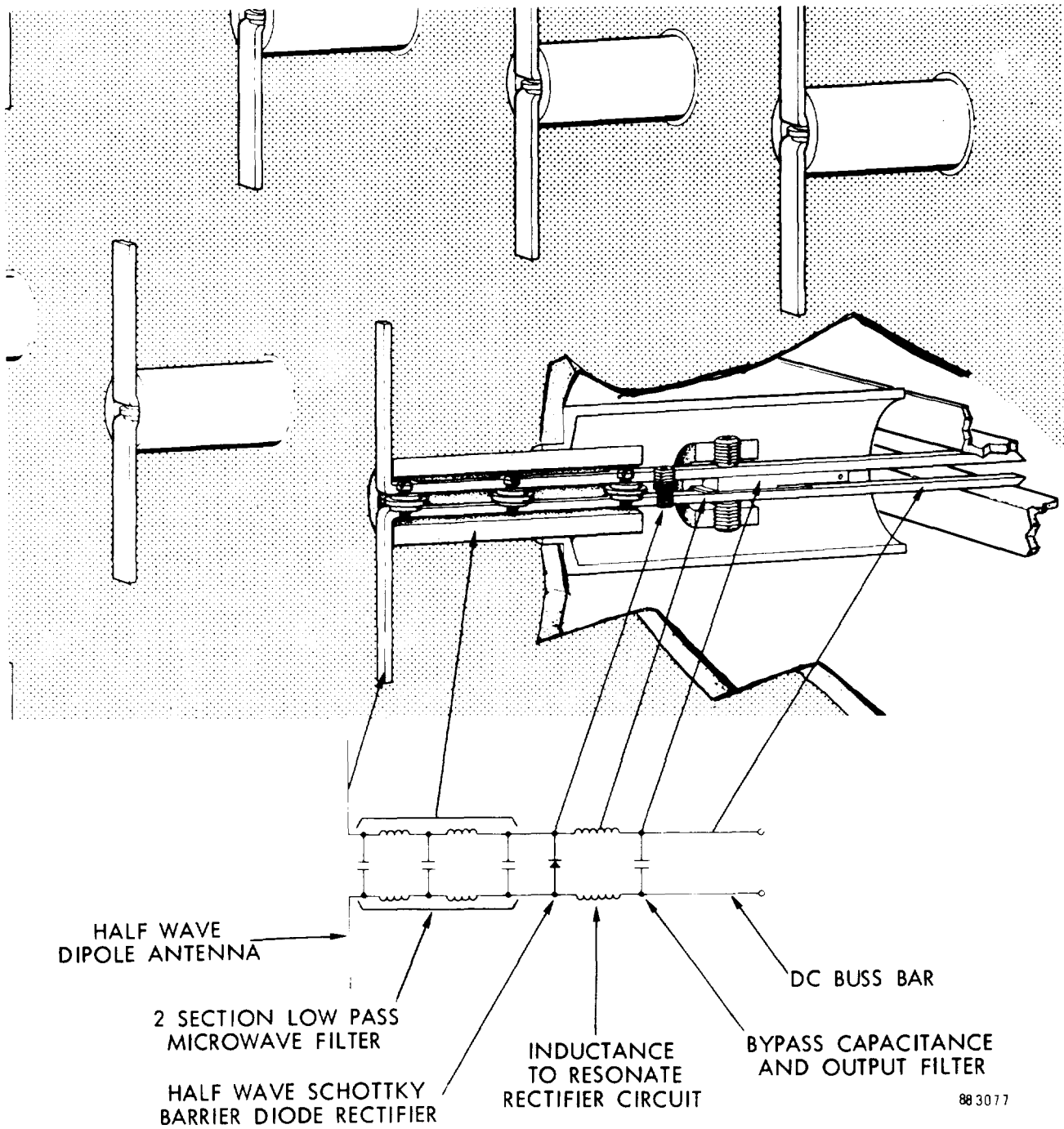

Figure 1-1. The Three Plane Rectenna Construction Consisted of (1) the Plane of the Half Wave Dipoles, (2) the Plane of the Reflecting Surface, and (3) the Plane of the DC Bussing Function. The Filtering and Rectification Functions of the Elements Ran Transverse to these Planes.

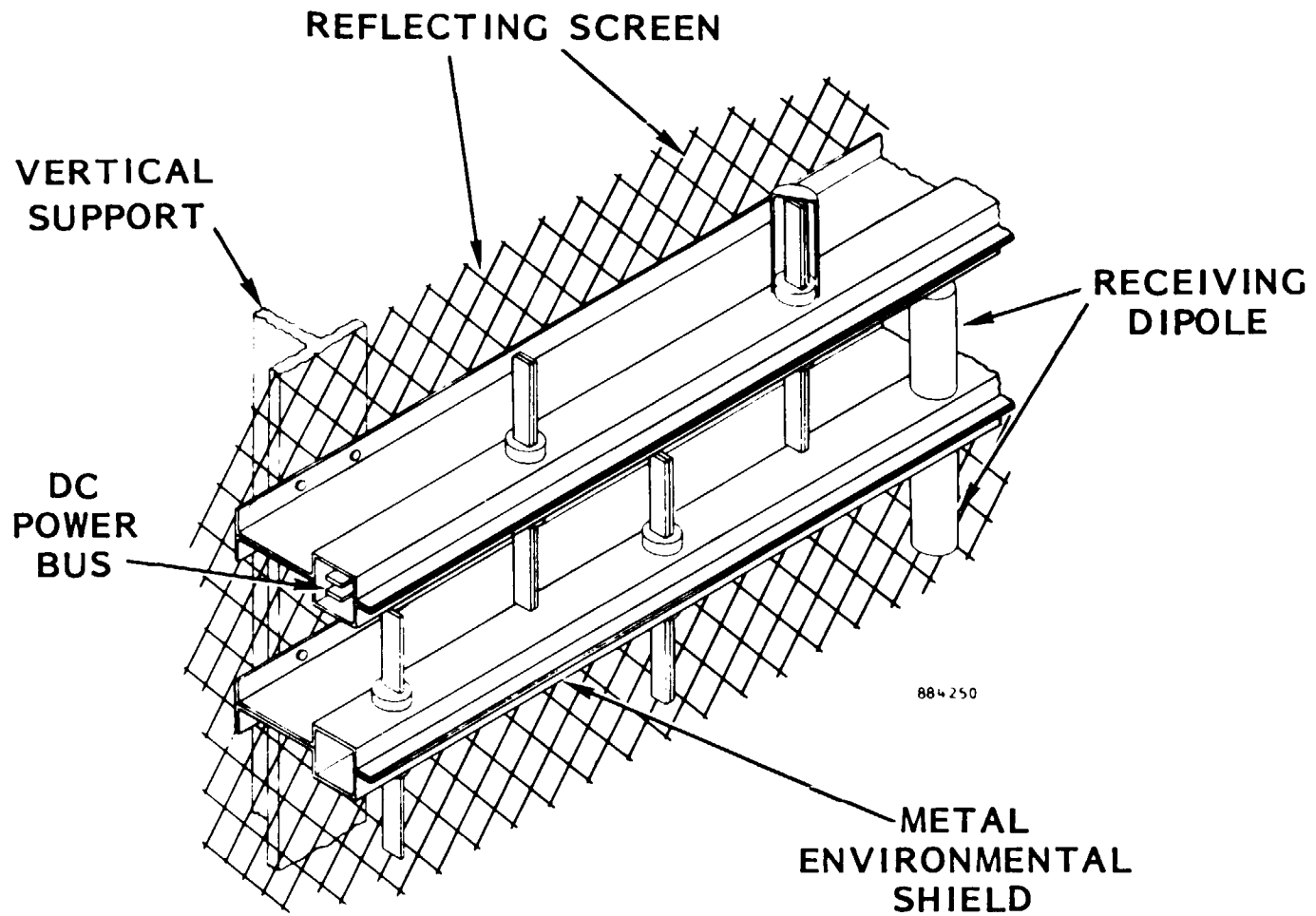
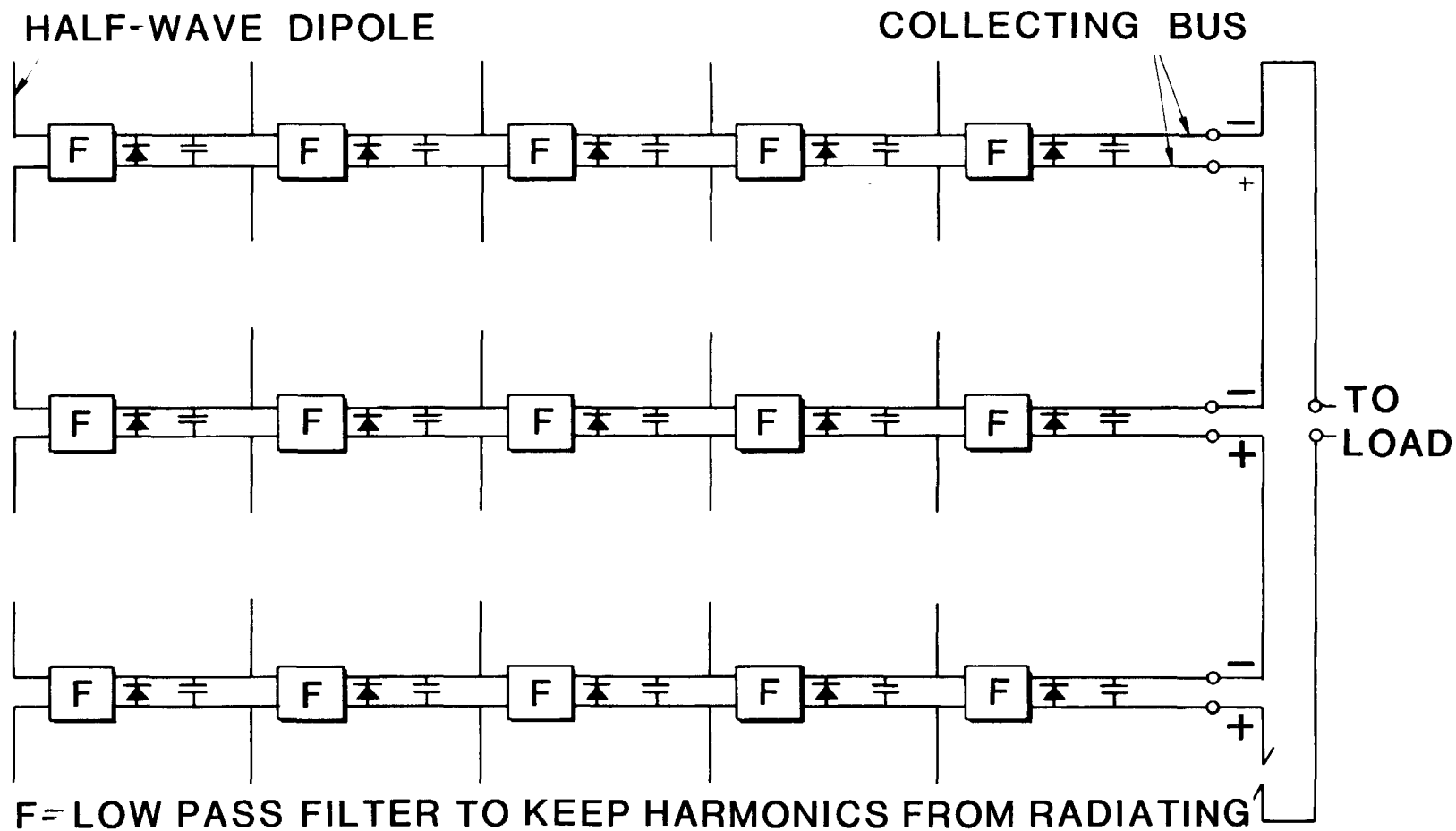
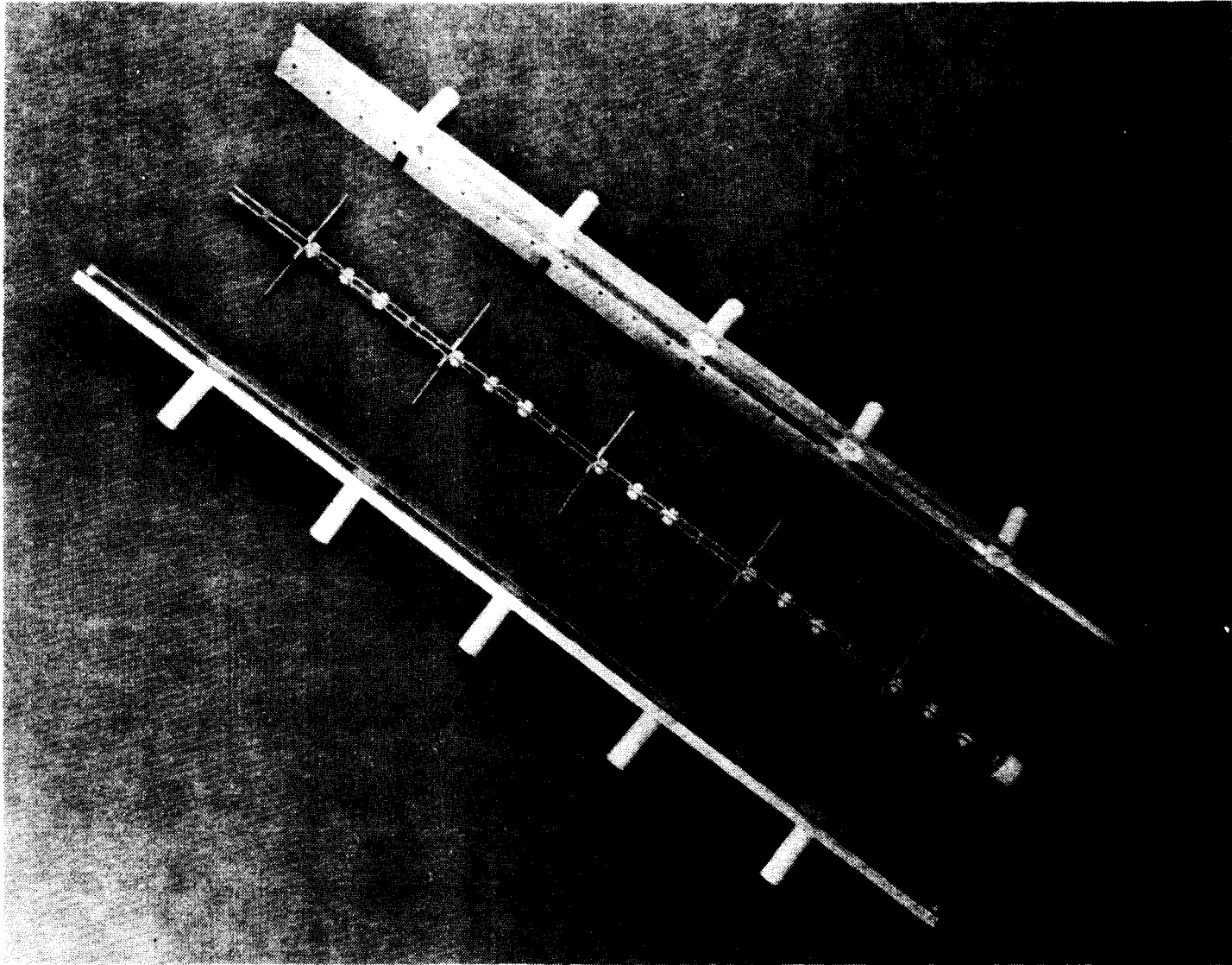

Figure 1-2. The Reorientation of the Rectenna Elements into a Two Plane Construction Format Grew out of the Necessity for a More Economical Construction Approach for the Solar Power Satellite Concept.



715745 -1

Figure 1-3. Schematic Diagram Showing the Functions Performed on the Foreplane of the Two Plane Rectenna Construction Format. These Functions are (1) Collection of the Microwave Energy by the Half-Wave Dipoles, (2) the Low Pass Filter Function, (3) the Rectification and Ripple Removing Functions, and (4) the DC Power Bussing Function.



76-78474

Figure 1-4. The Item of Interest in this Photograph is the Connection of the Bar-Type Rectenna Elements into a Linear, Planar Structure, to Function as the Foreplane of the Two Plane Structure. This Format was Checked Out Electrically in Considerable Detail During a Previous Study. Shown also are the Environmental Shields, Not Needed for Space or High Altitude Atmospheric Platform Applications of the Rectenna.

ORIGINAL PAGE IS
OF POOR QUALITY

PT-6902

fabrication by the elimination of any connections such as plated feed-throughs between the microwave circuits on the two sides of the film. It does this by etching the dipole antenna, the inductive sections of the low pass filters, and the DC bus bars on the top surface of the thin film. On the other surface the copper is etched to leave just enough material to form the capacitors associated with the low pass filters and the DC blocking capacitor. Figure 1-5 illustrates this arrangement.

Using this approach, a thin-film, etched-circuit rectenna was fabricated from a sandwich material consisting of one mil mylar bonded with an adhesive to one ounce (1.5 mil) copper on both faces. The resulting product is shown in Figure 1-6.

The electrical tests made upon a rectenna element cut from the larger sheet and tested with the special fixture to be described later indicated a moderate level of success but its efficiency was considerably lower than expected. Mylar as a base material also had the deficiencies of a relatively low softening temperature and of being sensitive to deterioration from ultra violet light.

The work performed under this LeRC contract may be considered as a major step in the evolution of the thin-film, printed-circuit rectenna. It has concentrated upon making the rectenna element (and therefore the rectenna) more efficient, and upon the use of plastic materials better suited for space application than mylar. The effort has also involved additional diode development which will favorably impact the performance of the rectenna.

1.5 Investigation of Rectenna Design for Frequencies of 20 GHz and Greater

Tasks six and seven of the work statement deal with investigating the rectenna principle at much higher frequencies and examining in some detail the design of a rectenna at 20 GHz.

The pursuit of these tasks was necessarily based upon the rectenna technology that had been developed at 2.45 GHz. However, it was found that a rectenna designed by simply scaling the rectenna from its 2.45 GHz thin-film, etched-circuit format did not appear attractive at such high frequencies because of a host of problems. Perhaps the most serious one was the large number of rectenna elements per unit area, because their density scales as the square of the frequency. Even if small diodes could be constructed in large numbers economically, the problem of assembly and carrying heat away from the diodes remained.

Because of scaling problems having to do strictly with the scaling of the thin-film circuit the use of a substrate on which the circuits could be silk screened became attractive. The standard substrate for such silk screened films is alumina ceramic. But alumina is a fair, if not good, conductor of heat so that filling the space between the foreplane and reflecting planes with

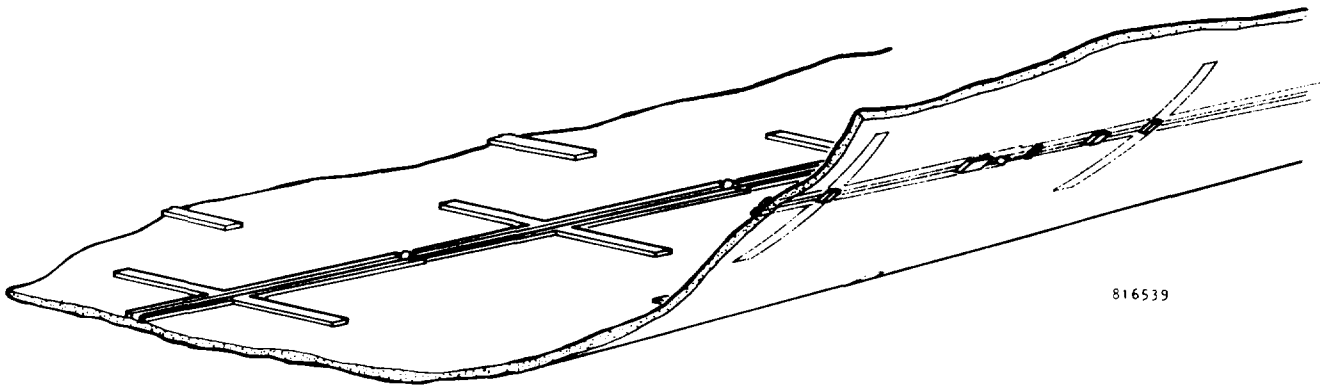

Figure 1-5a. Principle of the Thin-Film, Etched-Circuit Rectenna. Circuit Elements are Etched on Both Sides of Dielectric Film. There are No Interconnects between Etched Elements.

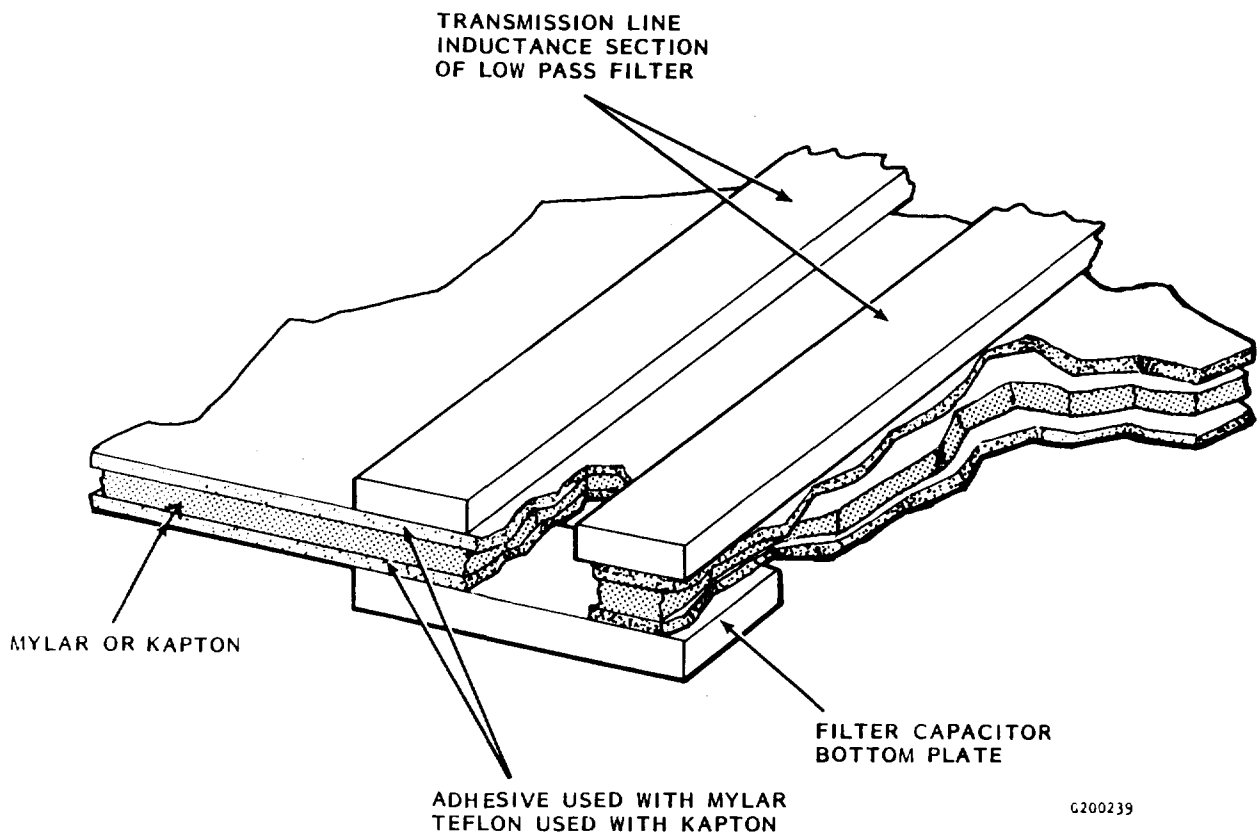

Figure 1-5b. Cutaway View of Rectenna Element Construction in Region of Capacitor for Low-Pass Filter Section. Low Dielectric Losses in the Film and Adhesive are Critical to High Efficiency. First Thin-Film Rectenna Used Mylar Dielectric and Adhesive Both of which have High Loss. Greatly Improved Rectenna Uses Kapton with Teflon as Adhesive.

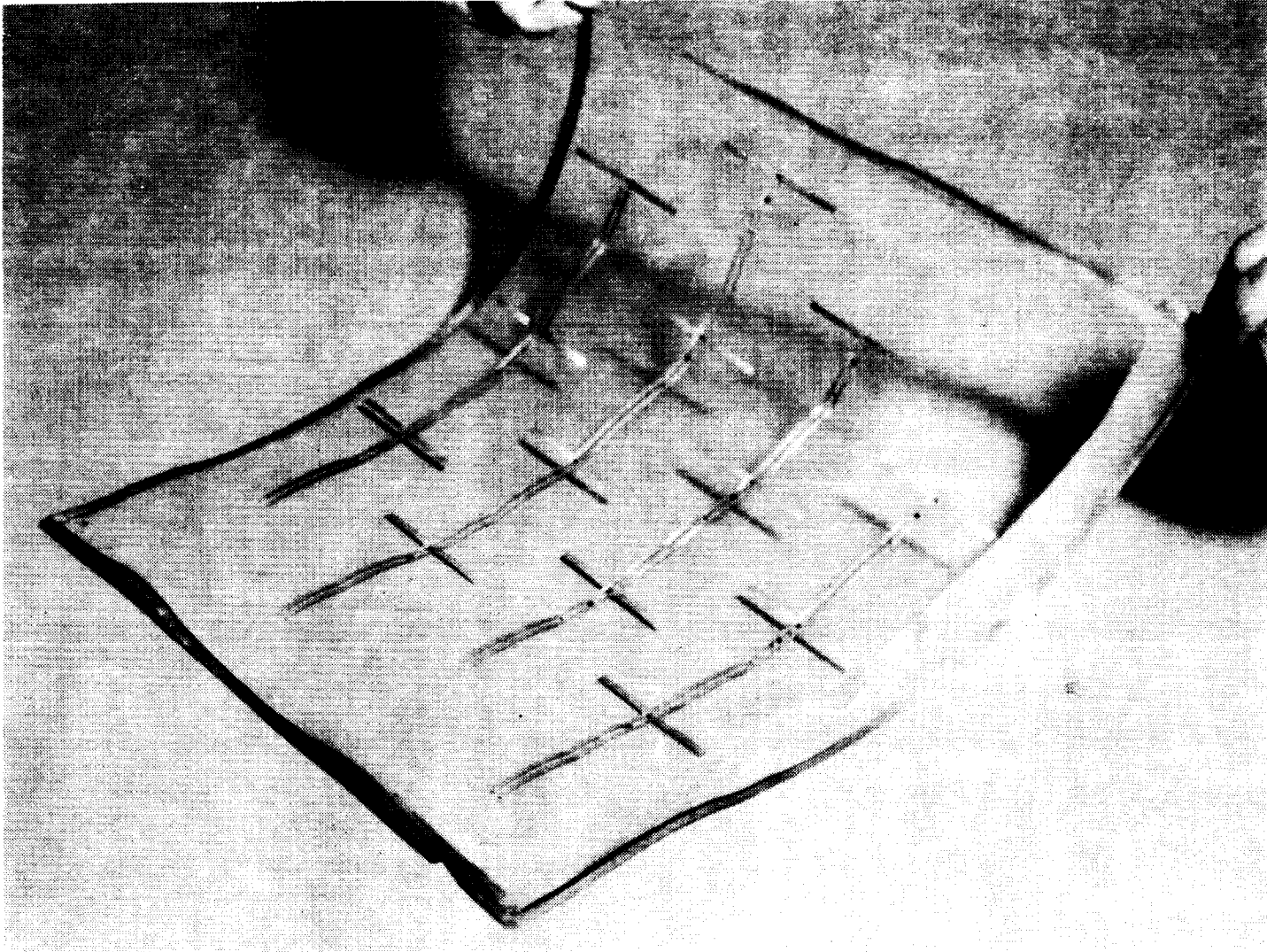

Figure 1-6. Photographs of the First Thin-Film Printed-Circuit which Forms the Foreplane of the Rectenna. The Dielectric Substrate Used was Mylar which was Found to have Several Shortcomings as a Substrate for a Thin-Film Rectenna.

79-84620

ORIGINAL PAGE IS
OF POOR QUALITY

PT-6902

alumina ceramic would be an attractive solution to the problem of cooling an array. Cooling surfaced early as a problem because a high frequency rectenna must operate at a high power density to be efficient, and a combination of the higher density and the lower efficiency of a high frequency rectenna necessarily generates a large amount of waste heat per unit area.

Because alumina has a high dielectric constant of about nine, it also became evident that the half wave dipoles of the rectenna would become considerably shorter with the result that there would be more elements per unit area. But it was noted that any development involving a silk screened circuit on an alumina ceramic would be also applicable to a semiconductor substrate of silicon or GaAs which have about the same dielectric constant as alumina.

Over the time period that the contract was active, the technology of monolithic GaAs circuits had advanced so rapidly that at the time this report is being written the prospects of being able to build a monolithic rectenna on a wafer of GaAs became a reasonable possibility. For the future, a completely monolithic circuit is very attractive.

If the development of such a rectenna were begun now there would probably be a significant percentage of the diodes that would be inoperative, perhaps as high as ten percent, because of the imperfect nature of the GaAs wafer technology. However, the monolithic rectenna circuit could be so designed to tolerate the failure of such a percentage of the diodes. And over the near future it is expected that the quality of the GaAs substrate, which is a basic problem in much more complicated and currently much more important monolithic circuits, will be rapidly improved.

Ten years ago, there appeared to be no need for a high frequency rectenna because no high power cw transmitter technology existed at these frequencies. That situation has changed dramatically. The introduction of the gyrotron electron tube assures the availability of several hundreds of kilowatts of cw power at 20 to 35 GHz. And large mechanically-steerable 70 meter parabolic reflectors are being readied to be used with such tubes for deep space radar purposes. It is logical to expect that these breakthroughs in technology will be examined for their application to power transmission. The interest in rectennas for this application may be expected. It would be timely to consider undertaking monolithic rectenna developments at this time, even though there are still imperfections in GaAs technology.

2.0 MAIN TEXT: REPORT ON TECHNOLOGY PROGRESS BY TASKS

There were seven tasks to be performed under this contract. The report on technology progress will be by task as outlined in the work statement of the contract with the exception of Task 5 which is the Review and Reporting Requirement. As indicated in the Introduction there were two main objectives, one associated with further development of the thin-film, etched-circuit rectenna at 2.45 GHz and the other associated with an extension of rectenna technology to much higher frequencies at 20 GHz and beyond.

The first four tasks are associated with the first general objective. Tasks 6 and 7 are associated with the second objective. The work statements associated with all of these tasks are presented below.

Task 1 - Single Element Printed Circuit Rectenna

The Contractor shall investigate and define the microwave and printed circuit design techniques that will be used to fabricate a single element printed circuit foreplane rectenna for evaluation. Using existing rectenna models, the Contractor shall establish electrical and mechanical requirements for the solid state component, and address thermal requirements for operation of the element in a vacuum environment.

The fabrication of the rectenna element shall include three recyclings of the artwork: the first to include the output bypass capacitor, and the second to fine tune the design, and the third to optimize the efficiency. Performance testing to determine such factors as efficiency, line and load characteristics, transient response, and standing wave ratios would be confined to a single element.

Task 2 - Design of a Complete Rectenna Array

The Contractor shall investigate the design of a combined foreplane, reflecting plane, and a separator. As part of the effort, methods of deploying a printed circuit rectenna array shall be considered. Mechanical, electrical, and thermal characteristics of various separator configurations shall be addressed.

After examining the various approaches, the Contractor shall select the "best" design and fabricate a small section of the combined array. This combination array shall consist of five foreplane structures without microwave diodes mounted on the substrates. No electrical testing will be performed on this combined array section.

Task 3 - Fabrication of a Large Area Sample Rectenna

Using the results of Tasks 1 and 2, the Contractor shall fabricate two sample rectenna structures less than 0.2 M^2 suitable for operation in vacuum.

This array shall be tested electrically in an ambient environment. After passing the electrical performance check, the sample rectenna array shall be sent to Lewis Research Center for operational tests in both ambient and vacuum environments.

Task 4 - Design of an RF Test Facility

The Contractor shall provide a suitable design for an rf test facility to be built at Lewis Research Center. The critical component requirements and performance specifications of the major rf excitation equipment and microwave measurement equipment shall be specified. As part of this task, the Contractor shall recommend rf components and advise the NASA Project Manager during the fabrication of the Lewis microwave test facility.

Task 6 - 20 GHz Printed Circuit Rectenna Study

The Contractor shall investigate the feasibility of developing a rectenna element capable of performing in the K-band region. This order of magnitude increase in operating frequency will allow the physical size of the rectenna to be reduced accordingly.

The study shall include, but not be restricted to, the effects of dielectric loss, semiconductor performance, diode technology, critical design parameters, and photoetching/layout techniques.

Task 7 - Preliminary K-Band Rectenna Design

The Contractor shall investigate and define the microwave and printed circuit design techniques that would be necessary to realize a K-band printed circuit foreplane rectenna.

This design will include the selection of an operating frequency/substrate combination as to optimize the element's performance, specification of the proper rectifying diode, and preliminary artwork of the complete rectenna.

2.1 Single Element Printed Circuit Rectenna (Task 1)

This section will be organized by first establishing what the single rectenna element is and how it is tested. This will be followed by an account of finding the causes for the unexpected inefficiencies in the first rectenna elements made under NASA contract NAS 6-3006. This, in turn, will be followed by an account of developing a highly efficient rectenna element that is also greatly improved from the point of view of power handling capability and durability by a change in the film material.

2.1.1 The Single Rectenna Element and Test Procedures for It

Historically, rectenna development has proceeded by a test procedure that allows a detailed evaluation of a single rectenna element in a closed system that simulates the cell area that the element occupies in the rectenna. By this procedure, an accurate measurement of its efficiency can be made, and its impedance as seen by the incoming microwave beam closely approximated.

In the two plane format the rectenna element consists of a repetitive unit of the rectenna foreplane as shown, for example, in Figure 1-3 together with the metallic reflecting plane which is positioned about one quarter wavelength behind the foreplane section. The repetitive unit of the rectenna foreplane (Figure 1-3) consists of halfwave dipole antenna that couples to the incoming microwave beam or to incident microwave power in the special test fixture to be described later. The power from the antenna flows into a two section low pass filter which serves the dual function of energy storage for the half wave rectifier which follows it, and to attenuate the flow of harmonic power from the rectifier to the antenna. The rectifier is shunted across the output terminals of the low pass filter and its capacitance resonated out by a short section of transmission line which is terminated by a large bypass capacitor. The capacitor serves both as an effective short circuit termination of the transmission line and as a capacitor filter to minimize any microwave ripple on the DC power output of the element. The DC power output is collected on the two conductor strips that connect one element with another. The conductor strips serve a dual function of collecting the DC power as well as functioning as inductive sections of microwave transmission lines within the rectenna element itself.

The properties and performance of the rectenna element as just described is presented in great detail in References 1 and 6, including detailed mathematical modeling and computer simulation of performance that provides information on current and voltage waveforms, efficiency, harmonic content, etc. Reference 1 provides design procedures for the filter sections. It will not be the purpose of this report to go into similar detail.

For testing purposes the rectenna is mounted on a hinged door as shown in Figure 2-1. The door becomes part of an expanded waveguide test fixture shown in Figure 2-2. In turn the fixture becomes part of a closed measurement

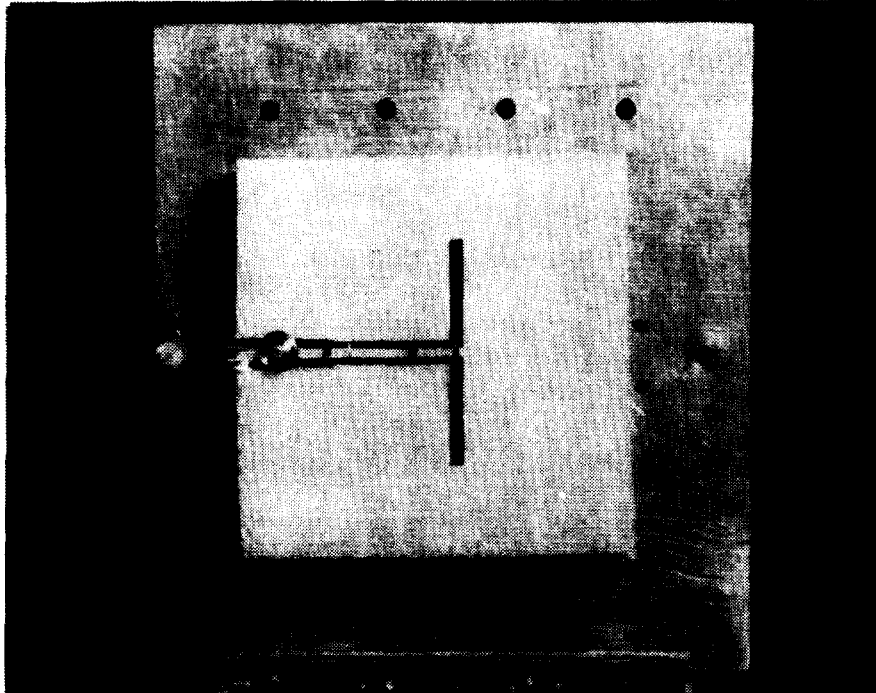

80-1035 C

Figure 2-1. Thin-Film Printed Circuit Element Shown in Test Position Mounted on a Hinged Door and Ready for Test.

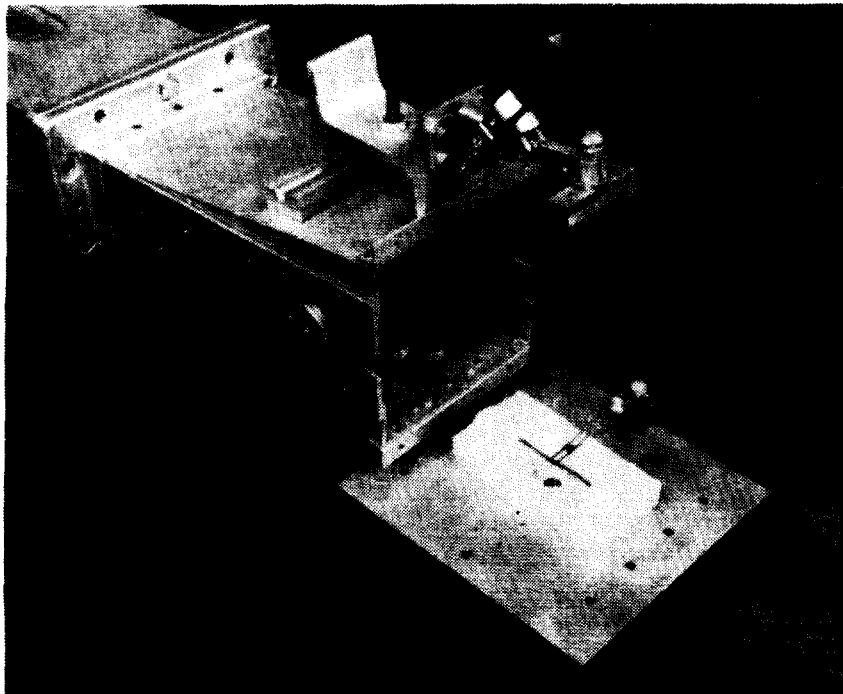

79-84458

Figure 2-2. Test Fixture for Testing an Individual Rectenna Element. During Test Door is Closed to Constitute a Closed System Check of the Rectenna Element as Shown in Figure 2-4.

system shown in Figure 2-3 in which accurate measurements of incident microwave power, reflected microwave power, and DC power output can be made.

Efficiencies can be computed from the measurements of the parameters shown in Figure 2-4. Efficiency may be stated in terms of overall efficiency defined as the ratio of DC power output to incident microwave power, or, electronic efficiency defined in terms of the ratio of DC power output to the microwave power absorbed in the rectenna element.

Measurements are also frequently made of the impact that DC load resistance and the microwave power input level have upon the input impedance level to the rectenna as measured at or near the plane of the foreplane. This information can be plotted on a Smith Chart.

Special attention is given to the validity and accuracy of the measurements. An effort is made to calibrate the microwave input accurately. This includes the elimination of the impact of harmonics in the calibration procedure by the use of low pass filters placed between the microwave generator and the system to be calibrated. Harmonic filters are also placed to eliminate the impact of harmonics generated by the rectenna element upon both the directional coupler with its power meter and the standing wave detector. Details of the system are given in Reference 6.

2.1.2 Determination of the Source of Inefficiency in the Original Thin-Film Etched-Circuit Rectenna Element

The first thin-film, etched-circuit rectenna element was modeled from a bar type rectenna element shown in Figure 2-5. Data on this element is given on pages 56 and 57 of Reference 6. The performance of this bar type rectenna with respect to efficiency as a function of microwave power absorbed is shown in Figure 2-6. Reflected power was so low that efficiency as function of incident power would have been nearly as high. The corresponding performance of the thin-film, etched-circuit rectenna element developed under the Wallops Flight Facility Support (Reference 1) is shown in Figure 2-7. There was a substantial difference in efficiency amounting to 13% between the anticipated efficiency and that which was experimentally measured.

Normally, a difference in efficiency of 13% could be tolerated. However, in the solid bar model case the inefficiency was 16% while in the first thin-film model it was 29% or almost twice as great. The power handling capability of the rectenna element will be determined by the power it must dissipate and dissipation must be by means of radiation alone if the element is in the vacuum of space. The application for the thin-film rectenna as stated in this study was to be in space. Moreover, the melting temperature of mylar from which the first element was made is relatively low, making dissipation an even more critical factor.

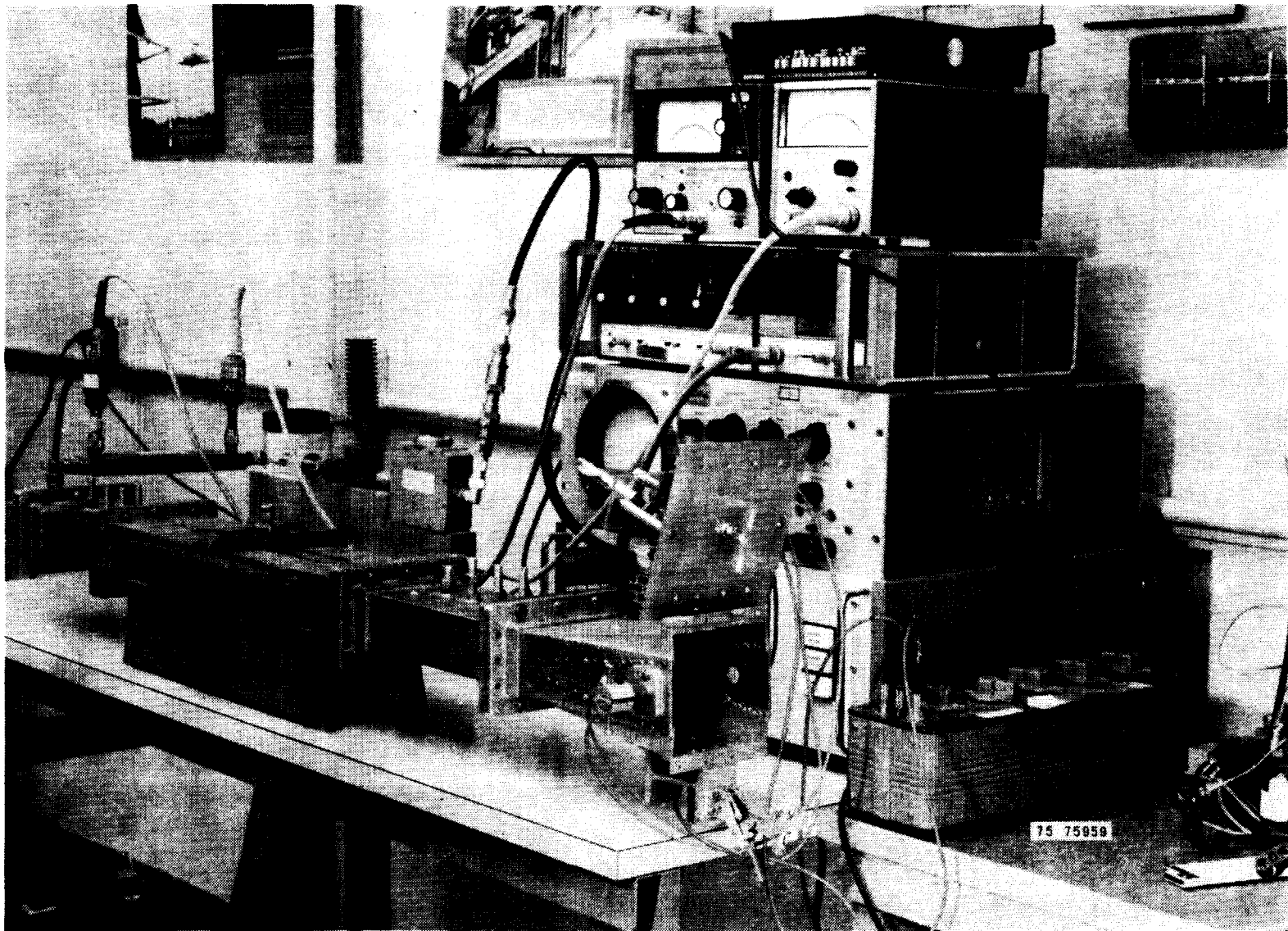

Figure 2-3. The Complete Rectenna Element Test Arrangement Utilizing the Expanded Waveguide Fixture.

ORIGINAL PAGE IS
OF POOR QUALITY

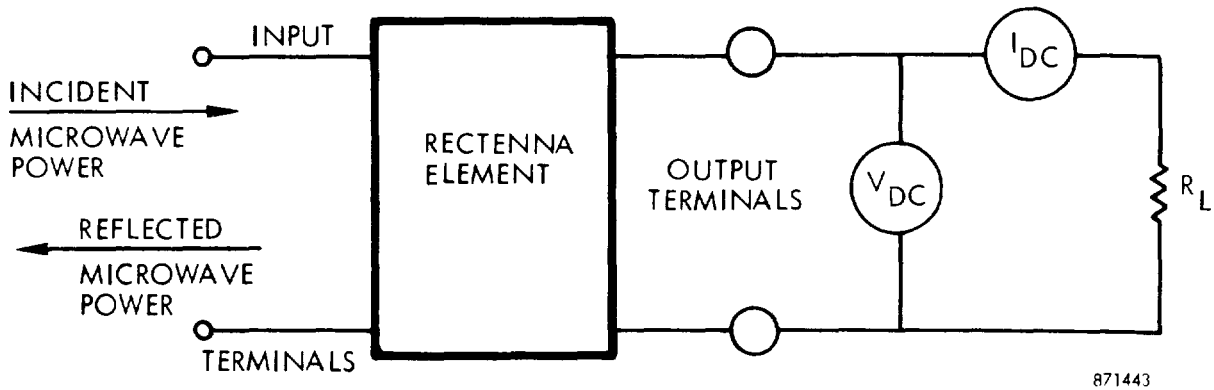
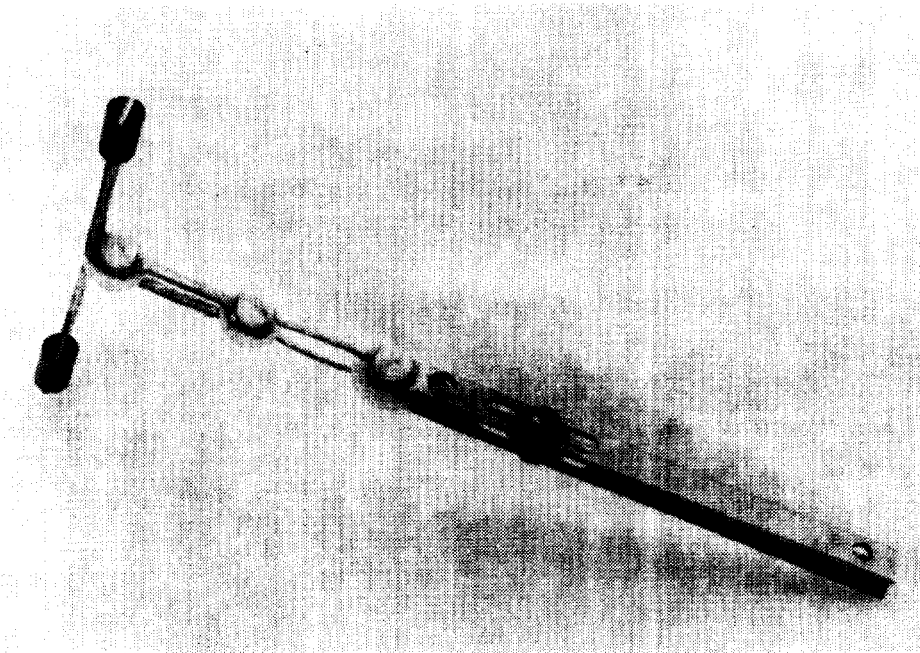

Figure 2-4. Input-Output Characterization of the Rectenna Element Showing the Measurements that can be Made to Compute the Efficiency.



77-78992

Figure 2-5. Special High Impedance Bar Type Rectenna Element that Served as a Model for the Circuit Design of the Thin-Film Printed Circuit Element.

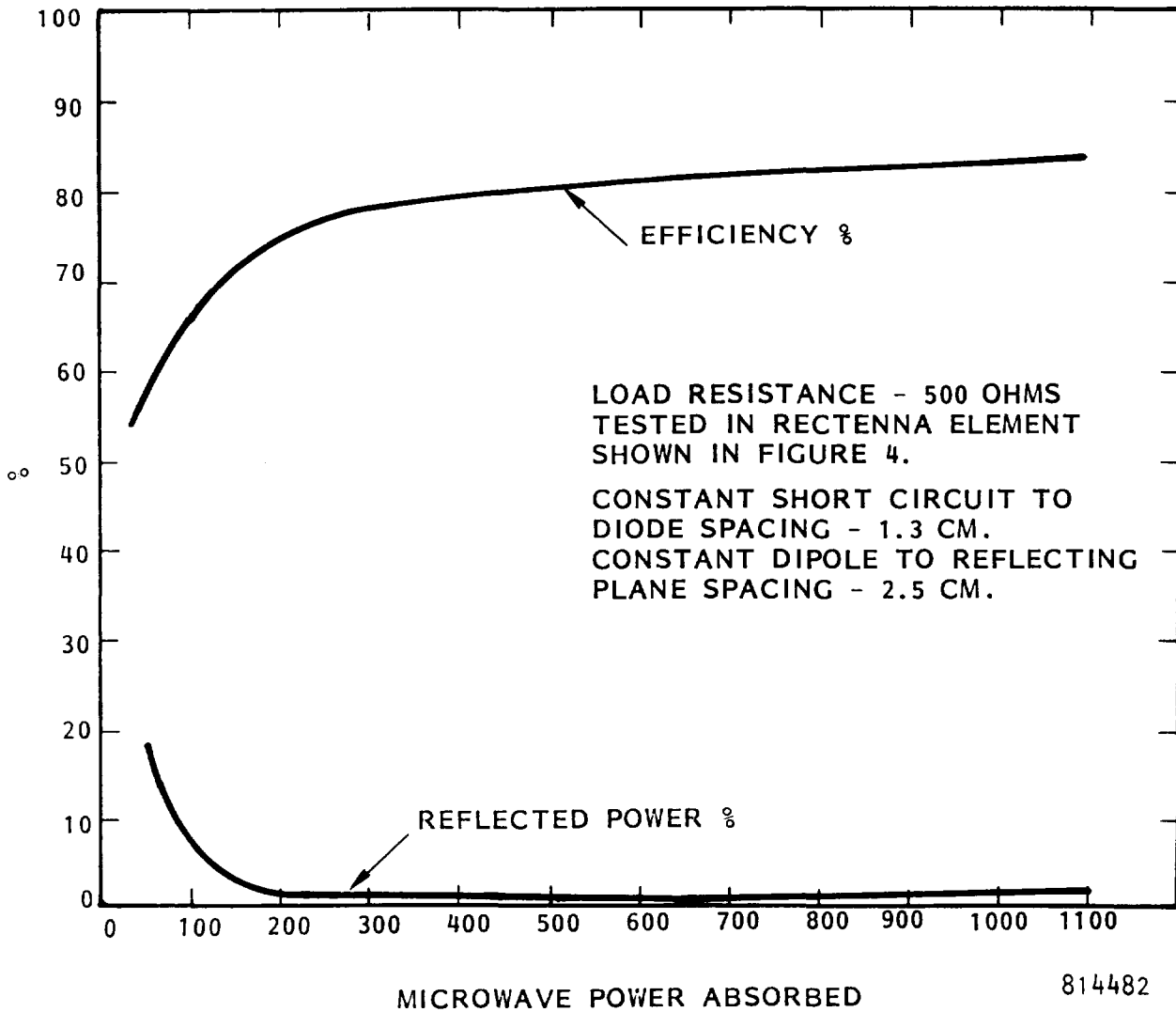

Figure 2-6. Efficiency and Reflected Power as % of Absorbed Microwave Power for the Combination of Specially Designed Microwave Diode and the Rectenna Circuit of Figure 2-5.

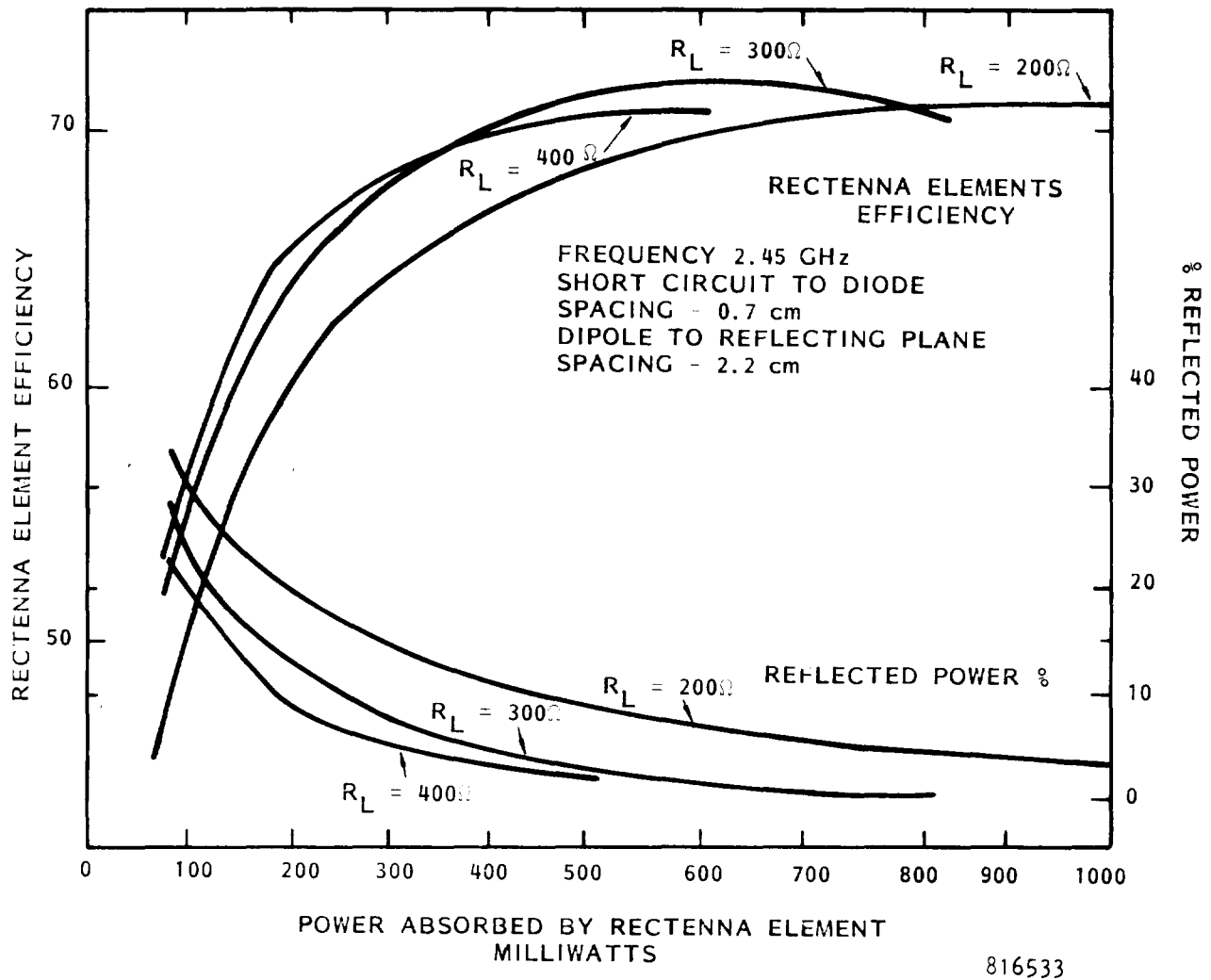

Figure 2-7. Test Results on Thin-Film Rectenna Element with Microwave Circuit of Bar-Type Rectenna Element Shown in Figure 2-5. Efficiency is Considerably Lower than that of Bar-Type Configuration.

Therefore, the first concern was with determining the source of the inefficiency, and then with correcting and improving the design, if possible.

Because the data for the bar type element and film type element were obtained using different diodes from a production lot of diodes, the first step under the new contract was to eliminate the diode as a variable by using the same diode in both the bar and film type elements. The resulting data was nearly identical, so that the diode could be eliminated as the cause.

After eliminating the diode as a potential source of inefficiency, the early effort under this contract was devoted to making measurements on the rest of the rectenna element design to determine the source of the excessive losses. These measurements involve making special test fixtures.

The first special test fixture that was made is shown in Figure 2-8, and shown again as it was inserted into the Hewlett Packard network analyzer in Figure 2-9. Basically the test fixture adapted the balanced configuration of the rectenna element to the unbalanced configuration of the coaxial connection to the network analyzer by splitting the balanced structure in half and holding one half above the ground plane which was a continuation of the outer conductor of the coaxial connection. The capacitor patches on the bottom of the element (see Figure 1-5) are clamped to the ground plane, as they should be electrically, and so adequately support the rectenna element mechanically. The characteristic impedance of the rectenna element is cut in half by this arrangement and comes close to matching the 50 ohm impedance of the network analyzer. The phase shift versus frequency properties of the rectenna element are not impacted.

The measurements of reflected power and transmitted power as a function of frequency made with this arrangement indicated poor transmission both because of resistive losses and because the cutoff frequency of the rectenna network was lower than anticipated from the electrical design. The resistive attenuation losses were greater than were anticipated from assumed properties of the dielectric material in the capacitors which was the only suspected source of loss.

To directly investigate the dielectric loss a technique for making direct measurements of capacitance and loss tangent on the capacitor used in the microwave circuit was developed. This involved the use of a holder, shown in Figure 2-10, for a sample capacitor whose area and dielectric thickness were carefully measured. Dielectric constants and dielectric losses could then be computed from the standing wave measurements made in a coaxial standing wave detector with a moveable probe. Very useful information was obtained from these measurements. Although we had expected the possibility of larger losses in the capacitor because of the unknown losses in the adhesive that was used to join the copper to the mylar, we were surprised to find: (1) the values of capacitances to be 30% greater than the design value, and (2) that the loss tangent in the mylar itself without the adhesive was .0056 or about three times that of the value of 0.002 which had been used to calculate losses in the capacitors in the low pass filters.

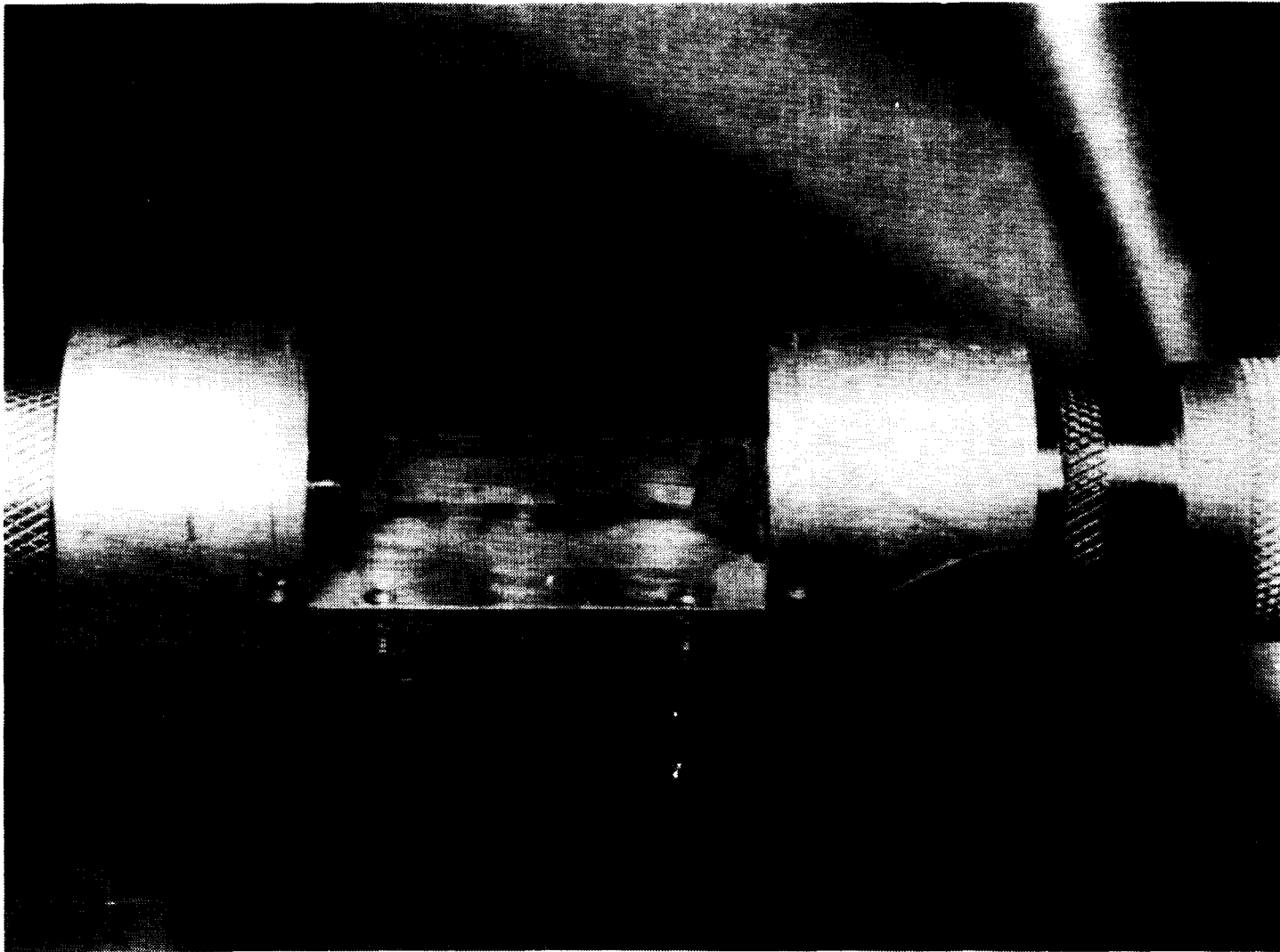

80-43768

Figure 2-8. Test Fixture for Determining Reflection and Transmission Properties of a Thin-Film Rectenna Element as a Function of Frequency.

ORIGINAL PAGE IS
OF POOR QUALITY

PT-6902

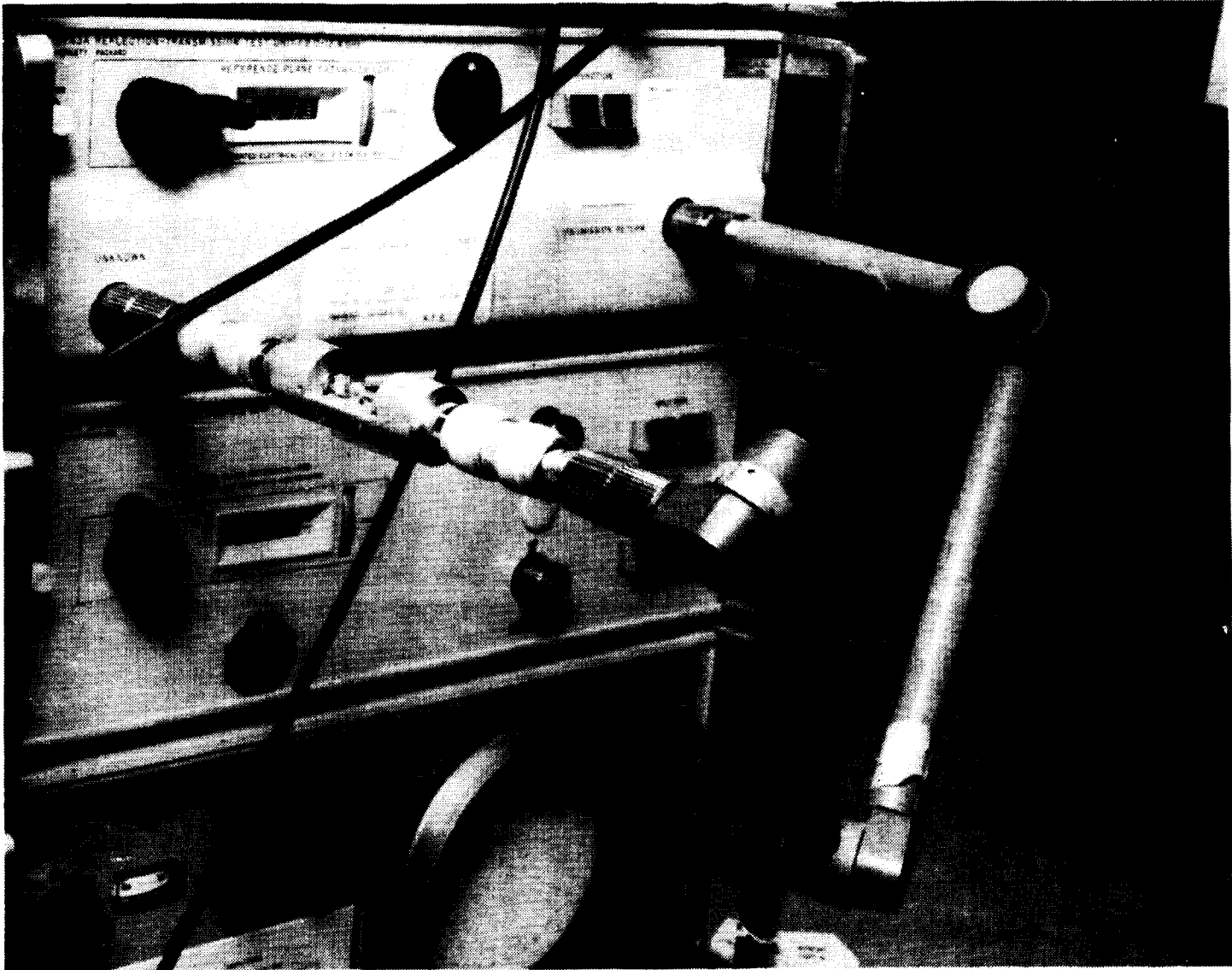
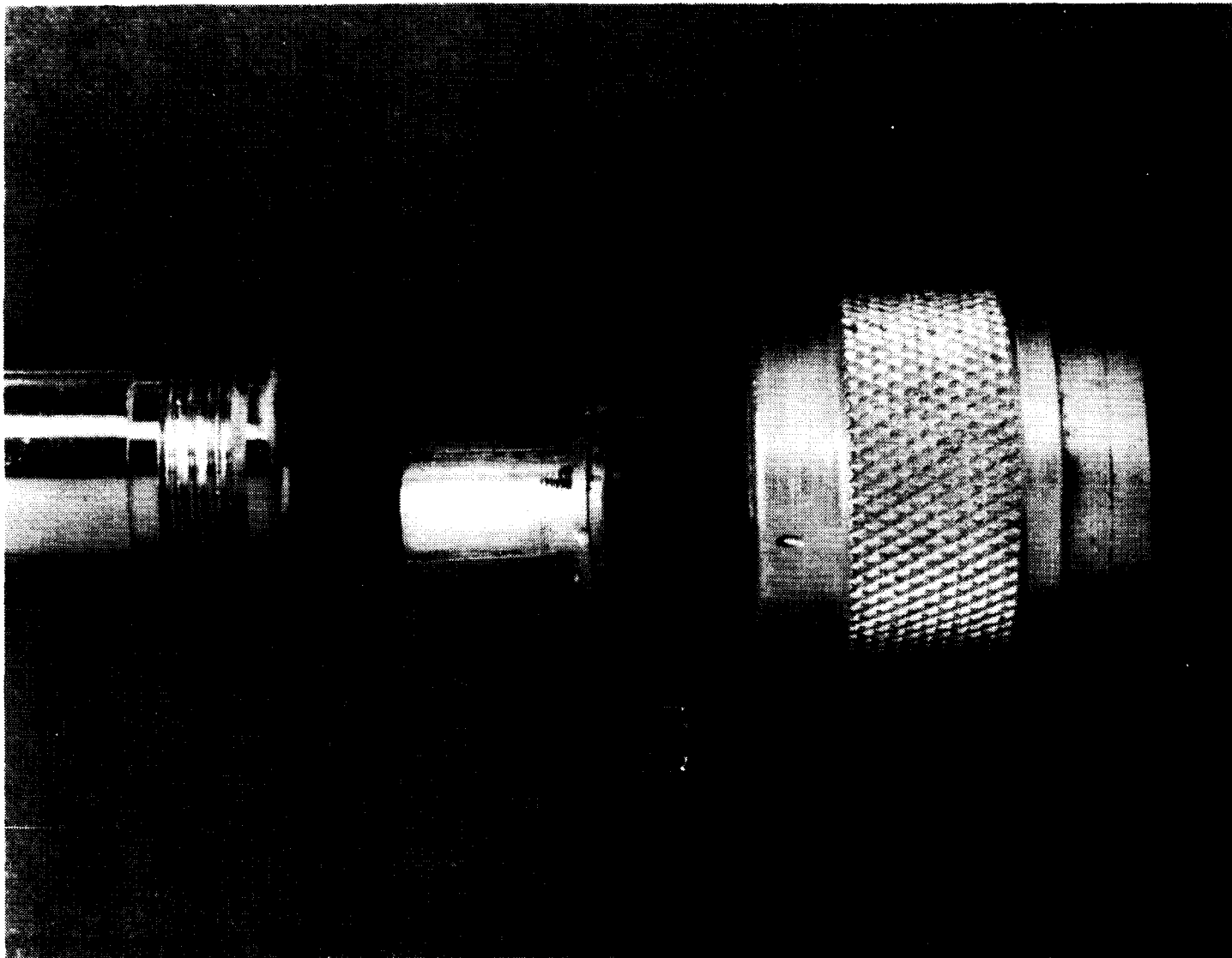

Figure 2-9. Test Fixture of Figure 2-8 Shown in Position in Hewlett Packard Network Analyzer.

80-4374B

ORIGINAL PAGE IS
OF POOR QUALITY

PT-6902



80-4373B

Figure 2-10. Special Capsule for Mounting Specimens of Capacitors Composed of Different Dielectric Materials. The Capsule Terminates a Sensitive Standing Wave Detector that could Resolve a Loss Tangent to Better than the Fourth Decimal Place, or the Difference Between 0.0026 and 0.0027, for Example.

ORIGINAL PAGE IS
OF POOR QUALITY

PI-6902

The design of the rectenna element had been based upon data on mylar taken from Figure 3-15 on page 178 from the book "Dielectric Materials and Applications", authored by Von Hippel and published by the Technical Press of John Wiley. This is considered to be the authoritative text on the subject. From this graph the dielectric constant was read to be 2.2 and the loss tangent to be 0.002 at 2.45 GHz.

The matter of conflicting data was resolved by a conversation with William Westphal of the M.I.T. Insulation Laboratory who gave me values of loss tangent and dielectric constant from mylar at 2.45 GHz that were at substantial variance with those from Figure 3-15 in "Dielectric Materials and Applications". These values are listed on page 13 of Volume 5 of "Tables of Dielectric Material", Laboratory for Insulation Research, Technical Report 119. These tables could be obtained in Xerox form but are not as generally available as the book "Dielectric Materials and Applications". The dielectric constant and loss tangent are listed as a function of frequency in Table II of this report.

It was noted from Table II that the dielectric constant at 3 GHz (which is sufficiently close to 2.45 GHz) is 2.79 rather than 2.2. Hence the capacitors that were designed under the assumption of the incorrect value of 2.2 for the dielectric constant gave capacitances that were $2.79/2.2$ or 1.268 times the design value. This mistake resulted in a lower cutoff frequency of the low pass filter than the design value, thereby introducing unwanted attenuation at 2.45 GHz.

The loss tangent for mylar at 3 GHz is given as 0.0061 in the tables. This compares with a value of approximately 0.0056 found from measurements on mylar itself.

The conclusion that can be made from this discussion is that there is good agreement between the experimentally measured values of loss tangent and dielectric constant in mylar at 2.45 GHz made at Raytheon and the data published in the tables for mylar. It follows that the data given in Figure 3-15 of "Dielectric Materials and Applications" is in error.

2.1.3 Establishment of Kapton F as a Suitable Dielectric Film Material

In the search for better film materials, Kapton coated with FEP Teflon emerged as a promising candidate. Here the real situation with respect to the published data and assumed loss in Kapton was reversed from that of Mylar. Kapton is particularly good in space with the low absorbed water content that it would have there. According to William Westphal of M.I.T., Kapton as received has a loss tangent of 0.008 at 3 GHz because of the absorbed water. However, after a bakeout at 100°C in air, the loss tangent improves to 0.0044, and after a higher temperature bakeout in vacuum the loss tangent improves to 0.0015, or four times better than mylar as we are now using it. Furthermore, Kapton will withstand a much higher operating temperature so that the operating temperature of the diode which can be as high as 200°C becomes the limiting factor in the

amount of the heat that can be radiated. The great improvement in the power handling capability of a rectenna in space made possible by changing to Kapton from Mylar is immediately evident.

Kapton, however, will not adhere tenaciously to copper cladding of the thickness that is needed and even when a thin copper film deposit is made in vacuum the subsequent addition of a thickness of electroplated copper results in an unsatisfactory product. The current technology, therefore, is to apply a thin adhesive to the Kapton before bonding copper to it, usually by compression at elevated temperatures. This adhesive is quite often Teflon. DuPont makes a commercially available product designated Type F Kapton with the Teflon already coated to the Kapton.

According to the DuPont Engineering Technical Service Type F Kapton bonds well to copper but we found there are no copper to Kapton F laminates commercially available because the bonding of the copper to the teflon requires high pressure at temperatures so high that an electrically heated press is necessary. Commercial laminates using copper bonded to Kapton use a bonding agent that will bond at the lower temperatures of steam heated presses. The low temperature bonding agents normally used are lossy at microwave frequencies.

Fortunately, we found suitable electrically heated presses within the Raytheon organization that could perform the bonding although the area of the press was limited which presented a limitation to the number of rectenna elements that could be incorporated into a single fabricated rectenna section.

The first laminates attempted with this equipment used only 0.1 mil of teflon film on the 1 mil Kapton core. The bonding was not satisfactory. The teflon thickness was increased to 0.5 mil on each face of the Kapton. These laminates were quite satisfactory and were used for subsequent work.

Measurements at 2.45 GHz were made of the loss tangent and the dielectric constant of the Kapton F material when bonded to copper. The loss tangent was established as 0.0033. This loss is considerably lower than the loss measurements of 0.0055 on Kapton alone and can be attributed to the presence of the FEP teflon which has a very low dielectric loss.

The measured value of the dielectric constant of the composite material was 3.09 or substantially higher than the computed dielectric constant of 2.63 for the composite material. This discrepancy may have been caused by improper compensation for the fringing fields surrounding the assumed one sixteenth inch diameter test capacitor or in a larger actual diameter of the capacitor than that of the mask.

2.1.4 Design of the Rectenna Element made from Kapton-F Copper Laminate

With a suitable laminate established, attention was given to the design of the rectenna element itself. There were three reiterations of the art work

that established the dimensions of the two masks that were necessary for etching the finished circuit elements on the two sides of the laminate. In addition to determining the details of the art work for the rectenna element it was necessary to make some assumptions about the spacing between rectenna elements. The assumption used was that the spacing would be the same as it was for the highly successful rectenna made from bar type rectenna elements.

The rectenna elements were spaced 7.772 cm (3.060 inches) apart in rows that were separated by 6.731 cm (2.650 inches). The 1:1 exact scale of the resulting art work for the rectenna elements is given in Figures 2-11 and 2-12. The dimensioning of the artwork may be obtained from Figure 2-13.

The electrical design of the thin-film rectenna has deviated some from that of the prototype bar-type element (Figure 2.5) in response to the difficulty of constructing mesa type diodes with zero bias capacitance, C_{t0} , as low as one picofarad and in response to the experimental observation that a diode of 3.0 pfd can be positioned across the transmission line near the point of and in place of the inboard capacitor of the second section of the low-pass filter without substantially changing the performance. The physical capacitor is eliminated but is electrically replaced by a small portion of the effective capacitance of the diode when it is in operation. The larger area of the junction in the 3.0 pfd diode increases the power handling capability of the element.

The use of a higher capacitance diode implies a lower value of resistance of the dc load, which means that the voltage drop across the Schottky barrier diode becomes a more important contributor to inefficiency unless the DC power output of the element is increased to restore the same voltage across the DC load. However, it is important to note that as time has passed it has been recognized that the rectenna element, particularly in its Kapton F format will handle much more power in a vacuum environment than had been previously thought. At the same time it was found that the anticipated space and aircraft applications for the rectenna would need a fairly high power density level of from 200 to 1000 watts per square meter, or an equivalent output of from 1 to 5 watts from each of the rectenna elements. Therefore, the higher capacitance diode is desirable for space and aircraft application but not for application as an efficient element on the periphery of the ground based rectenna in a Solar Power Satellite transmission system for which the prototype element in Figure 2-5 was developed.

The electrical parameters of the final design are shown in Figure 2-13. The values of inductance for the π section equivalents of the two sections of transmission line are given at 2.45 GHz. The values of capacitance for the π section equivalent are merged with that of the patch capacitors to provide the total capacitance value shown. The procedures for deriving these values are given in Section 3.4 of reference (1).

The design calls for the second low pass filter to serve as an impedance transformer to raise the impedance level of the microwave rectification circuit. At 2.45 GHz it is designed for 90 degrees phase shift and serves as a quarter

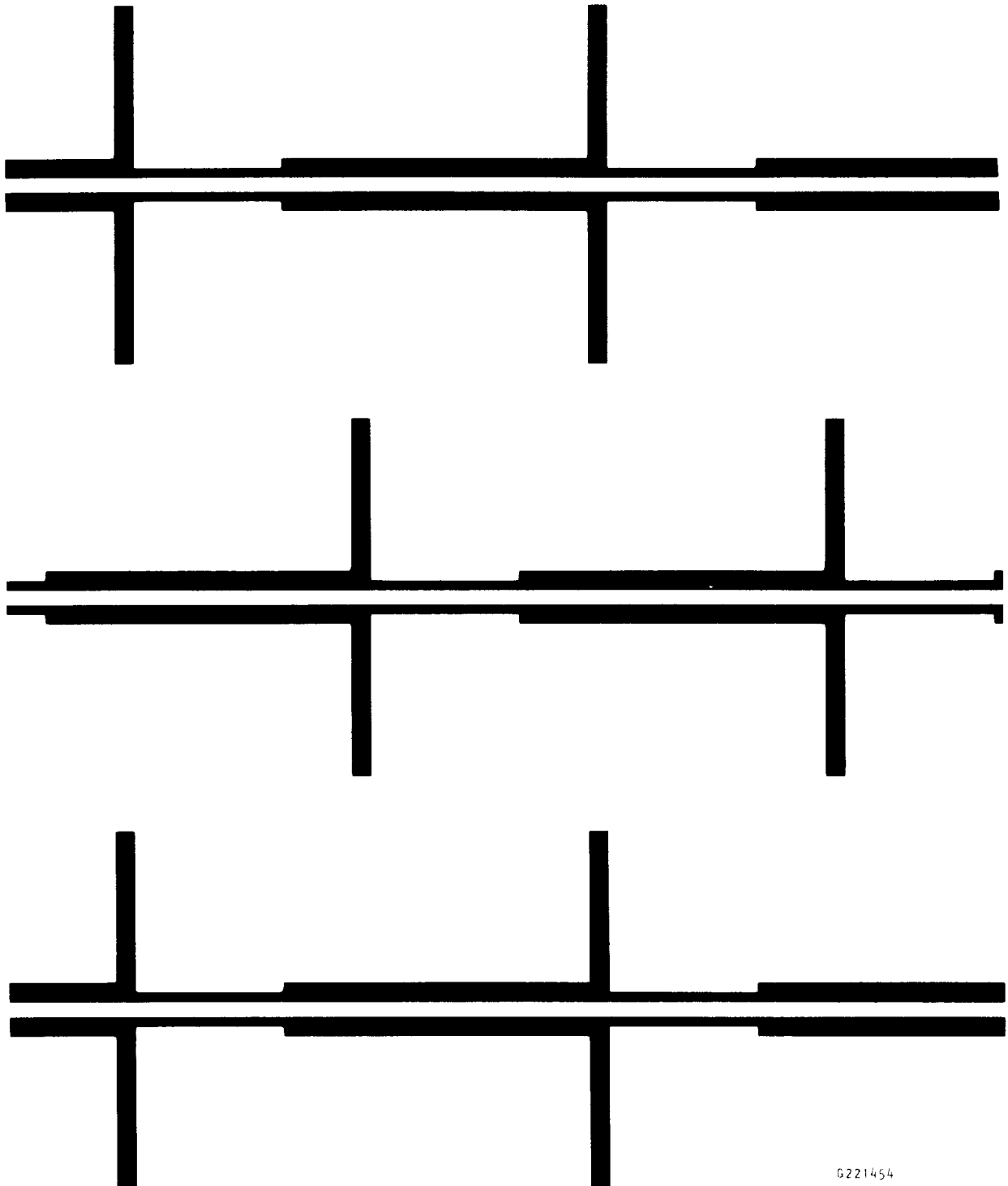

G221454

Figure 2-11. Exact Layout of Etched Circuits on Top Side of Thin-Film Rectenna. Refer to Figure 1-5.

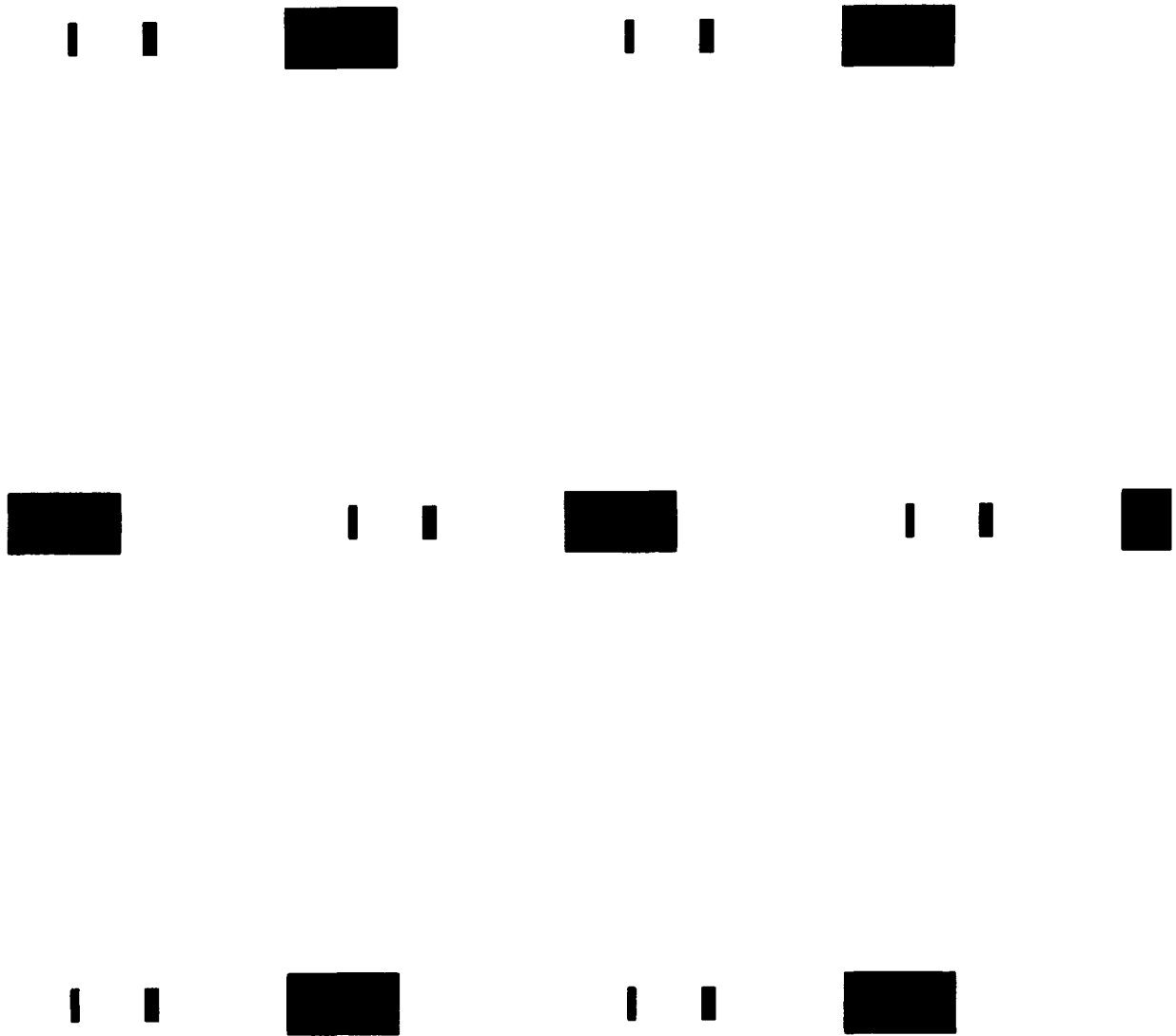

G221459

Figure 2-12. Exact Layout of Etched Circuits on Bottom Side of Thin-Film Rectenna. Refer to Figure 1-5.

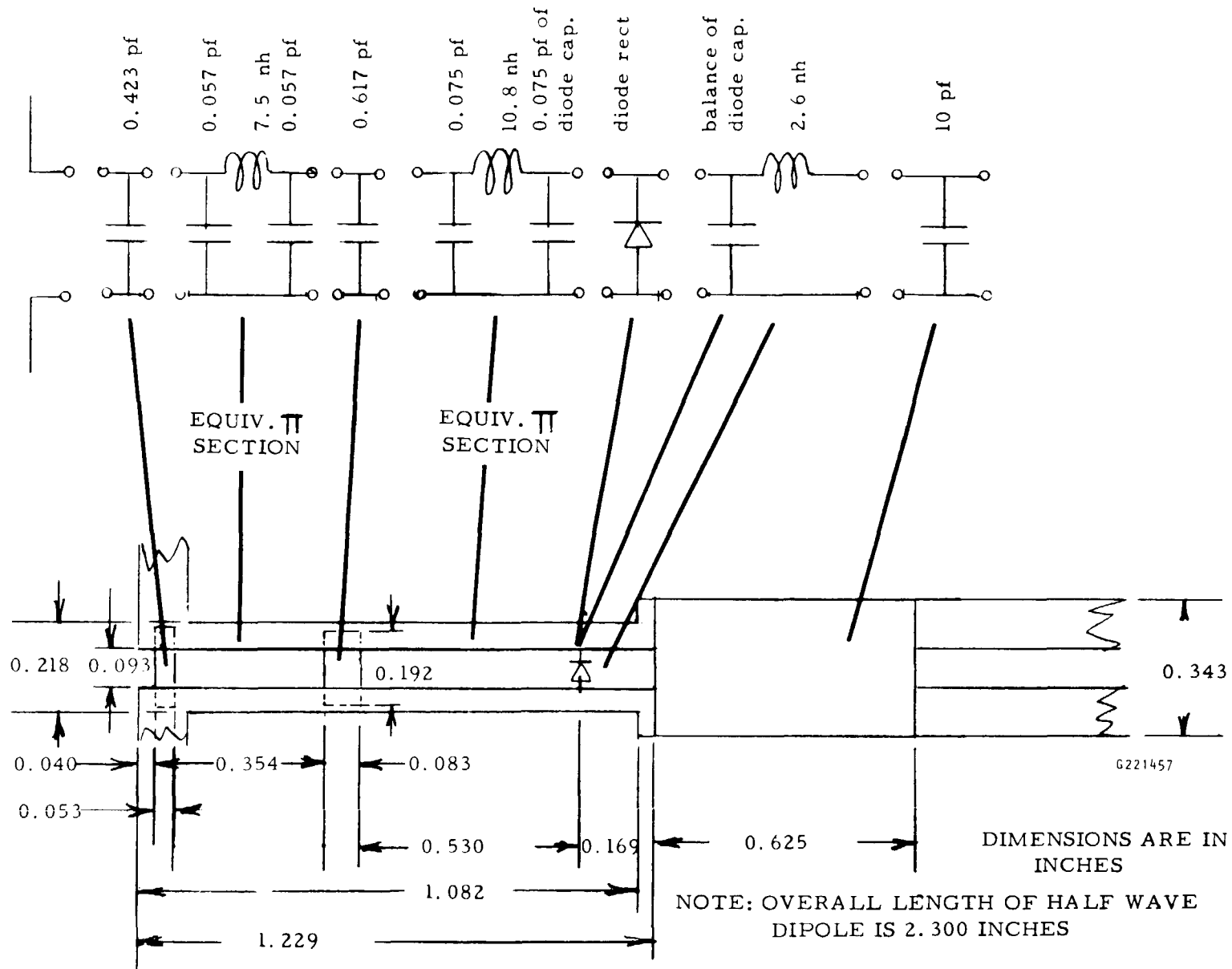

Figure 2-13. Physical and Electrical Design of Rectenna Element. At Bottom the Dimensions that Produce the Masks Shown in Figures 2-11 and 2-12 are Shown. At Top, the Electrical Schematic that Matches the Physical Design is Shown.

wavelength long line of 180 ohm characteristic impedance. The antenna terminal impedance is 120 ohms and the first low pass filter also has a characteristic impedance of 120 ohms. As seen by the rectifier circuit the impedance at 2.45 GHz looking toward the antenna is therefore 270 ohms. A reflectionless match therefore implies that the microwave impedance appearing at the rectifier circuit be 270 ohms. The DC load resistance that produces the match is typically 1.2 to 1.3 times the microwave impedance.

The data of Figure 2-14 indicates that the associated DC load resistor have a value in the range of 300 to 400 ohms to produce a good match to the rectenna. But such a value produces an excessively high peak inverse voltage for the current Schottky barrier diode when the DC power output exceeds 1.6 watts. Clearly, the rectenna element needs to be redesigned for lower impedance level when producing power levels of several watts.

2.1.5 Electrical Performance of the Rectenna Element in Its Final Configuration

Considerable data was taken on the rectenna element at each design reiteration. The data of greatest interest, however, is on the final design. The kind of data of greatest interest relates to efficiency and power handling capability. There are two different efficiencies of interest. One is the rectification efficiency of the rectenna element which is defined as the ratio of DC power output to the microwave power absorbed by the element. The power absorbed is equal to the incident microwave power minus the reflected power. The other efficiency is overall efficiency which is defined as the ratio of DC power output to the incident microwave power.

Figure 2-14 shows the overall efficiency as a function of the DC power output and the value of DC load resistance used. It also shows the reflected power as a function of DC power output and load resistance. The maximum DC power output is limited by the reverse voltage breakdown of the diode which is the sum of the DC output voltage plus the peak negative of the ac voltage waveform. This sum cannot be exceeded without a drop in efficiency. If the inefficiency is too great, the diode will be burned out. It is noted that a value of 200 ohms of load resistance has permitted a DC power output of 3.5 watts before the efficiency begins to droop. Later, in Section 2.3 when the power output of a rectenna array composed of these elements is discussed, DC power outputs in excess of 5 watts per rectenna element were obtained at even lower values of load resistance.

It will be noted from Figure 2-14 that there is considerable reflected power from the 200 ohm load. When the reflected power is subtracted from the incident power the rectification efficiency of the rectenna element is 84% at 3.5 watts and 85% at 2.5 watts of DC power output.

The rectification efficiency is probably the item of greatest interest when testing the individual rectenna element because it has been established that the collection efficiency in a properly designed rectenna can approach

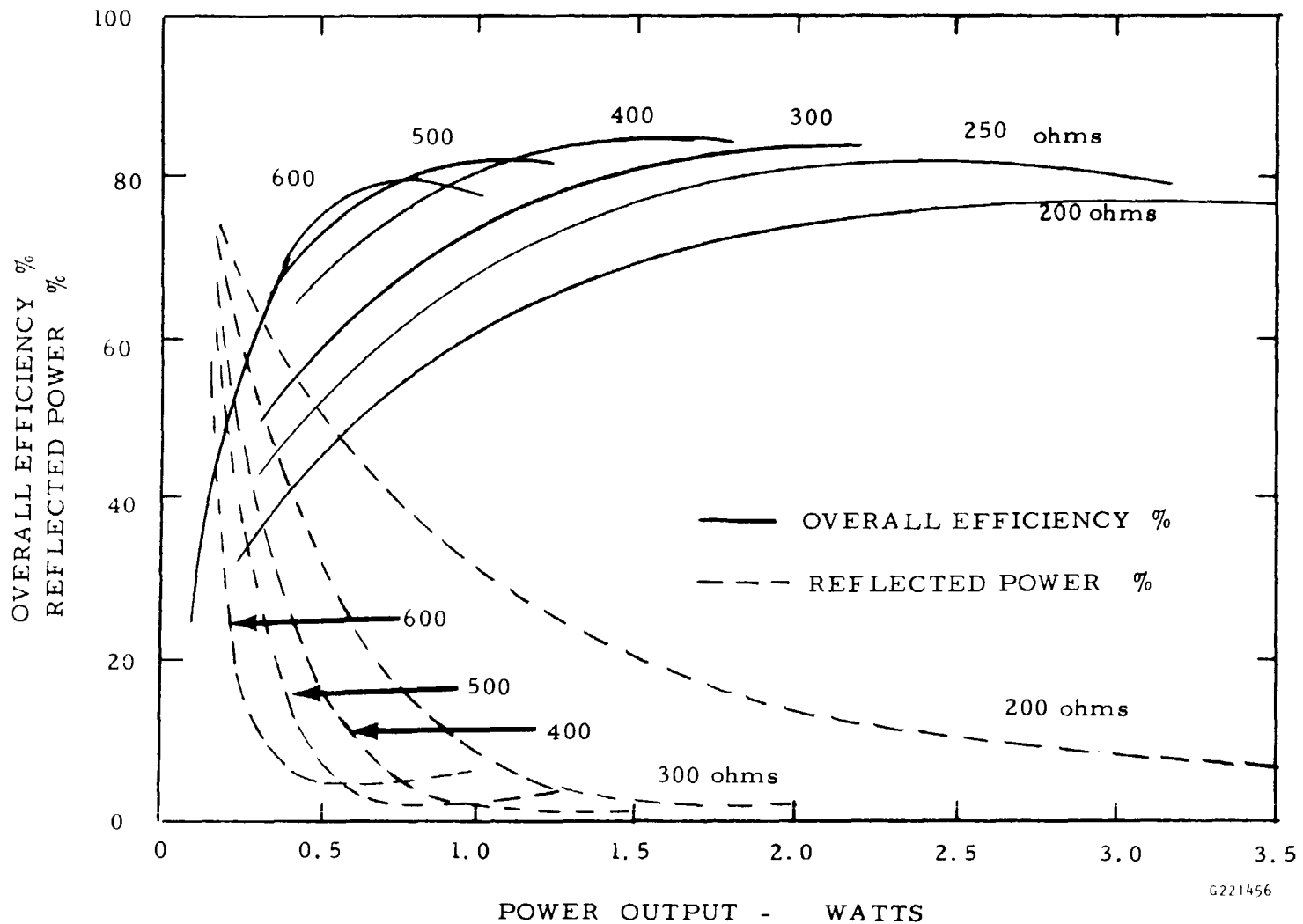

Figure 2-14. Overall Efficiency and Reflected Power Percentage are Shown as Functions of the DC Power Output and the DC Load Resistance. Power Output at Higher Values of DC Load Resistance is Limited by Start of Power Flow in Reverse Direction through the Diode. The Diode Absorbs this Power.

100%. One of the factors that must be taken into account in testing individual rectenna elements over a range of power input is that the effective capacitance of the diode is a function of operating power level so that for optimum performance the rectifier circuit should be retuned by repositioning the microwave shorting (bypass) capacitor. In a printed circuit format, however, this is not possible. The implication is that for optimum overall efficiency of the rectenna element, the operating power level must be specified.

There is considerably more test information on the power handling capability of the individual rectenna element along with that of arrays of the elements in Section 2.3.

2.1.6 Diode Development and Procurement

The Schottky barrier diode is an essential element in the rectenna. The use of GaAs as the base material is especially important in the rectenna application because of the high efficiency of diodes made from this material and because of its capability to withstand considerably higher operating temperatures than silicon. Because these diodes are not used for any other purpose, their development has always been part of the rectenna development effort.

The basic Schottky diode for the rectenna application was developed under contracts with MSFC and JPL in the 1972 and 1975 time period. However, the diode was packaged in a format not suitable for use in the thin-film printed-circuit rectenna. In the decision making process as to how the diode would be repackaged, the ultimate cost of the diode in large production volume was considered and it was decided to package it in a miniature glass package that is commonly used for mass production of all forms of diodes. This form shown in Figure 2-15 was used during the thin-film, printed-circuit, rectenna development for Wallops Flight Facility and during the early phases of the current LeRC activity. It worked out well and it was intended to use this for the entire LeRC activity. However, during a move of the Special Microwave Devices Operation from Waltham to Northborough the tools were lost to make these diodes. Because of the cost of replacing these tools, it was decided to repackage the diode in a ceramic pill package of the format shown in Figure 2-15. At the same time it was decided to increase to zero bias capacitance of the diodes to reduce the scrap involved in making the mesa type diodes.

The impact of this design change in packaging and the increase in capacitance upon the design of the rectenna element was considerable. For the rectenna element to perform satisfactorily it was found necessary to eliminate the inboard capacitor and reposition the diode as shown in Figure 2-13. In the final format shown in Figure 2-13 the performance actually appeared to be better than for the glass diode.

The new diode is considerably better from the heat dissipation point of view than is the glass diode because there is little resistance to heat flow

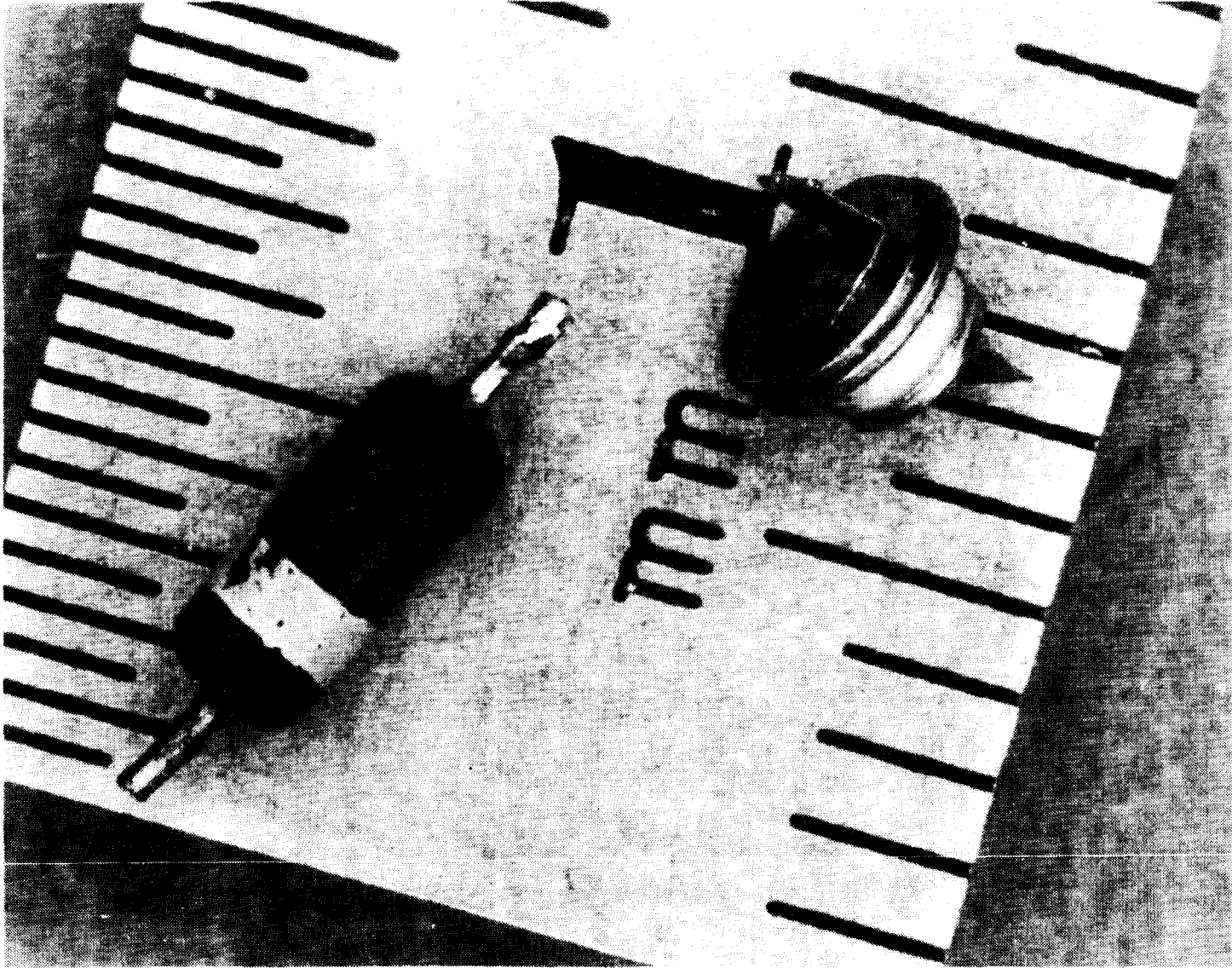

Figure 2-15. The Diode for the Thin-Film Etched-Circuit Rectenna was Packaged in Two Formats Shown Above. One was the Miniature Glass Package While the Other was the Miniature Ceramic Pill Package. The Glass Package was Used for the Early Development of the Thin-Film Rectenna. The Ceramic Package is Currently being Used.

81 24738

ORIGINAL PAGE IS
OF POOR QUALITY

PT-6902

from the diode to the transmission line upon which the diode depends for the conduction and radiation of heat. In the glass diode there is considerable resistance because of the dumet lead which is a relatively poor heat conductor. It is also of interest that the heat flows out of the ceramic package in both direction in about equal amounts because of the excellent heat conduction properties of the alumina ceramic shell.

The diode specifications that were used for the procurement of the diodes is as follows:

- Semiconductor material - type n GaAs.
- Plated heat sink for good conduction of heat away from junction.
- Metal used at junction - platinum.
- C_{t0} (zero bias capacitance) - 3 pf \pm 10%.
- V_b (reverse voltage breakdown) - 60 - 70 volts.
- Reverse Leakage - 10 microamperes at 80% of breakdown voltage.
- Slope of voltage current characteristic - 1.5 ohms maximum at 100 milliamperes of DC current.
- To be packaged in Raytheon ceramic package #3000119.
- 0.040 inch wide ribbons to be attached to both covers of ceramic package.

The electrical portion of these specifications is considerably relaxed from that used for comparable diodes for the large rectenna array designed and manufactured for a microwave power demonstration on the Mojave desert in 1975. The motivation was reduced cost achieved by eliminating rigorous quality control procedures. However, for any procurement where high reliability is needed it is recommended that a more restrictive specification be used.

In particular, it is essential to specify the voltage drop across the entire diode at very low current conduction in the forward direction, because the slope of the voltage current characteristic at 100 milliamperes does not necessarily guarantee a low voltage drop across the diode. For example, another Schottky barrier can be used in place of a low resistance ohmic contact. While this will automatically double the voltage drop across the diode at low currents and drastically reduce the efficiency of the diode it will not greatly impact the slope of the voltage-current characteristic at high currents.

2.1.7 Summary of Activity on Task 1

- The causes of low efficiency in the thin-film, etched-circuit rectenna element were found and identified as unexpectedly high loss in the mylar and expected losses in adhesive.
- In a search for better film materials Kapton Type F was found and projected to result in a much superior rectenna element in terms of efficiency and ability to operate at high temperatures.
- Three reiterations of the rectenna element design were made before finalizing the printed circuit masks in the third reiteration.
- Substantial changes were made in the Schottky barrier diode design. The package was changed from glass to ceramic; the area of the junction was increased three fold to improve diode yield and to be more in accord with the trend towards operation of rectenna elements at higher power levels for space and high altitude air vehicle applications.
- Electrical tests were made on the final design of rectenna element over a wide range of microwave power input and DC load resistance. Efficiency and reflected power were noted. An overall efficiency of 85% at 1.5 watts DC/output was obtained and a rectification efficiency of 84% was obtained at 3.5 watts of output. Limitation in power output and efficiency was the reverse voltage breakdown of diode.

2.2 Design of a Complete Rectenna Array (Task 2)

2.2.1 Introduction

One of the attractive features of the rectenna for space use is the assumed relative ease with which it may be deployed. For example, in the scenario assumed in Reference 8 all the rectenna that would be necessary for a 50,000 square meter array in space, enough to conservatively generate at least 10,000 kilowatts for an electric powered interorbital vehicle like that shown in Figure 2-16, could be carried into low earth orbit in one shuttle payload.

The rectenna would be carried into space in rolls that are 18 meters long to fit within the shuttle payload bay. Each roll would contain a rectenna that is 200 meters in length wound on a spool that is 30 cm (1 foot) in diameter. The outside diameter of the spool would be 71 cm (2.33 feet). These dimensions allow for a spacing of 0.165 cm (0.065 inch) between turns which accommodates a special construction that allows the rectenna, consisting of a foreplane and reflecting plane, to collapse when it is wound on the spool. Since each of the rolls is 18 meters long, the number of rolls needed to comprise the 50,000 square meter rectenna area is 14. The rolls could therefore be stored within a cross sectional area of 7 square meters or in about 35% of the 20 square meter cross section of the cargo bay. The estimated mass of the complete rectenna is 10,000 kilograms, and a more conservative figure of 15,000 kilograms would require about one half the payload mass of the shuttle.

The foregoing example of deployment in space represents a good starting point for a more general discussion of deployment, and in introducing a general problem in deploying the rectenna. The general problem of deploying the rectenna is that to capture energy efficiently the rectenna must be a two plane structure. Behind the thin-film etched-circuit foreplane there must be a reflecting plane about 0.2 wavelengths or 2.5 cm behind the foreplane. The foregoing example assumes that this distance is collapsed down to 0.165 cm, a ratio of 15.

Alternative means of deployment that come to mind are (1) taking the rectenna up in panel form, (2) deploying the foreplane from one roll and the reflecting plane from another roll, (3) deploying both from the same roll. The first alternative has many objections, including the necessity of very large storage space in the shuttle, increased mass, and high cost. The second alternative resolves the need to collapse the thickness of the rectenna but leaves unresolved the need to maintain the spacing of the reflecting plane from the rectenna foreplane. Both of these options do not seem very attractive.

2.2.2 An Approach to a Collapsible Rectenna

The example of deployment of a collapsed rectenna from a single roll also illustrates that the collapse does not have to be that complete. A complete collapse of the rectenna foreplane and the reflecting plane without the consideration of the diode would be only 3 mils. The eventual diode

MICROWAVE POWERED OTV

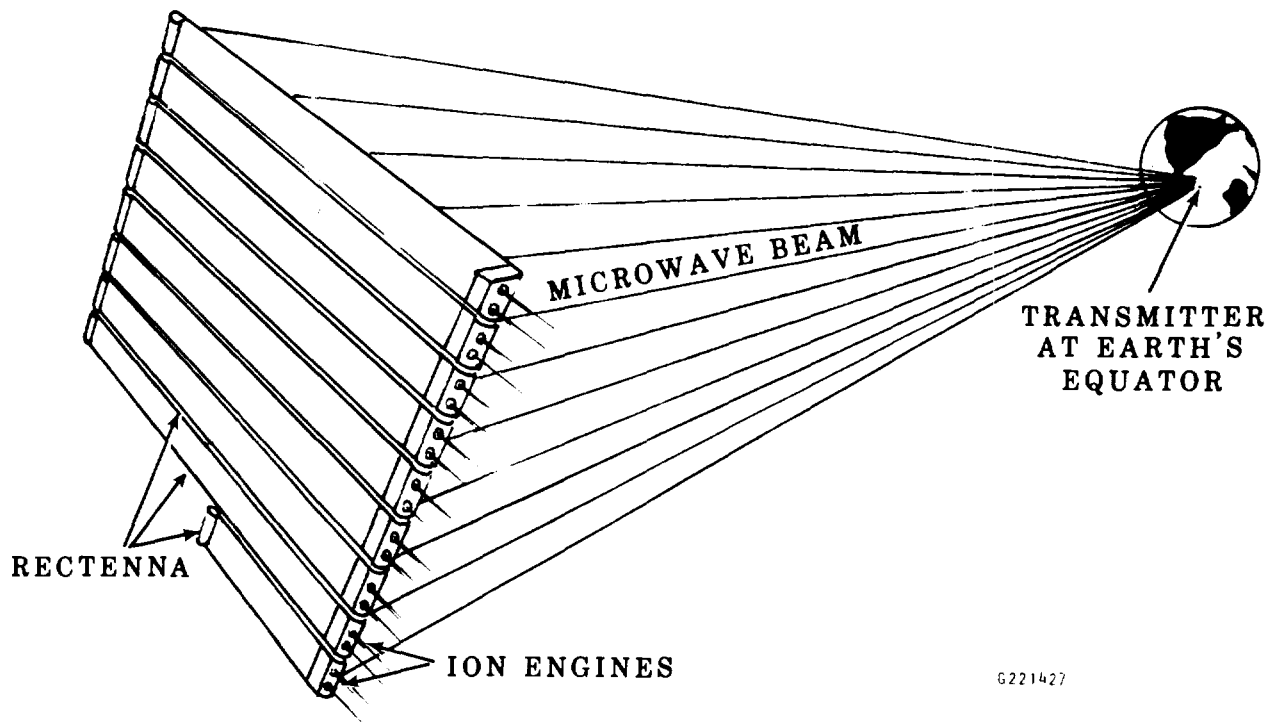

Figure 2-16. Concept of a Microwave-Beam Powered Transportation Mode from Low-Earth to Geosynchronous Orbit. Microwave Power is Beamed from a Ground Station to the Vehicle which has a Large Rectenna to Absorb the Microwave Power and Convert it into DC Power to Energize the Electrical Propulsion Engines. The Vehicle is Transported in Modular Form within the Cargo Bay of the Shuttle and Assembled in Low-Earth Orbit. Each Module Contains Ion Engines Together with Their Supporting Rectenna Sections which are Stowed in Rolled Up Form During Transportation in the Shuttle.

developed for this application should not exceed ten mils in thickness; so that a collapse to 20 mils in thickness should eventually be possible.

However, the present height of the diode is 60 mils. It may be useful to use this as a starting point and assume that the resulting collapsed thickness would be 0.065 inch. This distance of 0.065" then permits about 0.062 inch for the collapse of some kind of compression spring.

In the stowed position, the spring is collapsed but in the deployed condition the spring is still under some compression and its extended length is constrained by a string attached to the foreplane and reflecting plane. The length of the string, fully extended, represents the desired distance between the foreplane and the reflecting plane.

Although the use of a metal spring may be considered, a moment's reflection would suggest that there are potential complications and that a plastic spring might therefore be preferable. Although plastics as a spring material are greatly inferior to metal, the application under discussion does not demand repeating flexing; nor does the spring in its extended position need to exert much force.

In making a search for the best plastic material, it might be well to start with Kapton itself to see how it might be used. Kapton is already being used in the rectenna. It also has some interesting mechanical properties. It has a combination of a yield point and a modulus of elasticity that allows it to be wrapped around a mandrel of small diameter in relationship to the thickness of the Kapton before the Kapton takes a permanent set. Or, expressed another way, the ratio of the radius of curvature to the thickness of the material before it takes a permanent set is relatively low. Low enough to suggest that rolled up circular loops of Kapton film two to six mils thick may be flattened to 60 mils; and then spring out to their original diameter, or near it, when the compression is released.

An experimental program to investigate this was undertaken. Kapton of different thicknesses was obtained, rolled up into loops, the ends of the loops sealed together with scotch tape. These loops were then compressed between two flat metal plates. One of the plates had two side rails of 0.062" thick material to limit the amount of loop compression to that assumed that it would undergo when being wrapped up in a roll. With this amount of compression it was found that three mil Kapton took no set at all, while 5 mil Kapton took a small amount of set.

After the loops were so compressed, they were mounted between two plates, the top plate being very light in weight and free to move with respect to the bottom plate. Weights were added to the top plate and force-deflection data taken on the loops. From these force-deflection curves, it was noted at what force the height of the loop was 2.5 cm, the expected distance between the

foreplane and reflecting plane of the rectenna. Representative data obtained from this experimental procedure is given in the following table.

Compression characteristics of circular loops of Kapton.

Diameter of Loop (cm)	Thickness of Kapton (mils)	Force Required to Compress Loop to the Normal Separation Distance of 2.5 cm Between Foreplane and Reflecting Plane (Grams per cm Loops Width)
4.13 (1.625 inch)	5	6.2 grams
4.13 (1.625 inch)	3	1.0 grams
5.08 (2.0 inch)	5	5.3 grams

From this data it is noted that a loop one centimeter wide made from 5 mil Kapton exerts a force of five or six grams between the two planes at a separation distance of 2.5 cm. In a "gravity free" space environment, it is assumed that this is enough force to always keep the constraining strings taut. How many of these would be needed per unit area would have to be determined eventually by some experimental work performed in a gravity free environment.

Figure 2-17 shows how such loops of Kapton could be applied to the foreplane of the rectenna. Each of the loops would have a length of string inside it that corresponded to the desired separation distance between foreplane and the reflecting plane.

2.2.3 Considerations Involved in Spooling the Collapsed Rectenna

From the past discussion it appears that there is a straight forward method of maintaining the separation distance between the reflecting plane and the foreplane that still permits compressing the rectenna to a thickness of 0.165 cm (0.065 inch). However, it must be recognized that when the rectenna is rolled up there will be a difference in the circumference of the two surfaces equal to 6.28 times the separation distance between the two planes. This distance is accumulative over the entire length and could amount to several meters.

There are two potential solutions to this problem. One solution is to roll the reflecting and foreplanes together but leave the reflecting plane unattached. In this case some force must be found to press the reflecting plane against the supports extending from the foreplane. One mechanically simple way is to use electrostatic attraction between the two films that could be established by a voltage applied between the two surfaces. A potential of 1000 volts would provide an attractive force of several grams per square meter, enough to hold the reflecting plane to the foreplane supports.

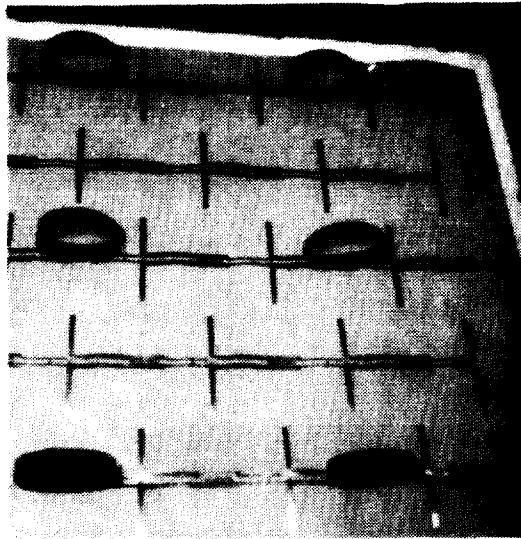

G221441

Figure 2-17. Photograph of Rectenna Foreplane with Loops of Kapton Attached to Separate Foreplane from Reflecting Plane. Loops are Compressed During Roll-Up on Spool, but Return to Original Shape when Compression is Released. A string in Center of Each Loop Limits Height to Separation Distance Needed between Foreplane and Reflecting Plane.

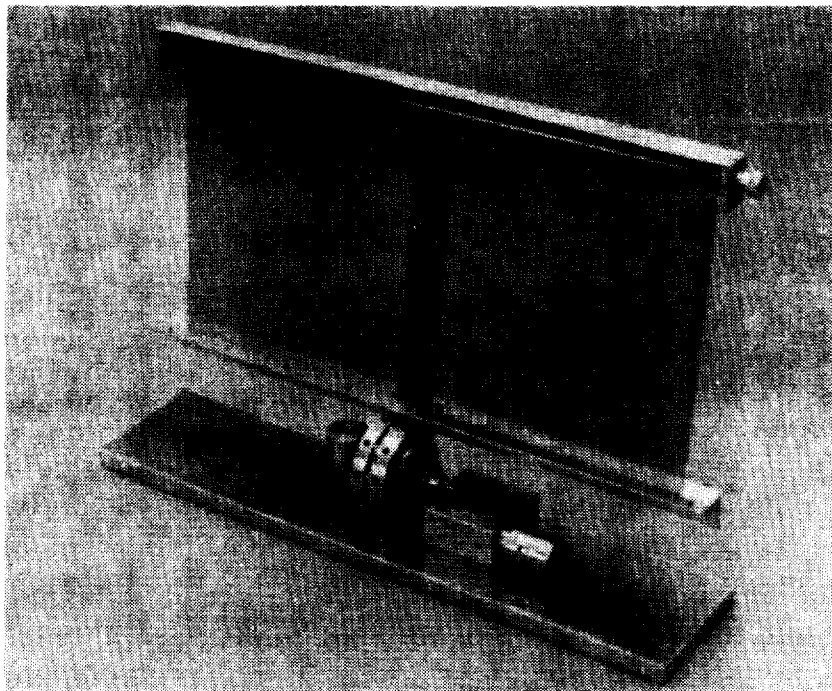

G221442

Figure 2-18. Model Showing Deployment of "Rectenna" from Rolled Up to Extended Form by Means of a Support Member which can also be Rolled Up but which becomes Rigid when Unrolled. Model Used a Carpenter's Rule to Illustrate the Principle.

A second approach would be to attach the planes to each other but to wind up the rectenna while retaining some slack in the reflecting plane in the rolled up condition. Still another alternative is to put the reflecting plane toward the outside and deliberately apply some tension to it while it is being rolled up. The reflecting film is the film that should be manipulated because it will have a small fraction of the mass and strength of the foreplane.

Related Considerations Involving Support of Rectenna in Space When Unrolled

The selection of a construction format for the two plane rectenna depends not only upon how it is stowed before deployment but also upon how it is deployed. In general, there would be two kinds of deployment. The first would be to unroll it onto some kind of a supporting structure. The second would be to have the rectenna combined with some mechanical boom that would also roll up into a cylinder immediately adjacent to the rectenna. At this time it is too early to determine which is the preferred method, and the method used may well depend upon the space application.

The second mode of deployment is that portrayed in Figure 2-16 and in a photograph of a model of such deployment (Figure 2-18). The model uses a thin, curved, metal strip that is rigid when extended but that can be rolled up to conserve space. It is, in fact, a commercially available 6 foot carpenter's rule. In space, of course, with no steady state forces acting on the boom, such a boom might be 100 meters or more in length. It should be possible by means of tethers to slightly bow the boom so that the reflecting plane would be on a convex surface. In that case, the reflecting plane could be kept in contact with the separators by a slight tensile force exerted at the two ends of the reflecting plane.

The first mode of deployment might very well be used in connection with a much larger structure that would either be a permanent low earth orbit around the equator, or that could be used as a heavy transport vehicle for orbital transfer. Such a structure if it were used for manufacturing might receive all of the electrical power it needed from transmitters located at the equator on the surface of the earth. Or if used for interorbital transport, such a large aperture would make it efficient and useful well beyond geosynchronous orbit, perhaps even to the moon. Such a platform would no doubt have some kind of rigid support truss. This would make for easy deployment of the rectenna and forming it into a slightly convex surface to permit stretching of the reflecting plane over the rectenna.

2.3 Fabrication and Testing of a Large Area Sample Rectenna (Task 3)

2.3.1 Introduction

In several respects, the fabrication and testing of a large area sample rectenna was the principle objective and task of the first activity covered in this final report. The objective is to assemble rectenna elements of an identical optimized design, into a very light weight (low mass) rectenna foreplane of considerable area that can be easily fabricated and that will operate at high efficiency and at relatively high power density levels with long life and high reliability.

Although a 14 element foreplane had been fabricated from a design based on the use of mylar as the thin film material under the Wallops Flight Center study only individual elements had been tested, and these had been found to be inefficient, as reported in Section 2.1.

During this new study we were able to first fabricate and test a 14 element foreplane made from a much improved sandwich material using Kapton-F film and employing diodes having improved power handling capability. No measurements of diode temperature or velocity of cooling air were made in these tests.

Then new masks were made for a larger rectenna area consisting of six rows of five elements each, or a total of 30 elements. For test purposes only, five rows of rectenna elements were used as shown in Figure 2-19.

The test set up for this 25 element rectenna was instrumented to make measurements of the velocity of the cooling air flowing over the surface and of the operating temperature of the diode case of the central rectenna element. A DC output of 120 watts from this 25 element section was achieved with a temperature rise of only 50°C with an air flow velocity of 4.8 m/sec., 15.8 ft./sec., or 10.8 Mi/hr.

The setup for testing the 25 element section was then used to test a single rectenna element. First, without microwaves being involved, measurements were made of the temperature rise of the diode as a joint function of (1) DC power injected into and dissipated within the diode and of (2) the velocity of the cooling air flowing over the rectenna. Then, with a known velocity of air flowing over the element, the microwave power beam was directed at the rectenna element and measurements of DC power output and diode temperature noted. From the use of tabulated data in the previous run which related diode dissipation to diode temperature, the rectification efficiency of the rectenna element could be approximated closely from the expression

$$\text{rectification efficiency} = \frac{\text{DC power output}}{\text{DC power output plus diode dissipation}} \quad (1)$$

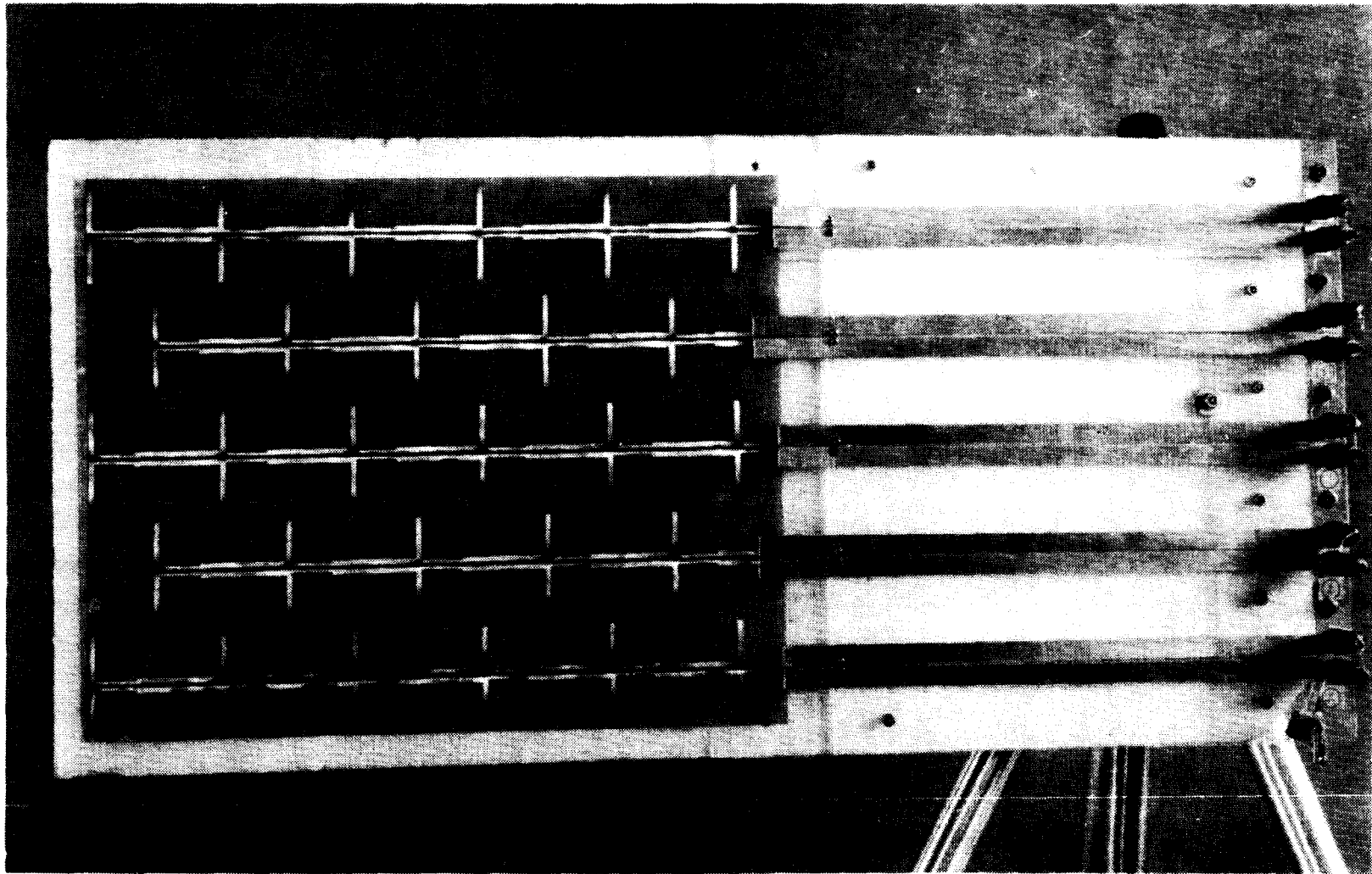

Figure 2-19. Rectenna Array with 25 Active Elements Set Up for Test in Microwave Beam as Shown in Figure 2-20. Foreplane is Separated from Metallic Reflecting Plane by 1.8 cm of Styrofoam. Three of the Five Inboard Elements on the Rectenna are Not Active.

86-0452C

PT-6902

ORIGINAL PAGE IS
OF POOR QUALITY

These efficiencies were consistently over 80%. Power output as high as 6 watts for the element was also obtained. Maximum power output was limited not by the diode temperature but by the value of reverse voltage breakdown of the diode and by the high characteristic impedance of the rectenna element structure. With a proper redesign of the diode and the balance of the rectenna element, twenty watts per rectenna element could be achieved without exceeding either the allowable operating temperature of the diode or the velocity of air flow used in these tests.

In defense of this procedure for measuring the rectification efficiency of a single rectenna element, it is noted that the edge effects are not well known and would introduce a large uncertainty into an efficiency calculated on the basis of measuring the incident power density of the beam.

2.3.2 Test Arrangement and Test Results on 25 Element Rectenna Foreplane with Forced Convective Cooling

This section discusses test results on power handling capability and efficiency of the rectenna foreplane when subjected to low-velocity convective air cooling at sea level air densities. These conditions are equivalent to cooling obtained at typical airplane flight speeds and air densities at altitudes of 40,000 feet and more.

The tests were made with the test configuration shown in Figure 2-20. The velocity of the air stream flowing across the rectenna was calibrated with a hot wire anemometer. The temperature of the diode was monitored during operation with a probe of a fluoroptic thermometer that was mounted at the diode case with precaution to shield the probe from the air stream. The great advantage of the fluoroptic thermometer is that it does not interact with the microwave field and does not conduct heat away from the source it is measuring.

In preparation for testing, the 25 element rectenna section was mounted on a test board as shown in Figure 2-19. The DC outputs of the five rows of rectenna elements were connected in parallel across a single load resistor. Each row had a zener diode shunted across it to protect the diodes in the row should the DC output voltage for any reason exceed a value that would cause the peak inverse voltage across the diodes to exceed their reverse breakdown voltage rating. An open circuit concurrent with large values of incident microwave power would be the type of fault for which the zener diodes would provide protection.

A current jack in the output of each row made it possible to monitor the operating current and power output of each row.

The array shown in Figures 2-19 was then inserted into the test arrangement depicted in Figure 2-20. So as not to exceed the reverse voltage breakdown of the diodes at high incident power, the common load resistance used was 4.7 ohms. If the 4.7 ohm resistance was equally divided among the 25

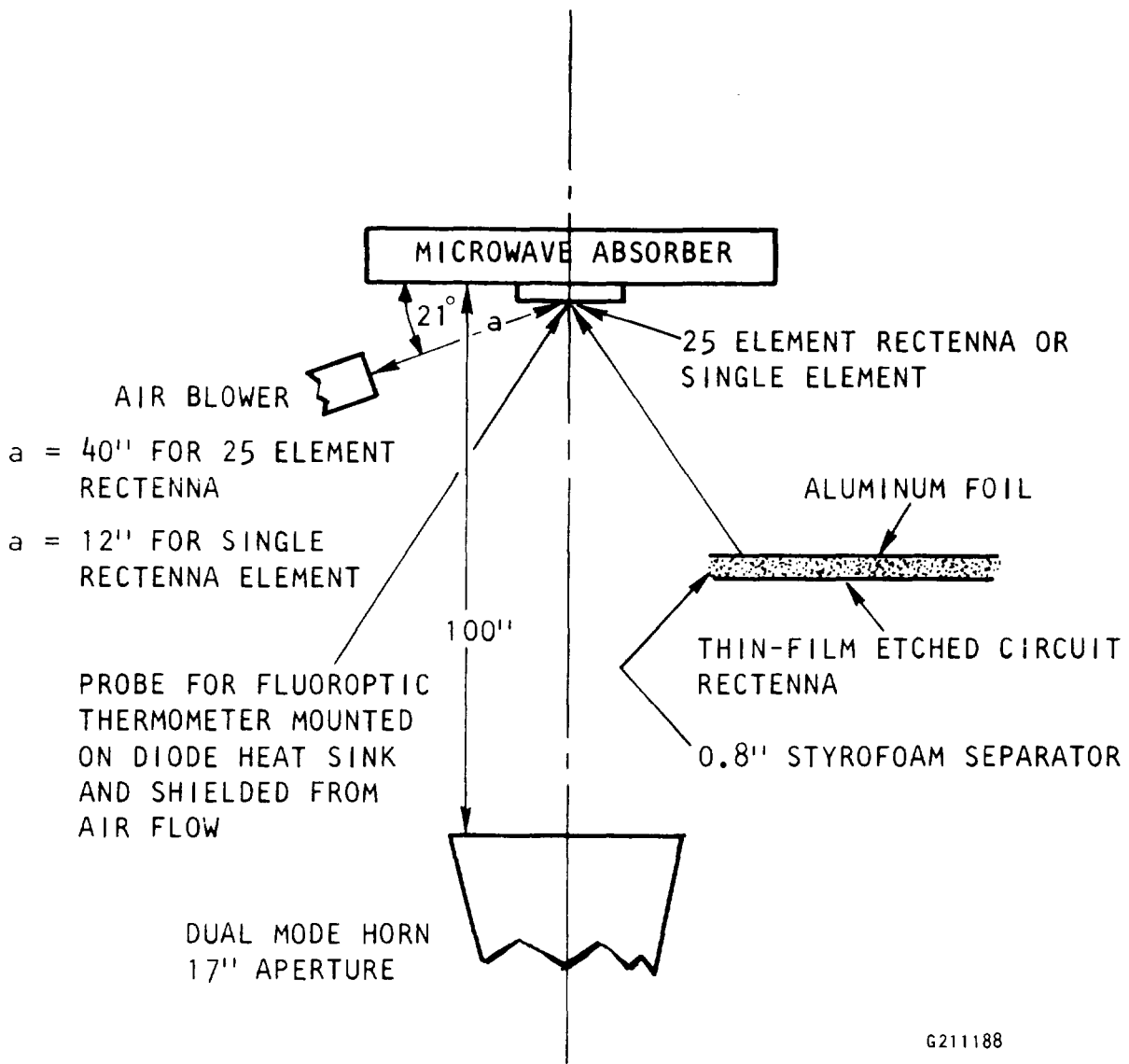

Figure 2-20. Test Arrangement for Measuring DC Power Output and Diode Temperature Rise of 25 Element or Single Element Rectenna as Function of Laminar Air Flow Velocity and Incident Microwave Power Level.

elements, each element would see a value of 118 ohms. The air flow velocity was 4.8 meters/second. The temperature of the case of the diode of the central rectenna element was monitored. For the test, the microwave power output of the illuminating dual-mode horn was varied and the DC power output of the rectenna and the temperature of the diode case were monitored.

The results of this test are shown in Figure 2-21. The maximum total power output of 123 watts corresponds to an average of 4.9 watts for each of the individual diodes. The unequal illumination of the diodes as well as the tendency of the top and bottom rows to capture more power than the internal rows means that some of the rectenna elements were producing more than 6 watts of DC power output. The highest diode temperature of 88°C is far below the 200°C operating temperature considered safe for GaAs diode operation. The temperature rise in the diode was approximately 48°C. The high temperature of 39.5°C for the diode with no incident microwave power was caused by heat stored in the microwave absorber that was placed behind the rectenna and that had absorbed energy over a period of time prior to making the run recorded in Figure 2-21. The room ambient temperature in regions removed from the absorber was 31°C.

The observation of such high DC power outputs with only relatively low air flow velocity and with such low temperature rise in the diode was an exciting experimental finding that had not been expected. It is an especially important finding for many of the applications of microwave power transmission in both aircraft and space.

The normal procedure, with the data of Figure 2-21 in hand, would be to operate the rectenna at even higher power densities, but unfortunately, the reverse voltage breakdown of the diode and the relatively high impedance design of the rectenna element precluded higher power operation. However, as indicated in the introduction it is possible to extend the data for temperature rise in the diode as a function of power dissipation within the diode and air flow velocity to provide an accurate indication of the DC power output capability of the rectenna element, if an efficiency for the element is also assumed, as will be discussed in Section 2.1.3.

A finding of considerable importance was made in testing the rectenna. It was found necessary to put all the rows in parallel. If they were put in series there was an unstable load sharing situation in which some rows capture a large amount of power while others capture very little and put out very little DC power. When the rows are in parallel there is good load sharing particularly at the higher power levels where presumably each individual element is better matched into space.

It would also be expected that the two rows of elements at the edge of the array would pick up more power than the center rows and this was found to

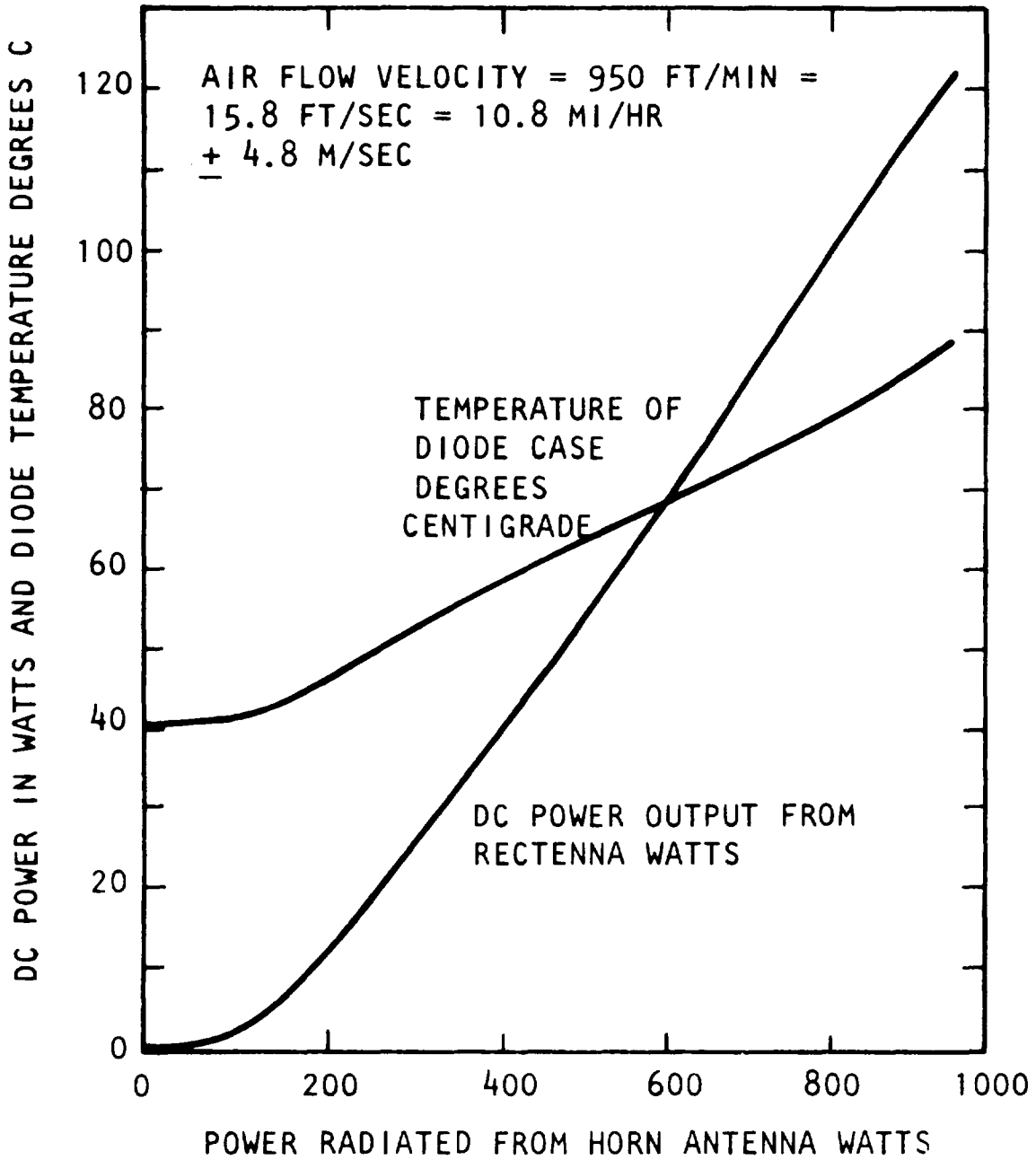

G211191

Figure 2-21. DC Power Output of 25 Element Rectenna and Case Temperature of Diode of Center Element as Function of Total Power Radiated. Only a Small Fraction of Radiated Microwave Power Impinged Upon the Rectenna. Rectenna Efficiency cannot be Computed from Data Taken.

be the case experimentally as given by the following data, where Row 1 and Row 5 are the outside rows.

	<u>Row 1</u>	<u>Row 2</u>	<u>Row 3</u>	<u>Row 4</u>	<u>Row 5</u>
DC Power Output	7.4	5.5	5.9	5.8	7.8

These ratios of power levels of outside strings to inside strings was found to be about the same for total DC power outputs ranging from 30 to 120 watts.

In addition to the non-uniformity of pick up of outside and inside rows, the microwave beam itself was not uniform. An attempt was made to illuminate the 25 element rectenna uniformly using a sufficient separation from the mouth of the dual mode horn to allow the gaussian beam emitted by the horn to expand to a diameter so that the intensity of the radiation across the 25 element rectenna would be relatively uniform. On the other hand, the separation distance cannot be too great because the power density of the incident beam on the rectenna could fall below that needed to evaluate the rectenna at high power level. The distance of 100 inches proved to be a good compromise. The power density at the corners of the rectenna were 0.8 below that at the center, while the maximum illumination used on the rectenna necessitated nearly 1000 watts of power being radiated from the dual mode horn.

2.3.3 Temperature Rise of Diode in Rectenna Element as Function of Injected DC Power and Velocity of Convection Cooling Air

The injection of measured DC power into the diode and dissipated there provides a heat source of known value. This heat is generated in the same area as would be heat from microwave rectification losses, and it is conducted in the same manner as would be heat generated by microwave rectification into the same radiatively and convectively cooled structure. Because the dissipation in the diode represents 80% of the total heat generated in the rectenna element, when it is acting to convert microwave energy into DC power, these other sources of heat generation were ignored in computing efficiency. It is noted, moreover, that these other losses are much more uniformly distributed throughout the rectenna element and tend to dispose of the associated heat more efficiently than the diode. Their impact upon temperature measured at the diode is therefore limited.

The experimental arrangement for taking the data is shown in Figure 2-20. The data that resulted from noting temperature rise in the diode as a function of injected DC power and the velocity of the convective cooling air stream flowing by the single rectenna element is shown in Figure 2-22. The linearity of the data given in Figure 2-22 is an indication that the air flow over the rectenna surface remained laminar for all of the test conditions.

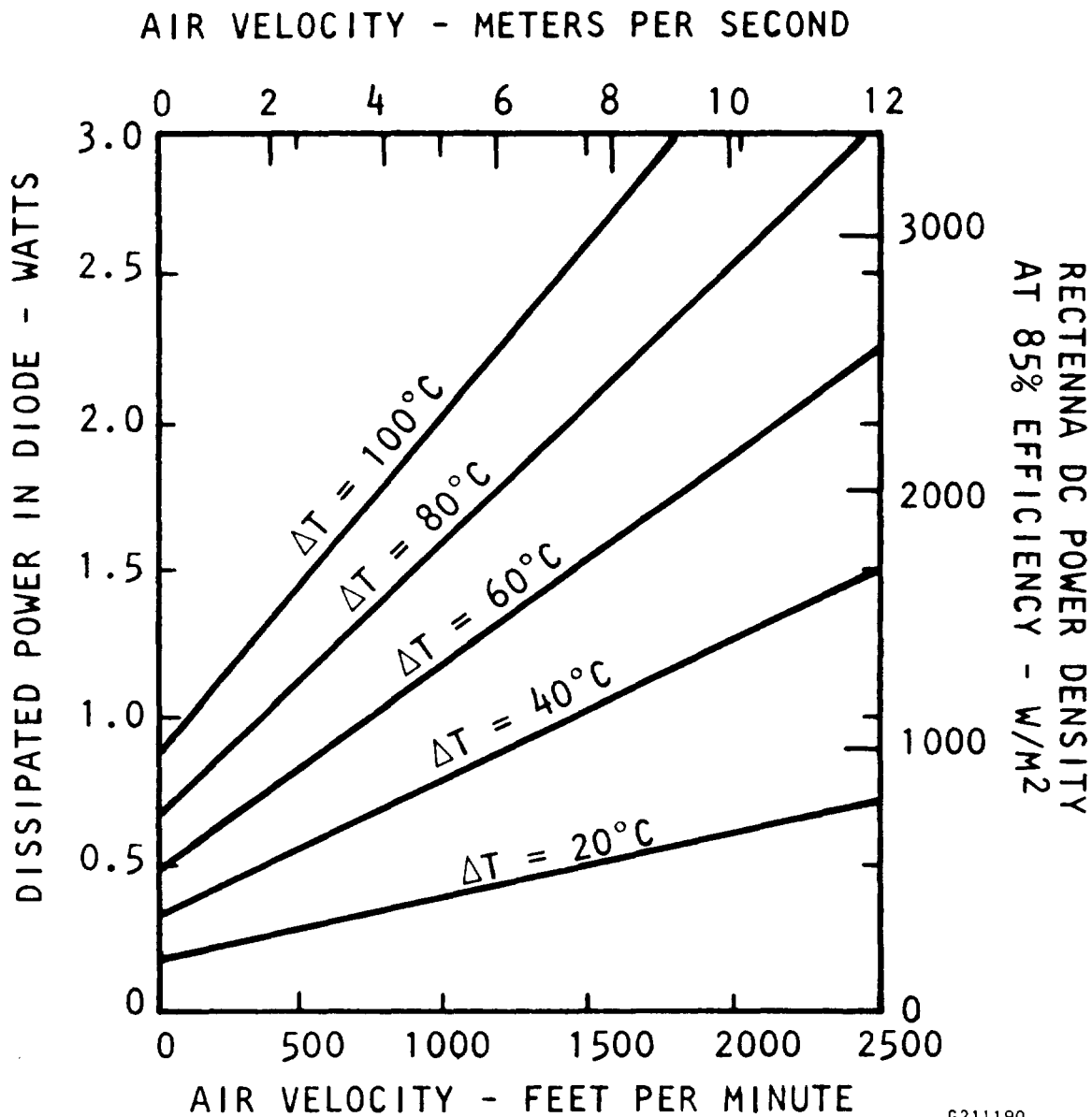

G211190

Figure 2-22. (a) Power Dissipated In Single Diode, as Function of Air Velocity and Diode Temperature (Left Hand Scale). (b) Equivalent Rectenna DC Power Density at 85% Efficiency (Right Hand Scale).

The data in Figure 2-22 can be used to develop equation 2 for diode dissipation as a function of air velocity and temperature rise of the diode case. The equation has two components. One component is that associated with convective cooling. The other is associated with residual cooling at zero air velocity and is assumed to be largely radiative cooling. Note that the linearity of the data and the low Reynolds number associated with the air velocity indicates laminar air flow at all time.

$$W = 1.125 \times 10^{-5} \Delta T_1 V + 0.009 \Delta T_2, \text{ where} \quad (2)$$

W = power dissipated in diode in watts

V = air velocity in feet per minute

ΔT_1 = °C increase in temperature of diode case above ambient air temperature

ΔT_2 = °C increase in temperature of diode case above temperature of sink for radiated power

Now if we know or make an estimate of the rectenna element efficiency, n , we can multiply equation (2) or the ordinate data on the left side of Figure 2-22 by the factor $n/1-n$ to obtain the DC power output of each rectenna element. For an assumed efficiency of 85%, a typical value for the rectenna element operated in the one to five watt output region, this factor will be 5.7. The corresponding DC power for one square meter which contains 200 elements is shown as the right hand ordinate of Figure 2-22 as a function of air velocity and diode temperature rise.

Equation (2) was derived from experimental data using mass flow rates of air at sea level density. If the term V in equation 2 is replaced by $V\rho/\rho_0$ where V and ρ are the air velocity and air density at any altitude and ρ_0 is the air density at sea level the same mass flow rate of air is maintained. If the assumption is made that convective cooling is proportional to mass flow rate of air alone, then the modified expression is applicable to any altitude and can therefore be applied to high altitude airplanes or balloons.

The expression becomes interesting when applied to very high altitude airplanes with the rectenna exposed to the air flow. Although the air density at an altitude of 20 kilometers is only 5% that at sea level, an airplane must fly at a velocity of about 70 meters/sec. to maintain altitude. This would be equivalent to an air velocity of 3.5 meters/sec. (714 ft./min.) at sea level. Figure 2-22 indicates that at this sea level velocity, and an assumed operating temperature of the diode case of 100°C above ambient, nearly 2000 watts of DC power output could be obtained from the rectenna, if the additional assumption is made that the diode efficiency is 85%.

The assumption of diode efficiency of 85%, corresponding to an inefficiency of 15%, is a conservative one. In Section 2.0 of Reference 6, diode losses were accurately measured to be 8% of the incident microwave power when the diodes were operating in the 6 to 10 watt region.

Although a minimization of cost analysis of microwave power transmission systems for the applications examined to date favor a moderate DC power density level from the rectenna, it should be noted that the power output from a single rectenna element could, with convective cooling, be easily upgraded to 25 to 50 watts of DC power output. This could be achieved by redesigning the rectenna element to match into a much lower DC load resistance, of the order of 30 ohms. The redesign should be relatively straightforward and would result in an optimum diode that would have a much larger diode junction area further increasing the power handling capability of the diode.

The final test performed on the single rectenna element was to illuminate it with microwave energy and note the DC power output and the temperature rise in the diode at a fixed air flow velocity. From this data, and with the use of Figure 2-22 and equation (1), it was possible to compute the operating efficiency of the rectenna element. The resulting data is shown in Figure 2-23. The similarity of this data with that obtained from a closed system for the rectenna element and presented in Figure 2-14 is of interest.

The technique of measuring diode temperature as a function of DC input power dissipated within the diode is of particular significance in determining the power handling capability of the rectenna in vacuum without having to apply any microwave power in vacuum. The procedure would be to first check the efficiency of the rectenna element outside the vacuum using test equipment similar to that shown in Figures 2-2 and 2-3.

The rectenna element is then inserted into the vacuum environment and its case temperature noted as a function of DC power injected into the diode to be dissipated there. Then at a specific case temperature, the power dissipation is known and the DC power output under assumed microwave radiation conditions can be found from the expression.

$$\text{DC Power Output} = \frac{n}{1 - n} (\text{Power Dissipated in Diode})$$

where n is the measured efficiency outside the vacuum.

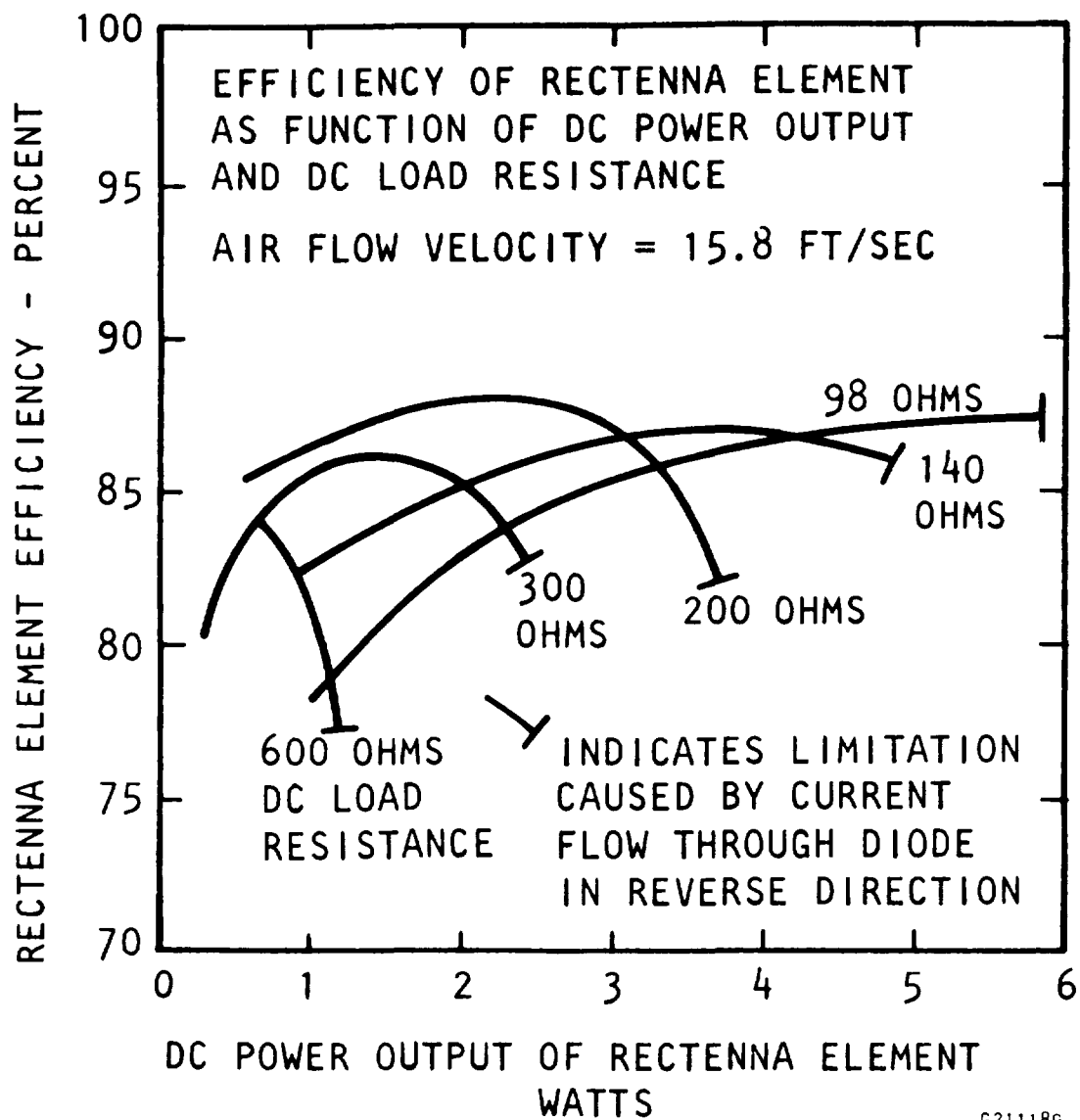

Figure 2-23. Efficiency of Rectenna Element as Function of DC Power Output and DC Load Resistance as Computed from Measured Dissipation in Diode and DC Power Output. Compare with Data of Figure 2-14 for Same Rectenna Element Measured in Closed Test Fixture in which Microwave Power Input could be Accurately Measured.

2.4 Design of an RF Test Facility (Task 4)

This task concerned the design of a suitable rf test facility to be built at Lewis Research Center for the purpose of testing the rectenna. The task was concerned not only with advice about the rf test equipment to be used but also with certain aspects of the testing procedure. A major consideration was that the tests were to be made in vacuum.

A testing procedure to be carried out in vacuum requires the measurements of DC power output from the rectenna and the operating temperature of the rectenna, with special emphasis upon noting the operating temperature close to the rectifying diode which will be the major source of heat and which is the most susceptible to heat damage.

It is also desirable to know the operating efficiency of the rectenna but it may be difficult to measure the incident energy of the microwave beam inside the vacuum.

However, it is possible to obtain efficiency values indirectly but quite accurately by passing a known amount of DC power through the diodes from an external source and noting the temperature rise of the diode case as noted in Section 2.3.2. With such a calibration, the efficiency of the rectenna with microwave power incident upon it can be calculated by noting the DC power output and the dissipated power that corresponds to the temperature at which the rectenna is operating.

The efficiency is given by:

$$\text{Rectenna Efficiency} = \text{DC Power Output} / (\text{DC Power Output} + \text{Dissipated Power})$$

A similar procedure of passing DC current through the diode for calibrating losses in the diode was used in the execution of a previous contract with LeRC.⁽⁶⁾

Considerable thought went into the matter of a suitable source of microwave power. The objective was to provide an economical source of power that can range from only a few milliwatts of power to as much as several hundred watts. The latter may be needed for subsequent testing of relative large sections of rectenna within the vacuum. The only economical way that such a goal can be approached is to make use of the microwave oven magnetron, which is readily available at low cost. A block diagram of the equipment involved in using the magnetron is shown in Figure 2-24.

The approach to achieving the immediately needed low power portion of the wide range power was to operate the magnetron into a matched waveguide resistive load through a ferrite circulator and to tap off a small portion of the total power through a probe penetrating into the waveguide. The power

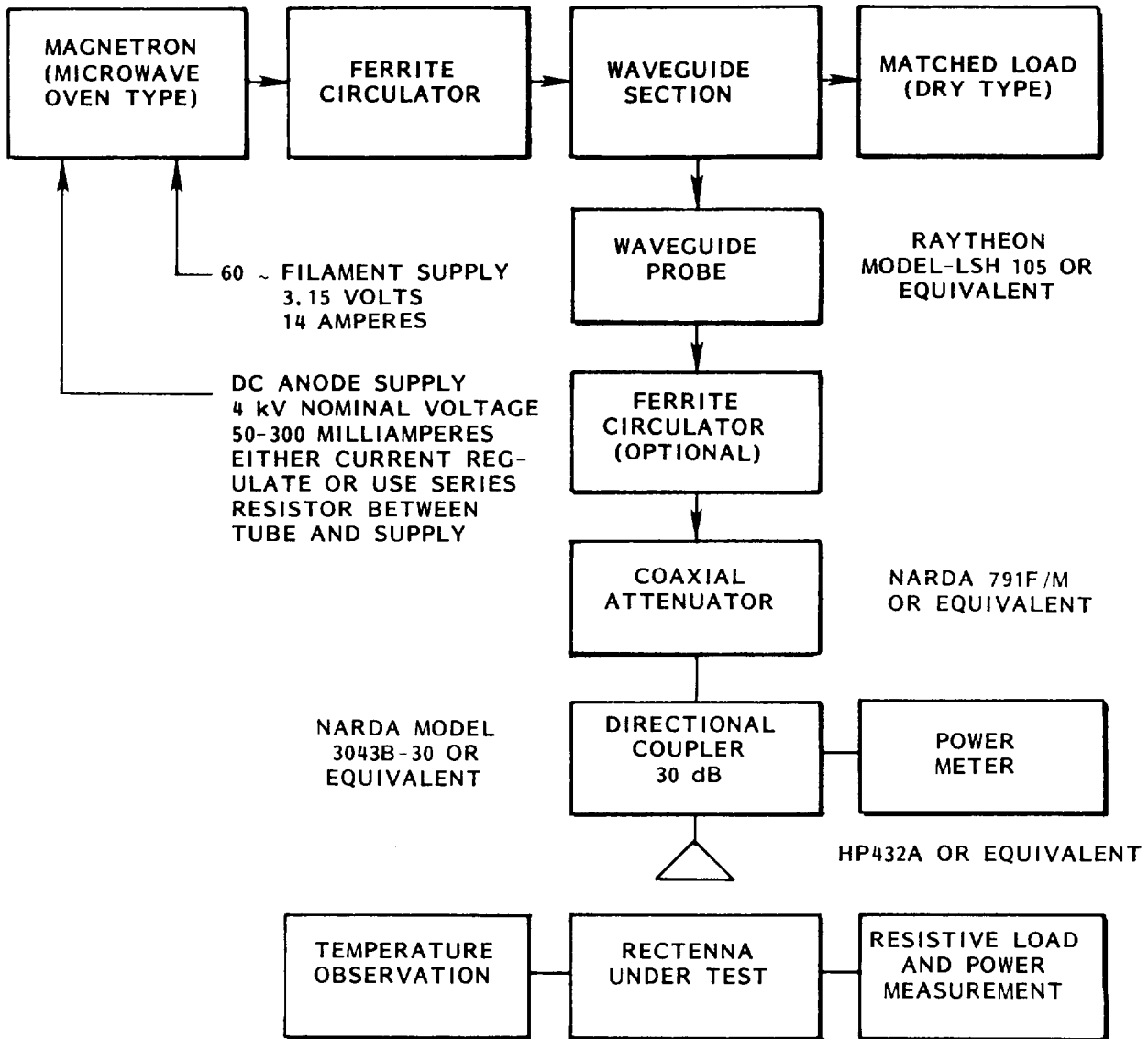

823876

Figure 2-24. Schematic of Test Arrangement.

picked up by the probe could be varied by the length of the probe and by the power level at which the magnetron was operated.

Once the power is picked up by the probe terminating a coaxial fitting, the power can be readily measured in a coaxial system that makes use of coaxial directional couplers and attenuators. This equipment is readily available in most laboratories, but it is also available at reasonable cost from many suppliers. The desired power may then be fed into a gain horn, open ended waveguide, or some other means of funnelling the power into the vacuum chamber. Substantial power may be reflected from the window, depending upon its thickness and dielectric constant. This power may be re-reflected from the probe end of the coaxial system and upset the power reading of the directional coupler. It would therefore be desirable to have a small coaxial ferrite circulator inserted between the coaxial probe fitting and the rest of the coaxial system.

The coaxial system can be used up to a power level of at least 25 watts, which should be adequate for the planned initial testing of a single rectenna element. For higher power levels the waveguide resistive load may be removed and the power fed directly into a suitable radiating device. The waveguide circulator will then absorb any power that may be reflected. If the reflected power level is high it will be necessary to apply a small fan to the resistive elements of the ferrite circulator.

In addition to helping plan the testing arrangements at LeRC, a magnetron, waveguide, and ferrite circulator were sent to LeRC without charge and with recommendations to buy a DC power supply for the magnetron. However, LeRC elected to buy a PGM-10X. This piece of equipment contains a DC power supply and a 90 watt CW magnetron. This power level is adequate for a broad range of testing, but for higher levels of testing the 500 to 1000 watt output of a microwave oven magnetron may be desirable.

2.6 20 GHz Printed Circuit Rectenna Study (Task 6)

2.6.1 Introduction

The purpose of this study was to investigate different approaches to constructing a rectenna at 20 GHz, and to recommend a specific approach for which the design of a single rectenna element would be developed under Task 7 (Section 2.7 in this report). Two approaches or formats were considered in the proposal submitted. One of these was to scale the present 2.45 GHz thin-film etched-circuit format to 20 GHz. The other was to use an interdigital format to form the capacitances and to keep all circuits on one side of the film to avoid a difficult dilemma in directly scaling the present structure. Both approaches would require the use of a beam lead diode.

After starting the actual study, however, it became quite clear that other approaches should be considered. Among these was a completely monolithic approach in which the diodes as well as all the circuitry are built up on a substrate of gallium arsenide or silicon. This would certainly be necessary at very high frequencies but the technique may be excessively expensive in the 20 GHz region.

It appeared that a good compromise might be to build a 20 GHz structure on an alumina ceramic substrate which closely resembles a semiconductor substrate in terms of dielectric constant. Beam lead diodes would then be bonded to the resulting structure. The approach was additionally attractive because of current thin and thick film technology based upon the use of alumina ceramic.

These different approaches are discussed in more detail in the following material, but it may be helpful to first approach the study from a more general point of view which is done in Sections 2.6.2 and 2.6.3. Section 2.6.2 discusses the frequency scale in terms of geometry, packing density, etc. Section 2.6.3 discusses the impact of any planning for future higher frequency scaling.

2.6.2 Significance of the Frequency Scale

The starting point for this study is the rectenna technology that exists at 2.45 GHz. However, the shift in frequency, a factor of 8.16, is so great that parameters of the resulting structure at 20 GHz are greatly modified.

Concentration of dipole antennas and diode elements. An exact scale of the 2.45 GHz structure to 20 GHz results in 13,300 elements per square meter instead of 200. The scale at 20 GHz along with a more reasonable scale at 8 GHz is shown in Figure 2-25. If placed on a high-dielectric material, the concentration of elements may be considerably greater than that shown in Figure 2-25 as examined in Section 2.7.3 and 2.7.4, perhaps as big as 30,000 elements per square meter.

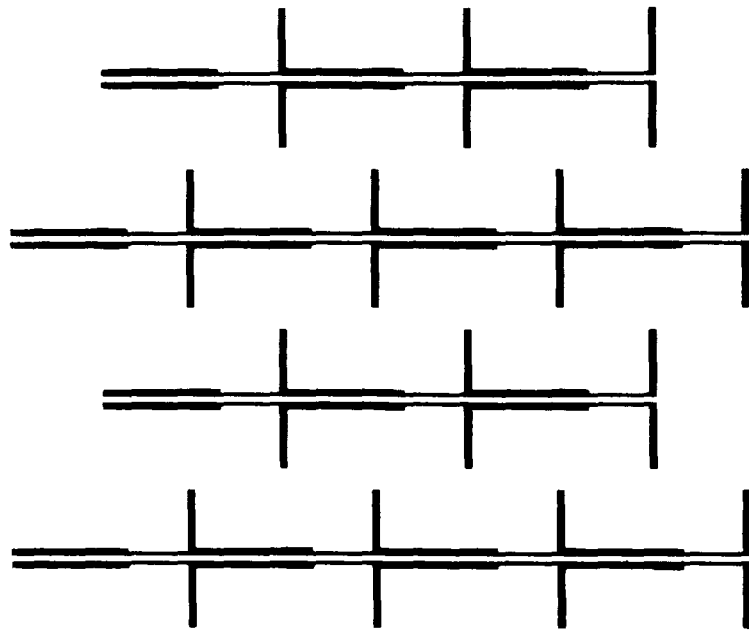

2.45 GHz Rectenna Scaled to 8 GHz

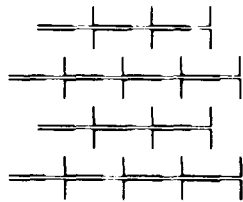

2.45 GHz Rectenna Scaled to 20.0 GHz

G221451

Figure 2-25. Large Scale Rectennas can be Scaled to Shorter Wavelengths by Simple Photographic Reduction. Above Material Illustrates Approximate Size of Rectenna for Different Frequencies when Scaled from Existing 2.45 GHz Format.

Spacing between foreplane and groundplane. An exact scale from the present 2 cm spacing at 2.45 GHz would place the new spacing at 0.245 cm or 96 mils. If a high-dielectric material were used to separate the foreplane from the reflecting plane, the separation will be even less.

Dissipation density capability. The power dissipation density increase because of the greatly increased number of rectenna elements even though the dissipation capability of the individual rectenna element is less.

If cooling the foreplane structure is aided by thermal conduction coupling to a continuous reflecting plane, the dissipation density can be greatly increased over that of the current 2.45 GHz thin film structure.

Efficiency. Efficiency must necessarily decrease. The losses in the diode will be considerably greater and the losses in the scaled circuit structure will become greater by the square root of the frequency scaling factor because of skin losses. The importance of efficiency in reducing heat dissipation problems is offset to some degree by the more effective conduction cooling of the scaled structure.

Power density levels. It may be that to keep the diode efficiency high it will be necessary to operate at DC power output levels per element of over 100 milliwatts. But the scale factor then would place the minimum DC power output at a power density level of 1340 watts per square meter. The DC power density level could be considerably greater than this if it were desired, particularly if the diodes were in good contact with a conductive substrate.

Rectenna cost. Rectenna cost per unit area will increase sharply, which of course favors using the device at its highest normal power density.

2.6.3 Significance of the Consideration of Work at Even Higher Frequencies Upon the Direction of the 20 GHz Experimental Program

The tendency of a high frequency scaled device to have a high packing density of diodes with a small junction area argues strongly toward an eventual monolithic approach in which the diodes and circuits are produced on the same substrate. This means a substrate of either gallium arsenide or silicon. This was an argument toward basing the 20 GHz work, upon a material whose dielectric constant is close to that of silicon or gallium arsenide. Alumina is such a material.

2.6.4 Discussion of the Different Approaches to a 20 GHz Rectenna

This section consists of the discussion of three approaches: (1) the direct scale of the thin-film, etched-circuit, 2.45 GHz rectenna; (2) use of the interdigital finger approach and the pedestal support which allows the complete

circuit to be laid down on one side of the dielectric substrate; and (3) the use of an alumina ceramic as the circuit substrate that fills the void between the foreplane and the reflecting plane of the rectenna and upon which the microwave circuit is printed. Conclusions and recommendations are then made in Section 2.6.6.

2.6.4.1 Direct Scale of the Thin-Film, Etched-Circuit 2.45 GHz Rectenna

Scaling the present structure is attractive in some respects but is unattractive in several others. One problem is that in a true scale the dielectric substrate would have to be decreased in thickness by the scale factor of about eight. Because of the lack of bonding materials (that bond the copper to the dielectric film) that are both very thin and of acceptable dielectric loss, it would be impractical to reduce the present sandwiched material from 2 mils to one quarter mil.

To compensate for the inability to scale the thickness, the capacitors in the low pass filter circuit section can be increased in area from the normal scale size but then they become quite large. It appears to be impractical to scale the shorting capacitance in the rectifier circuit to a larger area than the scaled size so that the capacitor would lose much of its effectiveness as a low impedance shunting circuit.

2.6.4.1.1 Application of Commercial Process for Vaporizing Metal on Thin-Film.

One way to cope with the scaled thickness problem is to use a different process for putting metal on a dielectric film. One approach is to vaporize a thin film of metal onto a thin dielectric film in vacuum. This general approach is commercially used in depositing a thin aluminum film on one or both sides of a dielectric film for the diverse uses of thermal insulation and food preservation. Such material is available in the form of aluminum deposited on Kapton only 0.3 mil thick, and on mylar only 0.25 mil thick.

The thickness of the metal film is, of course, very important in any potential microwave rectenna application, both from the viewpoint of conducting heat away from the diode to a radiating surface, and from the viewpoint of electrical conductivity. From the conductivity point alone, the deposit should be at least equal to the skin thickness which, at 20 GHz and for aluminum, is 57 microns. However, the commercial material is only available with a maximum thickness of about 8 microns. The material is put on with a thickness of about 1.5 microns per pass, so that it would take about forty passes to establish the minimum thickness desired. But a more important limitation is that, after a few successive passes, the adhesion between the aluminum and the dielectric film becomes poor. The reasons for this is not clearly understood, but because the present commercial markets do not need a thick film, there apparently has not been a substantial effort to develop an understanding.

From a technical point of view, it is relatively straightforward to deposit copper on a thin film in the same way that aluminum is deposited. However, it is not done commercially because no need has developed to do so.

One of the interesting possibilities to build up the thickness of the metal on the side of the film on which the dipoles and bus bars are etched is to first etch the microwave pattern on the metalized film and then to use the bus bar circuits to conduct current into an electroplating bath to build up the thickness of the microwave pattern to the desired thickness. If the plating operation were technically feasible, and it would be certainly so if the film first deposited was copper, the process would be a very economical way to produce a rectenna if the microwave circuits were all on one side of the film. There is, of course, no way to contact the patches of metalized material on the other side of the dielectric film that form the microwave capacitors for the low-pass filters. For this reason, the technology of placing the circuitry on one side of the dielectric film that is discussed in Section 2.2.4.2 is of interest. However, the resistive loss in the metal patches as laid down by the vaporization process may be acceptable under certain circumstances, but more study would be needed, possibly in the process of investigating the losses in Kapton at 20 GHz.

Going to this thin film makes it possible to design an adequate shunting capacitor in the rectifier circuit and it may not be necessary to put a patch on the other side of the film for this capacitor if the supporting pedestal approach discussed in the following section is used.

2.6.4.1.2 Application of the Pedestal Support Technique for Better Heat Dissipation and for Separating the Foreplane from the Reflecting Plane. A technique for improving the heat dissipation capability of the rectenna was discussed in the proposal. The suggested technique was to bond the electrically neutral patch associated with the shorting capacitor to a metallic projection or pedestal from the reflecting plane. The outstanding advantage of this technique is that it "short circuits" the heat flow that would normally be along the transmission line and into the antenna dipoles for radiation. Instead, the heat is conducted efficiently into the ground plane where the entire ground plane can be used for effective heat radiation.

Even though the patch is separated from the conductor that is directly attached to the diode by two mils of Kapton F whose heat conductivity is only 4×10^{-4} calories per second, per centimeter, per degree C, the thermal resistance in the 2.45 GHz case is only 10°C per watt of transmitted heat--considerably lower than the drop between the diode and the top of the capacitor. A direct scale to 20 GHz would increase this resistance to 80°C per watt of transmitted heat.

It is easy to visualize a reflecting plane with many support pedestals about 0.100 inch high that have been precision milled as a monolithic structure. The pedestals will now be so close together as to function as the sole support for the rectenna foreplane.

From a microwave circuit point of view, it is possible to employ this technique because of the balanced nature of the microwave circuit. The patch

that represents an essential part of the shorting capacitor in the rectifier circuit is at neutral or zero microwave potential and is not connected to the DC circuits. Hence, placing it in full metallic contact with pedestals from the ground plane does not impact the DC circuits and theoretically does not impact the microwave behavior of the device.

To experimentally check this assumption, the capacitor patch was bonded to the end of a one-half inch diameter aluminum rod whose other end was attached to the cover plane of the standard test fixture (see Figures 2-1 to 2-3). The cover plate serves as the reflecting plane of the rectenna. The test results, over a wide range of incident microwave power and DC load resistance, were nearly identical to the test made on the same element in which the capacitor patch was separated from the reflecting plane by two centimeters of air.

2.6.4.1.3 Registration of Microwave Circuit Patterns on Opposite Sides of the Dielectric. Although there is now no trouble in getting registration between the patterns on the opposite sides of the thin film at 2.45 GHz, it may be difficult to achieve registration at 20 GHz. But this does not mean that it cannot be accomplished.

2.6.4.1.4 Bonding the Beam Lead Diode to the Circuit. Normally, beam lead diodes are attached to circuits by thermal compression bonding. But the substrate is usually a hard material such as ceramic. The experience that the writer has had is that the Kapton is a soft material compared to ceramic and that the necessary pressure to make the bond pushes the copper circuit to which the beam lead is being welded into the Kapton. This is an area that would have to be studied further before proceeding with this general approach.

2.6.4.2 Use of the Interdigital Finger Approach to Forming Capacitors that Allows the Complete Circuit to be in One Plane

Figure 2-26 shows what the resulting circuit, except for the large shorting capacitor in the rectifier circuit, would look like if the interdigital capacitor technique were applied to the existing rectenna circuit at 2.45 GHz. One of the advantages of the etching of the microwave circuits in a single plane is that very thin dielectric film with vaporized metal coating on one surface only and as described in Section 2.6.4.1.1 may be used. Such a technology is also desirable for a monolithic approach to the construction of the rectenna element, as will be discussed in Section 2.6.4.3. And some of the objections to using the technique on a very thin film disappear when the interdigital fingers are placed on a thick substrate with a high dielectric constant, as would be the case in a monolithic structure.

2.6.4.2.1 Procedure for Designing Capacitors Formed by Interdigital Fingers. The design procedure for microwave capacitors formed by interdigital fingers is based upon the use of a formula for capacitance between many parallel flat strips of infinitely thin metal, with alternate strips constituting two sets,

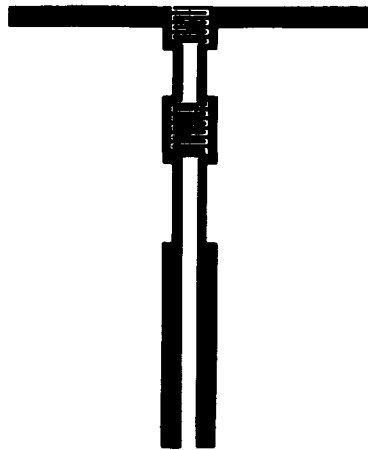

G221458

Figure 2-26. Application of Intedigital Finger Technique to Form Capacitors on One Plane as Applied to a Rectenna Element at 2.45 GHz.

each set conductively tied together and representing one side of the capacitor. The capacitance per unit length between any two of these fingers is as follows.

$$C = \frac{\pi \epsilon}{2 \ln \left[2 \cot \frac{\pi}{4} \frac{f}{f+d} \right]} \text{ Farads per centimeter}$$

where:

$$\epsilon = \frac{1}{36 \pi} \times 10^{-11} \text{ Farads per centimeter} \quad (1)$$

d = spacing between finger edges

f = width of each finger

This formula was experimentally checked out by measuring the capacitance between a set of 14 interdigital fingers, each 5 cm long, that were made from thin 0.40 cm wide copper strips spaced the same distance (0.40 cm) from each other on a thin piece of mylar. It was assumed that the mylar would have negligible impact upon the capacitance measurements. The measured value of the set of interdigital fingers was 5.5×10^{-12} Farad, which compares with a calculated value from the formula of 5.72×10^{-12} Farad.

The design of the capacitor then consists of a compromise between the number of fingers, their length, and their separation to provide the desired value of capacitance, using the expression (1).

2.6.4.2.2 Application of Interdigital Capacitor to Thin Film Rectennas. The difficulty in applying this technique to interdigital fingers on film so thin that it is assumed that the capacitance between fingers is not appreciably affected by the higher dielectric constant of the film is that the area taken up by the capacitor either has to be sizeable or the separation between fingers has to be very low. In Figure 2-26, the separation between fingers is 15 mils or 0.375 millimeter. This would scale to approximately 2 mils between fingers at 20 GHz.

The microwave shorting capacitor used in the rectifier circuit presents a difficult problem because the interdigital finger approach would require ten times the area of the capacitors for the low pass filter and would not therefore be practical. However, if the support pedestal discussed in Section 2.6.4.1.2 is used, then there may be no need for an interdigital capacitance in the rectifier circuit. The problem then, without a metal patch on the back, will be to position the pedestal so that the proper tuning of the rectifier circuit results.

2.6.4.2.3 Application of Interdigital Capacitor to Circuits on a Ceramic Substrate. If the interdigital fingers were completely immersed in dielectric material with a dielectric constant greater than unity, the capacity per unit length, as given by expression (1) in Section 2.6.4.2.1, would increase by the dielectric constant. If the material is alumina, the increase is a factor of 8.8. However, if the fingers are printed on top of an infinitely thick ceramic, the increase will be less than this. It cannot be assumed that the increase will be exactly half of the 8.8 or 4.4.

The capacitance between infinitely thin interdigital fingers on an infinitely thick slab of high dielectric constant material is undoubtedly an interesting theoretical problem. However, for design purposes, the increase can be experimentally measured. After mounting the set of interdigital fingers, used to check the expression for capacitance (in Section 2.6.4.2.1) on an alumina ceramic substrate, it was found that the capacitance had been increased by a factor of 5.22. Hence, the effective dielectric constant is 5.22 instead of 4.4.

The higher dielectric constant makes the use of the interdigital finger approach to a single plane circuit much more practical. The filter capacitances can be made without difficulty. And it is reasonable to expect that a solution can be found for the capacitor in the rectifier circuit with the much larger capacitance between a given set of fingers.

2.6.5 Use of Alumina Ceramic as a Microwave Circuit Substrate and as a Filler Between Foreplane and Reflecting Plane

This section discusses the advantages and disadvantages of the use of alumina ceramic, and in particular discusses the great advantage of transferring heat from the diode to a large heat sink. The increase in heat transfer is so dramatic that it is discussed separately in Section 2.6.5.2.

2.6.5.1 General Listing of Advantages and Disadvantages to the Use of Alumina as a Substrate

There are many advantages and comparatively few disadvantages in the use of alumina ceramic as a substrate. The advantages are:

- It eliminates an assembly operation of the foreplane to a supporting structure—certain to be difficult because of the small dimensions involved.
- It provides a hard surface for the thermal compression bonding of beam lead diodes to the structure.
- It provides an excellent low resistance thermal path for the dissipated power from the diode to flow to the reflecting plane which can be highly thermally conducting and treated to radiate heat efficiently. This is treated separately in Section 2.6.5.2.

- The high dielectric constant of an alumina substrate greatly increases the capacitance between fingers of an interdigital capacitor and makes their physical realization much easier.
- The microwave losses in pure alumina are quite low. Alumina in nearly pure form but with enough glass in it to make it vacuum tight has been satisfactorily used as windows in high powered microwave tubes for many years.
- The dielectric constant of alumina, 9, is close to that of silicon (11.8) and gallium arsenide (10.9). Such semiconductor material would presumably be used in a monolithic construction in which the diodes were constructed on the substrate. Using a ceramic substrate is a good intermediate step toward a monolithic structure.
- There is a large base of both thick and thin film circuit technology associated with ceramic substrates.
- The resulting structure is very compact--only one millimeter or less in thickness.

The disadvantages of an alumina substrate appear to be minimal. One problem is related to single plane circuitry, that of designing enough capacitance into the microwave shorting capacitor that tunes the rectifier circuit. However, the use of a high dielectric substrate makes it less of a problem. What is needed in this case is an investigation of the effectiveness of a very large number of interdigital fingers distributed over a substantial length of line. This will not look like a lumped capacitance at microwave frequencies but could possibly be as effective as a lumped capacitance. Even the present arrangement in the 2.45 GHz rectenna is not a lumped capacitance in the microwave sense.

Another possible disadvantage is the increased density of the elements. In a truly monolithic circuit with the diodes formed on the substrate, this would not be a disadvantage. And the power handling capability of the rectenna will increase with the packing density of the elements. It does become a disadvantage if it were desired to operate the rectenna at a low power density and to spread it over a large area, particularly if the diodes were separately constructed.

The ceramic construction might initially appear to be more expensive than other forms, and it certainly is at low frequencies, but it may well be the most economical at 20 GHz and above because it eliminates several difficult alignment and assembly steps that would have to be taken with other technologies.

2.6.5.2 Discussion of the Alumina Substrate as a Conductive Cooling Mechanism for the Diode

The bonding of the diode to a metal surface, probably gold, immediately above the alumina provides a cooling mechanism that is basically different from the approach currently used in cooling the 2.45 GHz thin-film, etched circuit rectenna, and even the pedestal technique (discussed in Section 2.6.4.1.2) where the heat still has to flow through a section of the transmission line before reaching the pedestal. When a ceramic substrate is used, the heat can flow directly from the diode to the reflecting plane where it can be radiated or transferred to a convective coolant.

Because alumina ceramic is a good heat conductor, 0.055 calories/degree C/cm/sec, and the space between the foreplane and the reflecting plane is only about 1 millimeter for a 20 GHz rectenna, the resistance to heat flow from each diode to the reflecting plane is relatively low. This fact, along with the high packing density of the diodes, allows several kilowatts of heat to be transferred for each square meter of surface area of the rectenna.

This conclusion may be supported by a simple mathematical model of heat flow from the heat-sinked diode to the reflecting plane. The model assumes that heat flows through a 90° truncated cone from the diode to the reflecting plane. The quantitative results of the use of this model are expected to be close to those for a much more complicated model that would simulate the real situation.

The resulting expression is:

$$W = (0.72) \frac{x_1 x_2}{x_2 - x_1} (\Delta T) \quad (1)$$

Where

- W is the heat flow in watts from each diode.
- ΔT is the temperature difference between x_1 and x_2 .
- x is the distance from the tip of the cone.
- x_1 is the position of the heat sink of the diode, and because of the 90°C cone assumed, is also the radius of the heat sink.
- x_2 is the distance of the reflecting plane from the tip of the cone, and is equal to the thickness of the ceramic plus x_1 .

If the assumption is made that the radius x_1 of the heat sink of the diode is 0.00125 cm and the thickness of the ceramic is one millimeter, x_1 and x_2 become 0.00125 cm and 0.10125 cm respectively. When these are inserted into expression (1)

$$W = 0.0009 \Delta T \quad (2)$$

If $\Delta T = 100^\circ\text{C}$, certainly a conservative value, W becomes 0.09 watts for each diode. As indicated in Section 2.6.2, there could be 30,000 diodes per square meter in a 20 GHz rectenna. Thus, there could be 2,700 watts of heat flow for each square meter of rectenna. If the rectenna were only 60% efficient, it could handle 4,050 watts of power per square meter. Semiconductor substrates have a higher coefficient of heat transfer. For the same dimensional parameters and efficiency 12.5 kW/m^2 could be obtained with GaAs (see Section 2.7.2.2).

However, the reflecting plane to which the heat is transferred would have to be convectively cooled with air or liquid, since its radiation capability for a scenario of 150°C surface temperature, 30° ambient temperature, and emissivity of 0.5 is only 669 watts for one side and 1338 watts for both sides.

2.6.6 Conclusions and Recommendations

A firm conclusion resulting from this task was that the 20 GHz rectenna should use a solid dielectric separator between the rectenna foreplane and the reflecting plane. Two different constructions were considered. One was a hybrid construction consisting of an alumina substrate, silk screened circuits, and beam lead diodes. The other was a monolithic construction utilizing a semiconductor substrate. But because of the anticipation of actually constructing at least one rectenna section, with the only possible available form of diode being the beam lead diode, the hybrid construction was favored.

This approach proceeded to the point of making a search for beam lead diodes and procurement of ceramic substrates. However, as an appreciation of the difficulty of the task of putting just one element together grew, the enormity of the task of building a large rectenna area with the hybrid technology also grew. As indicated in the introduction to the next section (2.7) the monolithic construction turned out to be the recommended approach even though the recommended material GaAs was still an imperfect material. However, most of the work in Section 2.6 is applicable to the monolithic construction, including the interdigital approach to a single surface microwave circuit and the determination of diode dissipation capabilities.

2.7 Preliminary K-Band Rectenna Design (Task 7)

2.7.1 Introduction and Summary

The investigation of various approaches to the design and construction of a 20 GHz rectenna carried out in Section 2.6 (Task 6) found that the best approach for a non-monolithic structure would be a ceramic substrate with the microwave circuits silk screened upon it. The capacitors in the low pass filter circuit would be interdigital as shown in Figure 2.6.2 and as discussed in Section 2.6.4.2.3. The diodes would be beam lead diodes bonded to the silk screened gold transmission lines by thermal compression. The metallic reflecting plane would be deposited on the back side of the ceramic substrate. One remaining problem would be the bypass capacitor which would be of the order of one picofarad and could not be built in the interdigital format.

It was felt, however, because of the very large number of diodes that would be needed per unit area, that a completely monolithic structure would probably be the eventual answer with the diode fabricated on a silicon or GaAs substrate. In fact, at the time of writing the final report, GaAs monolithic technology was moving rapidly enough to perhaps justify the bypassing of the non-monolithic technology altogether if only a few rectenna elements were to be constructed for evaluation and demonstration purposes.

When the study in Section 2.6 was performed there was the hope of actually fabricating one or two non-monolithic rectenna elements including diodes at 20 GHz, and testing them during Task 2.7. That objective, together with the state of monolithic technology, less mature than now, encouraged the study in Task 6 focus on non-monolithic technology. That situation has changed.

There has also been the tendency to steer away from monolithic technology because of its perceived high cost. But it should be recognized that rectennas made at 20 GHz and higher with any technology will be expensive. Monolithic technology may not only be better than non-monolithic technology at 20 GHz but it is the only approach at frequencies significantly above 20 GHz.

The next section of this report, 2.7.2, will contain approaches to the fabrication of the monolithic rectenna as suggested by the Raytheon Research Division, who currently are fabricating what they feel are much more complex monolithic circuits than that represented by the rectenna. According to them, it would be quite feasible to fabricate a few rectenna sections on a selected area of a GaAs wafer. However, the quality of the material throughout a 3 inch GaAs wafer is currently not good enough to utilize the whole wafer without probably having an appreciable percentage of defective diodes.

Section 2.7.2 will be followed by Section 2.7.3 which is devoted to a scaling of the antenna portion of the K-band rectenna element as designed for an alumina or GaAs substrate to 2.45 GHz where extensive cold tests were made

to match the rectenna structure to space. From this work, the length of the rectenna dipole and the thickness of the ceramic substrate were determined.

The match was then checked out in "hot test" with the balance of the thin-film rectenna element in the 2.45 GHz expanded waveguide test fixture. The "hybrid" element was found to perform at high rectification efficiency and with an acceptable amount of reflected microwave power.

In concluding the summary aspect of the introductory section it is necessary to point out that the rectenna design presented here is the first iteration of the design. During this first iteration unexpected inputs occurred when the individual rectenna element was integrated into the complete rectenna. This was caused in part by the early emphasis upon attempting to make a rectenna element for test, and in part by the successfully used procedure in the past to concentrate upon the individual element development before consolidating it into the rectenna.

The unexpected difficulty encountered in this instance was the bus bar loss caused by the much smaller cross section because of the scaling and the generally higher power density of the DC power output. To keep the bus bar power losses to within reasonable limits, 2 to 5%, the thickness of the bus bar would have to be 2 to 3 mils thick. This would undoubtedly cause difficulties first in building up such a layer on the gallium arsenide substrate and then in the mechanical shear stresses at the interface caused by the difference in the coefficient of expansion. The coefficient of expansion of GaAs is $5.9 \times 10^{-6}/^{\circ}\text{C}$ while copper and gold are $9-10 \times 10^{-6}/^{\circ}\text{C}$.

Fortunately, there may be a solution to the problem by connecting the DC outputs of the elements in series rather than in parallel. There is some precedent for this in that the rectenna elements of early successful rectenna were connected in series. However, this possible solution would have to be investigated in more detail, particularly in the context of rectenna stability.

Another element that was recognized later in the study was that the sections of transmission line that are needed as the inductive element in the low pass filter have a low characteristic impedance because they are laid down on a material with a high dielectric constant. This low characteristic impedance makes it difficult to make a low pass filter with a sufficiently high characteristic impedance to match the rectenna element into a high value of DC load resistance, for example, 200-400 ohms. The indication then is a lower resistive load, perhaps in the 100 ohm range.

It is difficult to predict the results of a reiteration of design that takes a lower impedance level into account. There are benefits as well as non-benefits. A low characteristic impedance means that the C_{t0} of the diode can be made larger, thereby increasing the capacitance of the diode and reducing the series resistance and increasing the thermal dissipation of the diode-both

benefits. On the other hand, the DC voltage output will be less so that the Schottky barrier losses become more important. It can be concluded, however, that operation at a high power density level is highly desirable for efficiency purposes.

2.7.2 Conceptual Design of a Monolithic Rectenna at 20 GHz

The design of the physical layout of a monolithic rectenna at 20 GHz and higher frequencies consists of two parts. The first part is making the diode on the semiconductor substrate so that it can be connected properly to the microwave circuit. The second part is the layout and construction of the microwave circuit. We will review the design of the diode first.

2.7.2.1 Diode Design for 20 GHz Monolithic Construction

The diode design will be reviewed from the viewpoints of fabrication procedure, specification of design parameters such as C_{T0} , reverse breakdown voltage, etc., and dissipation capability. An extrapolation will also be made to higher frequencies.

Fabrication Procedure

The construction of a Schottky barrier diode by epitaxial growth and metallization on a semiconductor substrate base is shown in Figure 2-27. It is assumed that the substrate is Gallium Arsenide but the construction would be similar for silicon. The first thing that is done is to lay down as highly a doped layer, "N"+, as possible by epitaxial deposit on the substrate to serve as a low resistance conduction path. Then an epitaxial layer of "N" GaAs that is doped in the proper amount and to the allowable minimum thickness is set down. Then small areas of "resist" (to resist etching) that correspond to the appropriate area of the Schottky barrier interface are laid down and the underlying structure is etched away to include some of the N+ area. An upward projection of the diode like a "mesa" results and gives the "mesa diode" its name.

A metal contact is then deposited on top of the mesa to form the Schottky barrier itself. This metal is often platinum but it can be other material. Tungsten is a material that results in a lower voltage drop across the Schottky barrier and therefore improves the efficiency of the diode, particularly at low DC voltage output of the diode.

The diode itself is now complete but it will be necessary to make a contact between the metal side of the Schottky barrier and one side of the microwave circuit, and to make a contact between the back side of the diode and the other side of the microwave circuit.

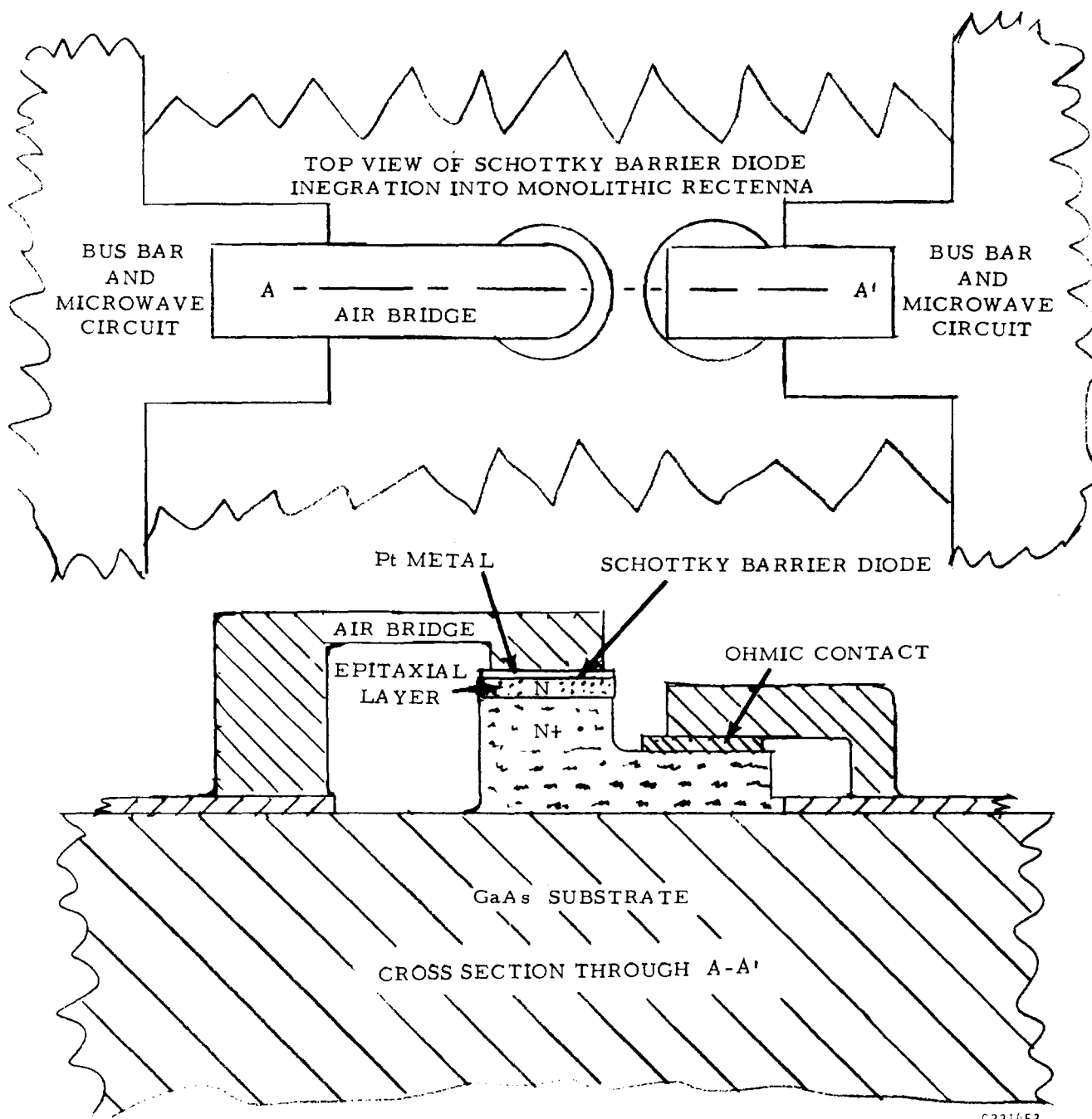

Figure 2-27. Diagram Illustrating the Schottky Barrier Diode Rectifier Portion of the GaAs Monolithic Structure for a Rectenna Element.

The contact with the top of the mesa diode is accomplished by a technique known as air bridging. Although other methods of contact could be used, and would be used in other approaches to the design of the diode, the air bridge has a unique advantage. Early in the development of the rectenna the ability of a diode short to disable the rectenna unless there was the equivalent of a fuse in series with it was recognized and fuses have been built into the packaged diodes since. In the monolithic rectenna, many diodes are operated in parallel across the DC bus. If a short occurs within one of the diodes, the short-circuit currents from the other diodes pass through the air bridge which will be very small in cross section and will act as a fuse. After the air bridge is burned through the rest of the rectenna elements return to normal operation.

From Figure 2-27 it is noted that the other side of the diode is connected to the other side of the microwave circuit through the N+ GaAs and an ohmic contact. The ohmic contact can be processed by applying "resist" to all the surface except the point at which the ohmic contact is to be made.

To reduce the resistance to current flow through the N+ material it is doped as much as possible to a level of 10^{18} , giving it a resistivity of 0.002 ohm cm. Although the path to the back contact is fairly long, the current has ample opportunity to spread out and this action coupled with the low resistivity makes the diode design approach acceptable.

Selecting the Initial Diode Design Parameters to Determine Internal Losses and Power Handling Capability

It is possible to initially select, largely on the basis of experience, design parameters of the diode from which it is possible to predict typical internal losses and the power handling capabilities of the diode. A final diode design would depend upon a number of reiterations that would probably be associated with the application of the rectenna and the environment in which it would be operated.

At the level with which we will deal with the design it is adequate to characterize the diode as an ideal rectifier with a capacitance in shunt with it, and a resistance in series with the combined diode and capacitance. The value of the capacitance varies with the potential across it, and it is typical to define this capacitance as that value it takes on when there is no voltage across it. This is called C_{t0} , or the zero-bias capacitance.

The series resistance R_s is very important in determining the efficiency of the diode. In the conduction portion of the rectification cycle the DC current flows through it, while on the non-conducting portion the charging current to the capacitance C_{t0} flows through it. The value of R_s depends upon the semiconductor material used, the doping density of the epitaxial layer, the thickness of the epitaxial layer, and the area of the Schottky barrier junction.

Another important parameter is that value of inverse voltage applied to the diode at which the diode starts to conduct in the reverse direction. This value of voltage is denoted V_b and its value is typically 2.5 times the DC output voltage of the rectifier, to allow for a peak inverse voltage also 2.5 times the DC output voltage. The parameter V_b determines the doping density of the epitaxial layer and its minimum thickness, and thus, in combination with the area of the junction, the series resistance R_s of the diode.

The first step in the design procedure was to select a value of C_{t0} that is based upon retaining the microwave circuit impedance level of the 2.45 GHz design, and to scale the capacitance C_{t0} by a factor equal to the ratio of the frequencies which is a factor of approximately 8. The C_{t0} of the 2.45 MHz diode was 3 pf which implies a scaled value of 0.375 at 20 GHz.

As previously pointed out, another important parameter to specify initially is the reverse voltage breakdown, V_b , of the diode because this controls the doping density, the capacitance C_{t0} per unit area of the junction, and the thickness of the epitaxial layer which along with the junction area controls the series resistance. It is assumed for an initial design that this voltage, V_b is 20 volts.

Given the reverse voltage breakdown of 20 volts, it is determined that the doping density should be 7×10^{16} atoms per cubic centimeter. (Figure 23, Chapter 5 of Reference 9.) For this doping density the zero bias capacitance will be about 70,000 pf/cm². (Figure 9, Chapter 3 of Reference 9.) The area of the Schottky barrier diode will then be $0.375/70,000$ or 5.3×10^{-6} cm². This corresponds to the area of a circle with a diameter of 2.58×10^{-3} cm, or roughly 0.001 inch.

The thickness of the epitaxial layer may be obtained from the depletion layer which for a doping density of 7×10^{16} is 0.6 microns (Figure 25, Chapter 5 of Reference 9). Conservative design, however, would increase this to 1.0 micron thickness.

The resistivity of GaAs doped to 7×10^{16} is 0.08 ohm-cm. (Figure 22, Chapter 5, of Reference 9.) So for an epitaxial volume that is one micron thick (0.001 cm) and 0.00258 cm in diameter, the resistance R_s will be approximately 6 ohms. This resistance enters into the overall efficiency of the diode in complex ways but if the DC resistance level is in the range of 200 to 400 ohms, its impact on the overall efficiency will be a multiplying factor of about 0.9.

The comparable series resistance for silicon would be 30 ohms which would reduce the overall efficiency significantly. The situation will become even worse at higher frequencies because of the progressively smaller size of the junction area and no relief in the thickness of the epitaxial layer if the same breakdown voltage is to be maintained. It would therefore appear that the use of GaAs for high frequency rectennas is almost mandatory to retain a useable efficiency.

2.7.2.2 Dissipation Capabilities of the Diode and Its Power Handling Capability

The heat dissipation capability will now be examined with the aid of equation (2) in Section 2.6.5.2. Gallium arsenide with a heat conductivity of 0.64 watt/cm°C is a better heat conductor than is alumina so the first term in equation (2) become 2.0 for Gallium Arsenide. Now the expression (2) with X_2 much greater than X_1 , as it is in the situation under discussion, is approximated by the term $2X_1$. X_1 for the 90° cone angle assumed for the heat flow is the same as the radius of the Schottky barrier junction which was 1.29×10^{-3} cm. Therefore the heat flow away from the junction, if the cooling is done only by heat flow to the backplane, is $0.0026 \Delta T$, where ΔT is the temperature difference between the diode and the back plate.

The determination of an expression for the approximate dissipation capability of the diode may now be used to approximately determine the DC output of the rectenna element in terms of the diode efficiency and ΔT . Although there are other losses in the rectenna element that should be taken into account in a more exact analysis, the losses in the diode are the predominant losses. The approximate expression becomes.

$$P_{dc} = \left(\frac{n}{1-n} \right) \text{ (Power Dissipated in Diode)}$$

$$= \left(\frac{n}{1-n} \right) (0.0026 \Delta T)$$

Where P_{dc} = DC power output from rectenna element

n = efficiency of diode

ΔT = temperature differential between diode and back plate

Figure 2-28 gives the contours of constant P_{dc} as a function of diode efficiency and ΔT .

From this figure it would appear that an expected DC power output in the range of 0.4 watts per diode element would be reasonable. What does this mean in terms of watts per square meter? On a strictly scaled basis the 200 elements per square meter in the 2.45 GHz array would scale the factor 8^2 to 12,800 elements. It is probable, however, that the elements will be much more densely packaged because of the high dielectric constant of the substrate. Thirty thousand elements would be more likely. Therefore, with a single rectenna power output of 0.4 watts, the power output per square meter would be 12.5 kilowatts.

This figure of 12.5 kilowatts assumes that the reflecting plane is conductively or convectively cooled in some manner. For an atmospheric application this is relatively easy to accomplish. However, for space applications

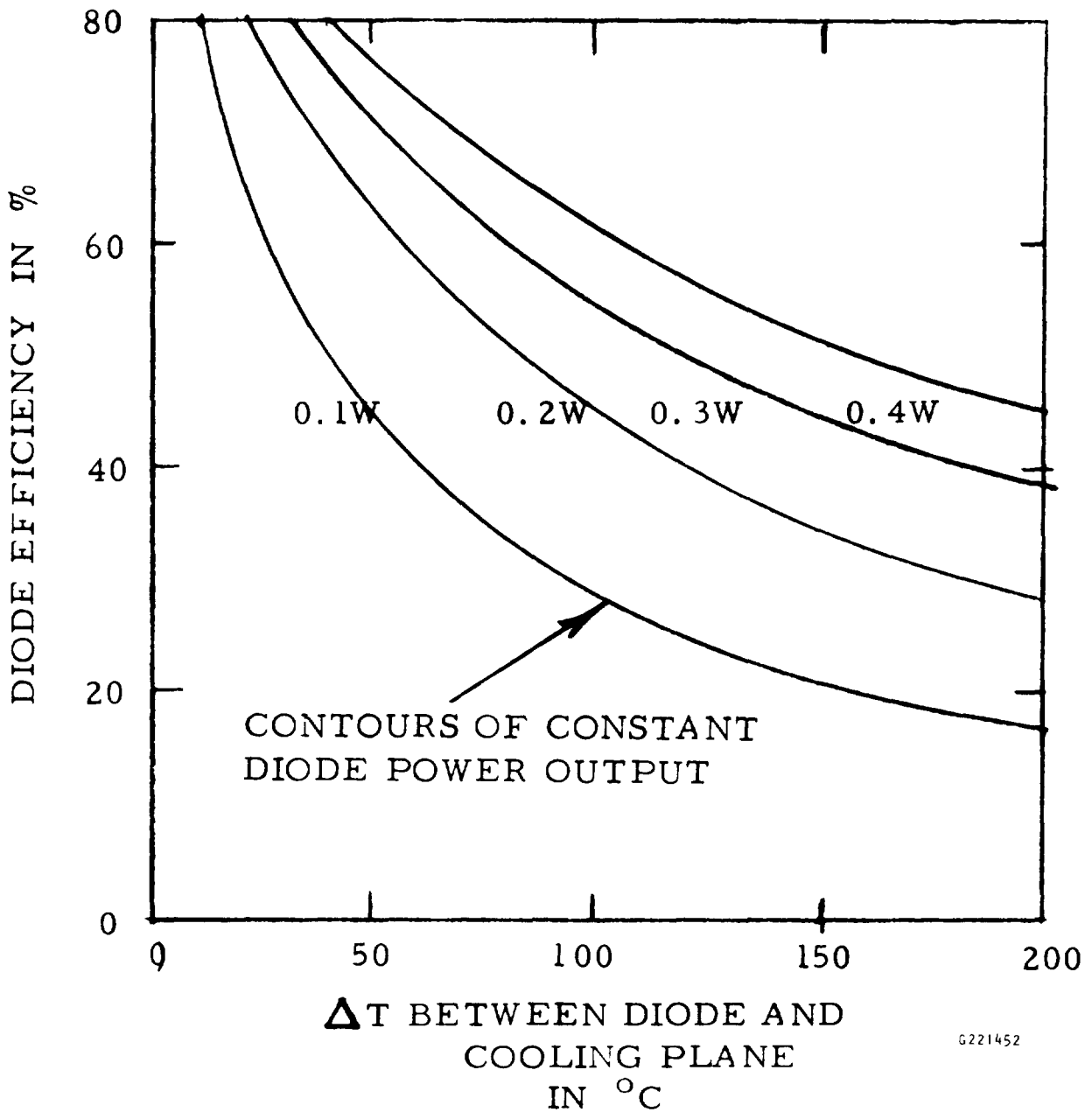

Figure 2-28. DC Power Output of Diode as Function of the Diode Efficiency and the Temperature Difference Between the Schottky Barrier of the Diode and the Reflecting Plane of the Rectenna Array. Assumptions are a GaAs Substrate, a Frequency of 20 GHz, and a Diode Spot Size of 0.00254 cm Diameter.

it may be necessary to rely upon heat radiation directly to space. If the reflecting plane is operated at 100°C , the maximum (black body) radiation to space from the back plane at a temperature of zero degrees Kelvin would be 1.09 kW . However, the front surface would probably be at nearly the same temperature, doubling the radiation to space. After making allowances for radiation into a higher ambient than 0°K and an emissivity of less than 1, radiated power in the range of 1 Kw/m^2 is more likely. This would seriously restrict the amount of DC power output from the rectenna. If the efficiency were 70%, the DC power output would be 2.33 Kw/m^2 .

2.7.2.3 Output Voltage of the Rectenna Element

With a DC power output of 0.4 watts and a DC load resistance of 200 ohms, the DC output voltage would be 8.9 volts. The corresponding peak inverse voltage of 22.4 volts would exceed the reverse voltage breakdown of 20 volts established for the tentative initial design. However, with a limitation of 0.1 watt per diode which might well be the case for a radiation cooled rectenna, the DC voltage for a 200 ohm load would be only 4.5 volts.

2.7.2.4 Scaling to Higher Frequencies

Reasoning from the design sequence for the 20 GHz diode, it is reasonable to expect that the junction area will scale down directly with frequency, the internal resistance will scale up with frequency, and that the design dissipation capability of the diode will scale inversely as the square root of the frequency. However, the number of rectenna elements will scale up as the square of the frequency so that the number of diodes scales as the square of the frequency. The total dissipation of the diodes will then increase as the square root of the frequency. However, the series resistance is increasing to a significant value that will seriously impact the efficiency. Without a more detailed study and some experimental data for comparison purposes, the quantitative performance cannot be accurately predicted.

2.7.2.5 Microwave Circuit Design

The other part of the physical layout is the microwave circuit. It will be patterned after the technology discussed in Section 2.6.4.2 and Figure 2-26. It will be interdigitated. Some study will have to be made on whether the interdigital microwave circuits are laid down on the substrate before or after the construction of the diodes, but this should not present a serious problem.

The minimum thickness of the films laid down as part of the microwave circuit is controlled by the skin thickness which is a function of the microwave frequency. At 20 GHz the skin depth in copper is 57 microns. A thickness double this or 114 microns would be adequate for microwave conduction even after allowing for current flow on both sides of the conductor. The corresponding thin film resistance (resistance to flow of microwave power) is

0.023 ohms per square. The conductors in the microwave circuit (per rectenna element) as scaled from 2.45 GHz are 0.3 cm long and 0.020 cm wide. There are about 15 squares in one of these conductors or 30 squares in the loop of two conductors. Because the current flows on both sides, the total microwave resistance is 0.69 ohms. If the conductors are of gold the resistance will be a little higher. Also the current will tend to accumulate on the inner surfaces of the conductors which will increase the resistance somewhat. But the values will be sufficiently low so that the rectenna element efficiency will not be seriously impacted.

The microwave conductors are also used as DC bus bars, to collect the rectified power. How thick will they need to be? The cross section of the bus bars and their length will determine the DC bus bar resistance and therefore bus bar losses. The resistance of the bus bars will be in series with the equivalent load resistor at the end of the row of diodes that are parallel together. If each rectenna element is to look into 200 ohms then the DC resistance across the bus bar will be 200 divided by the number of elements in parallel. The number in parallel on a 3 inch wafer could be typically 20, leading to a typical DC load resistance of 5 ohms. If it is desired to keep the bus bar losses to only 2% of the power output, then the equivalent resistance of the bus bar can be only 0.10 ohms. The loop length of the bus bar to service the 20 diodes, on the 3 inch wafer is 15 cm. If the bus bars average 0.04 cm in width, then it will be found that the thickness of a copper bus bar must be 0.003 cm, or 3000 microns, or 1.0 mil thick to keep the bus bar losses to 2%. This calculation reflects the reduced thickness needed because the full current is flowing in the bus bars only at the output end while no current is flowing at the input end, reflecting the fact that the diodes appear as generators evenly distributed along the length of the bus bars.

The 3000 micron thickness required for bus bar efficiency is 26 times the thickness needed to minimize microwave losses, and represents a challenge in the design and processing of the monolithic circuits. Of course, the bus bar thickness can be cut down by using fewer diodes in parallel, and by operating into a higher DC load resistance that in turn reflects the choice of a higher impedance level for the microwave circuit. But still the bus bar thickness will be much larger than that needed for the microwave circuit.

As explained in the summary in the introduction (Section 2.7.1) the necessity for heavy bus bars can be eliminated by connecting the elements in series, and indeed this has already been done in some of the early work on rectennas. From a monolithic device technology point of view this appears to be possible, and could have some additional advantages in eliminating the air bridge fuses if it is presumed that the failure mode of the diode is an internal short that would remain a short. Typical voltage outputs from 20 elements connected in series could range from 100 to 200 volts which would presumably be a generally convenient value of voltage to work with.

Also, as noted in the Introduction it may be difficult to maintain a high characteristic impedance of the low-pass filter sections at the input to the rectenna element. This situation will lead to modifications that will improve the dissipation capability of the diodes but at the expense of increasing the percentage of total power that is dissipated in the Schottky barrier. A combination of these considerations will force the rectenna power level upward to maintain efficiency.

2.7.3 Matching a Dipole that is Mounted on a Ceramic or Semiconductor Substrate

The previous sections have discussed both a monolithic rectenna with integration of the diode and microwave circuits and a hybrid rectenna that consists of an alumina substrate with silk screened circuits and separate beam lead diodes bonded to the circuits. In both of these approaches the necessity arises to match these structures to space so that the incoming microwave beam is effectively absorbed into the structure. This section discusses experimental efforts that were successful in matching an antenna on an alumina substrate to space. Because the dielectric constants of the semiconductor materials GaAs and Silicon are very close to that of alumina the results will be applicable to monolithic type rectennas.

Because it would be difficult to perform the experimental work at 20 GHz both because of test equipment considerations and because of the high precision required in laying out the physical parts of the experiment, the work was carried out at 2.45 GHz. However, the results can be readily scaled to any other frequency including those much higher than 20 GHz.

For these experimental measurements it was most desirable to use a Hewlett Packard network analyzer. The output of these analyzers, of course, is in the form of a coaxial output that is unbalanced with respect to ground while the rectenna dipole inputs are balanced with respect to ground. However, the rectenna circuit can be split in half by establishing a ground plane as illustrated in Figure 2-29. The center conductor of the HP network analyzer output is connected to one side of the dipole antenna while the outer conductor is connected to the ground plane. It is, of course, necessary to incorporate the reflecting plane of the rectenna into the set-up shown in Figure 2-29. The reflecting plane of the rectenna should not be confused with the ground plane of the measurement set up.

The varying input impedance of the radiating dipole as seen from the network analyzer terminals was obtained as a function of thickness of the ceramic substrate and the length of the dipole as shown in Figure 2-30. Conditions were found for a reflectionless match from a 100 ohm source. The 100 ohms corresponds to the 50 ohm impedance of the HP network analyzer source used in conjunction with the rectenna dipole element sliced in half with the use of the ground plane because the impedance level of the rectenna element is halved by this procedure. The match was obtained with an antenna length of

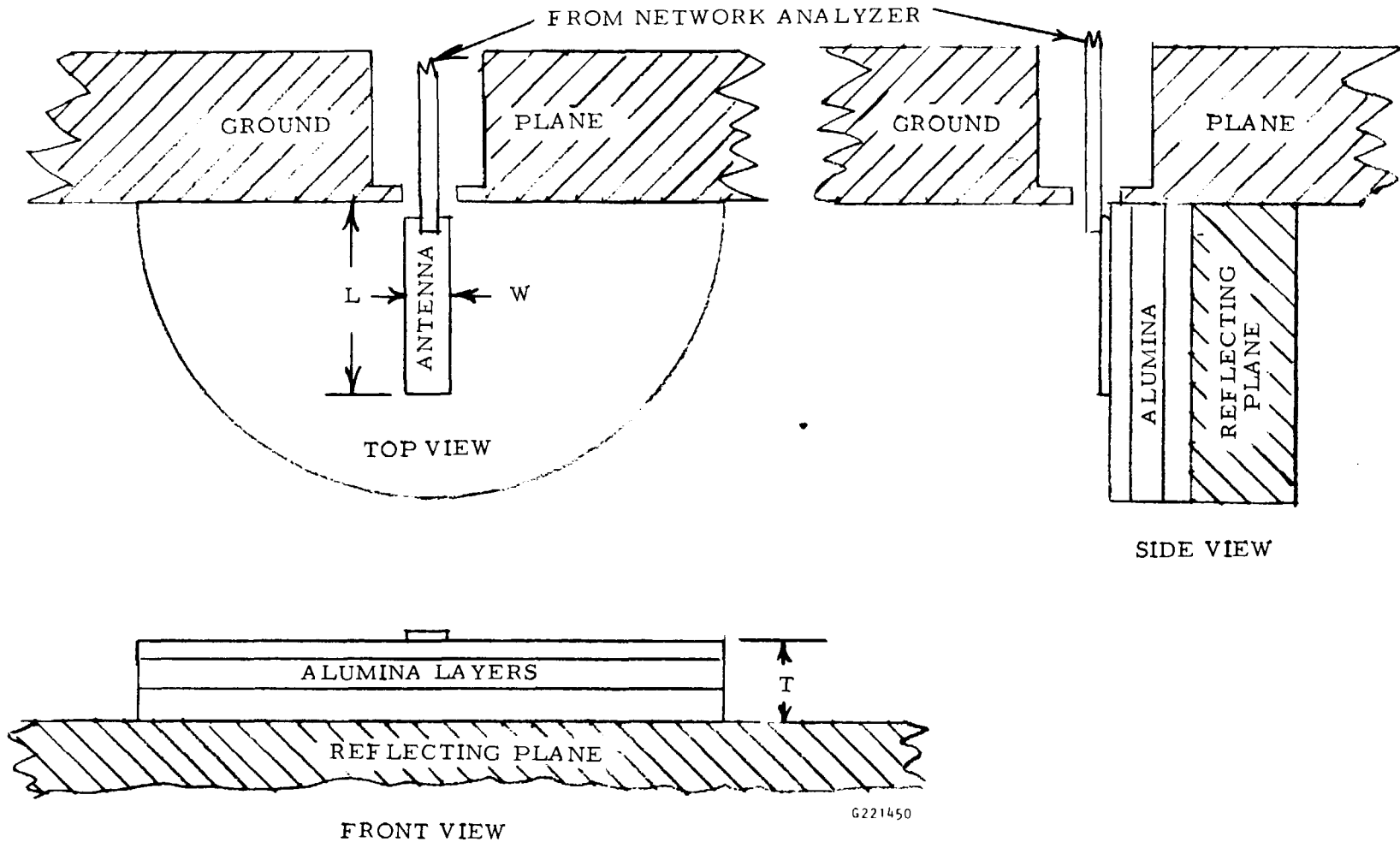

Figure 2-29. Test Arrangement for Matching a Rectenna Element Dipole that is Mounted on an Alumina Substrate to Space. The Rectenna Element is Split in Half by Means of a Ground Plane which Leaves the Characteristics of the Rectenna Element Unaffected Except for Halving the Characteristic Impedance. In this Manner, a Standard Network Analyzer can be Used to Make Measurements of the Match between the Element and Space.

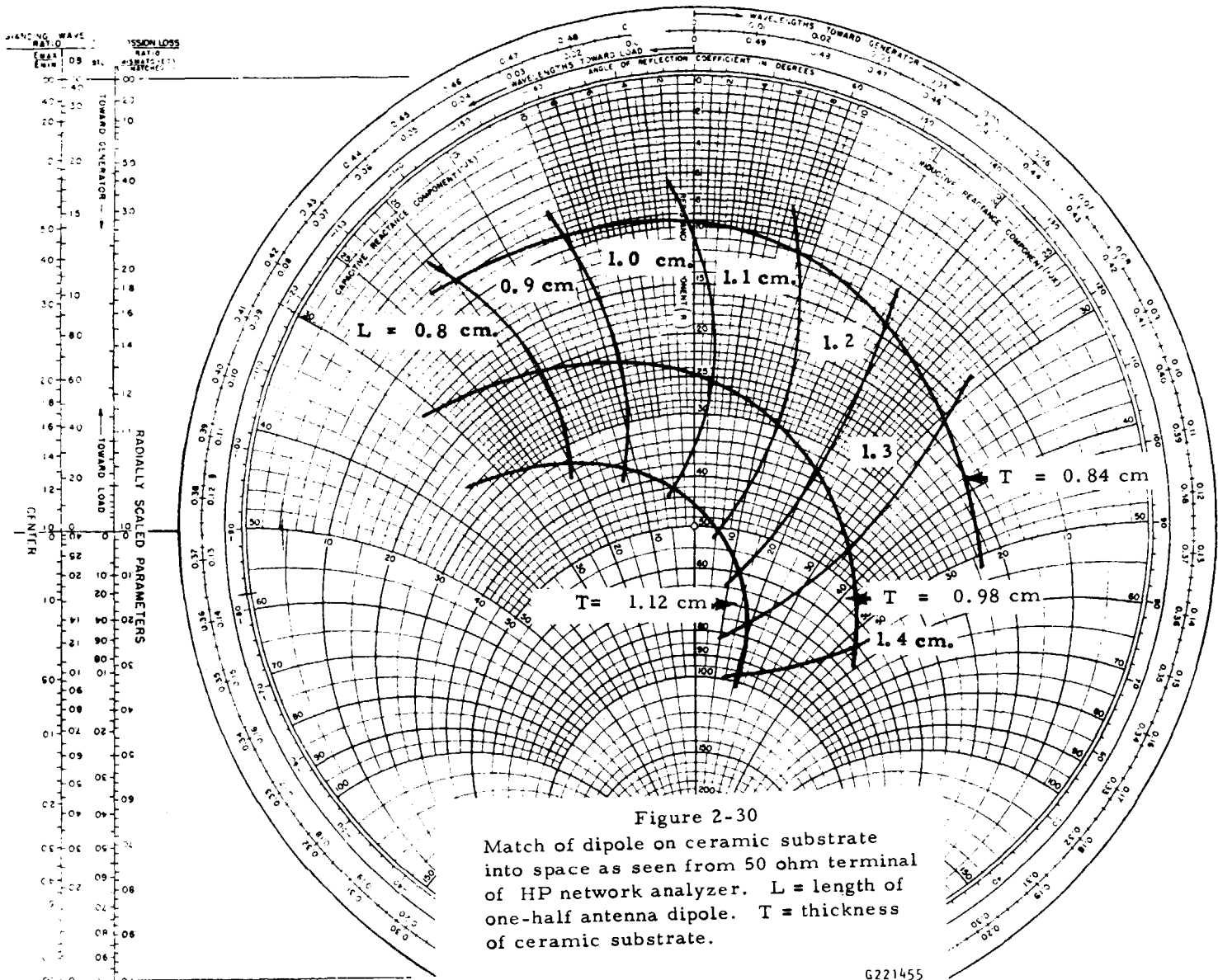

Figure 2-30
Match of dipole on ceramic substrate into space as seen from 50 ohm terminal of HP network analyzer. L = length of one-half antenna dipole. T = thickness of ceramic substrate.

G221455

1.05 cm and an alumina thickness of 1.12 cm. The length of the antenna at 2.45 GHz in the conventional thin-film, etched circuit rectenna described in Section 2.1 is 2.92 centimeters. The length is roughly shortened by a factor of 3, approximately the $1/2$ power of the dielectric constant.

2.7.4 Measurements of Match, Power Output, and Operating Efficiency of a 2.45 GHz Rectenna Element Mounted on a Ceramic Substrate

Having obtained a match between space and an antenna dipole mounted on alumina substrate it was of interest to place a rectenna element with its dipole mounted on ceramic within a closed system so that measurements of match and overall efficiency could be made. A thin-film, etched-circuit rectenna element was used for this purpose. To prevent the ceramic material from modifying the low pass filters in the thin-film, etched-circuit format, this portion of the microwave circuit was elevated 0.100" above the ceramic. The antenna, shortened in length as required, was mounted directly on the ceramic.

It would be expected that the ceramic mounted dipole would have a cell area within the rectenna array considerably less than would a dipole separated from a reflecting plane with only air or vacuum in between. It would therefore need a test fixture with a smaller cross section to simulate the cell area. This was, indeed, found to be the case. Three differently configured sources of incident microwave power were used. The first was the standard expanded 4.5 x 4.5 inch fixture; the second was standard 4.5 x 2.25 inch waveguide, and the third was standard 3 x 1.5 inch waveguide. Waveguide openings had waveguide flanges so that there was a minimum of microwave leakage to space.

A best match of 4.8 dB (7.2 percent reflected power) was obtained with the 4 1/2 x 2 1/4 inch waveguide source. The resistive load was 300 ohms; the DC power output was 0.848 watt, and the element efficiency was 80.3 percent. For this performance the total length of the antenna dipole was 2.8 cm.

Before more work of this nature is done, it is recommended that the low pass networks and other portions of the microwave circuit also be placed on the ceramic substrate.

3.0 DISCUSSION OF RESULTS

A discussion of results is naturally divided into two parts. One part is that having to do with the results of the work on the thin-film, etched-circuit rectenna at 2.45 GHz. The other part is that having to do with the extension of rectenna technology to the frequency of 20 GHz and above.

3.1 Discussion of Results of the Program to Develop a 2.45 GHz Thin-Film Etched-Circuit

The broad intent of this program was to upgrade the rudimentary work on a thin-film, etched-circuit rectenna under a previous contract having to do with a rectenna for a microwave powered airship and to direct its further development toward use in space. The results of the program were highly successful in those aspects covered by the program. However, there were several aspects that were not covered.

The major achievement was the rather dramatic upgrading of the power handling capability of the thin-film rectenna for both space applications and for suitable terrestrial applications such as microwave powered aircraft. This upgrading in power handling capability resulted from several improvements. The first was an improvement in efficiency, from 70 to 85%. Because this increase in efficiency halved the inefficiency losses, it doubled the DC power output capability for a given rectenna operating temperature. Moreover, the change from mylar to Kapton substrate that caused the efficiency improvement also made it possible to operate the dielectric substrate safely at a temperature of 200°C where the GaAs diode can safely operate. Although difficult to quantify, it is expected that ability to operate at a higher temperature added another factor of 2 to the power handling capability of the rectenna in space or elsewhere.

It was possible to partially evaluate the power handling capability under incident microwave radiation up to one kilowatt of DC power output per square meter under conditions of convective air cooling at sea level air density. At this point, the high impedance design of the rectenna element limited further data taking. However, the diode temperature rise was still less than 100°C and the air flow velocity was nominally low. The implication is that the rectenna element should be redesigned to a much lower impedance level to accommodate higher levels of power density which might be desired for terrestrial applications and for which the rectennas is basically capable. In fact, going back to the impedance level of the rectenna design that was used so successfully in the 1975 tests on the Mojave desert appears to be desirable.

The scope of the contract did not include any testing in vacuum. However, from theoretical work based on the same radiative geometry (reported in reference 1) and then upgraded by the use of a ceramic package for the diode, it would appear that a DC power density of 400 w/m², twice that of the conservative

value previously assigned to a space application, would be reasonable. It is obvious that it is important to obtain data on the rectenna while it is being operated in a vacuum environment.

The rectenna that has been developed under this contract appears to basically meet requirements for aircraft use as far as efficiency, power-handling requirements, and life are concerned. There is, inevitably, some harmonic radiation from the rectenna which may limit its initial acceptance. And, recently, it has been observed that the current thin-film rectenna design has internal parametric oscillations at a few hundreds of MHz that modulate the 2.45 GHz signal reflected from the rectenna. Such sidebands in the reflected signal are intolerable. Current investigations indicate that this is not a general property of rectennas and that the phenomenon can probably be removed from the present design.

For space applications of the rectenna there are additional considerations having to do with the space environment that were not examined. The rectenna is impacted in space by various forms of radiation. The change to Kapton for the dielectric substrate eliminates deterioration from ultra violet radiation as a consideration, but the diode may be susceptible to other forms of radiation. If there is deterioration of the diode from such radiation, it could probably be minimized by adding shielding to the diode on a scale which would not add materially to the overall mass of the rectenna. The rectenna should be evaluated in an environment that closely simulates space in all respects, or be tested in the space environment itself.

There may also be the problem of leakage current flow through plasma between high voltage terminals of the rectenna when the rectenna is operated at relatively low altitudes. There is divided opinion as to whether or not that would be a problem with the current rectenna. However, if it is a problem in the current rectenna design, the leakage current could be minimized by adding an additional dielectric film over the etched copper circuits, much as is done with commercial flexible copper circuits which are bonded between two Kapton films. It is difficult to image a high voltage build up across terminals of the rectenna and causing arcs. Regardless of the polarity of the charge build-up, the diode serves as a means of allowing that charge to leak off in either the forward conduction cycle or by exceeding the breakdown voltage in the reverse direction.

There are a number of issues related to the fabrication and cost of the thin-film, etched-circuit rectenna. They relate to both the fabrication of the etched-circuit and to the diode.

For any large scale application the fabrication of the rectenna must be a continuous flow operation with the laminate coming in at one end and the finished etched rectenna coming out the other. The laminate must also be made continuously with the copper foil and dielectric substrate flowing into the

laminating machine from spools of the material. Initial continuous systems may be limited, for initial cost consideration, to a single rectenna row.

The Kapton F laminate itself requires a high temperature press which is non-standard equipment in most fabrication shops. What is needed is an adhesive that has a low dielectric loss but which will bond copper to Kapton H. In this context, the space application demands a dielectric substrate with minimal loss, but aircraft applications could tolerate nominal losses associated with Kapton itself and also nominal losses in the adhesive.

The diode that is currently being used is an exceptionally high quality diode in many aspects. The internal losses are low; it will operate at a relatively high temperature; and heat is conducted readily away through the plated heat sink. The diode has been evaluated on life test. If purchased to the proper set of specifications the diode will give satisfactory service for many years. The major issue with respect to the diode is its cost. Although it is a basically simple device, the very low demand for the diode has kept it at a high price. Downstream, at some point, there should be a new diode packaging technique which will make the diode easier to fabricate and also make it quite thin so that the rectenna can be rolled up tightly.

3.2 Discussion of the Results of the 20 GHz Rectenna Investigation

This portion of the study focussed upon investigating approaches to the design and fabrication of a rectenna at 20 GHz. However, the findings of the investigation were expected to be applicable to rectennas at considerable higher frequencies.

It appears that the investigation of a high frequency rectenna and preliminary findings on the best way to construct it may be timely. The recent development of the gyrotron, a new microwave tube that can continuously deliver several hundreds of kilowatts of power at these high frequencies, permits the generation of very sharp beams with a moderate sized aperture which could be mounted on ships or land vehicles. Thus, in principle at least, the high frequency rectenna and gyrotron expand the range of applications for free space power transmission.

The investigation started out as a scale of the 2.45 GHz thin-film etched-circuit rectenna to 20 GHz. Various formats for the use of a thin dielectric film were examined in considerable detail. None, however, were without severe faults, so interest turned in the direction of using an alumina substrate and silk screened circuits - a technology in common use. Then the unavailability of suitable beam lead diodes, combined with the need for so many per unit area, and some concern about the difficulty of bonding the diodes to the circuits, motivated looking at the monolithic approach in which a semiconductor substrate is used and the diodes are built up on that substrate.

The monolithic approach was finally selected as the recommended approach for future development activity on high frequency rectennas. Further, GaAs was recommended over silicon as the substrate material because of its much better microwave properties, even though the quality of the substrate material needs upgrading, an activity that has now received priority because of the desire to use GaAs in other applications.

It was determined that a high frequency monolithic rectenna would require operation at a comparatively high power density to maintain an acceptable level of efficiency because of the Schottky barrier voltage becoming comparable to the output across the load and therefore representing a large loss. The power density for good efficiency will be in the 3 to 10 kilowatt per square meter range and the accompanying heat dissipation will be comparable, necessitating some form of convective cooling of the rectenna. This introduces a severe problem for space applications but one that can be tolerated for airborne applications where the higher power density may be wanted anyway.

Although the monolithic rectenna approach has been established as the direction in which to proceed with a high frequency rectenna development, it must be pointed out that the development will probably be a lengthy and costly one before production prototypes could become available. If such developments are started, there will undoubtedly be findings that will modify the initial design approach. For this reason, the initial monolithic rectenna development should be started as an exploratory venture. Total rectenna areas and associated power levels should be kept low to minimize the cost of test equipment, particularly the microwave generator which initially would be some other device than the gyrotron which is much too massive and expensive to use for laboratory work.

4.0 SUMMARY OF RESULTS

The scope of the activities carried out under this contract covered two activities whose objectives were distinctly different. The first of these objectives was the establishment of a thin-film, etched-circuit rectenna at 2.45 GHz that would be satisfactory for space operation. The second objective was investigating and establishing, if possible, suitable technologies for constructing rectennas at very high frequencies of 20 GHz and above.

A summary of the results of the work effort is logically divided according to these two different objectives.

4.1 Summary of Results to Improve the Thin-Film, Etched-Circuit Format of the Rectenna and to Adapt it to Space Use

1. In response to a need to determine why the early approach to a thin-film rectenna employing mylar was not satisfactory, special measurement tools were developed and used to determine precisely the dielectric constants and loss tangents of the mylar material and the loss properties of the adhesive material used to bond the mylar to the copper microwave circuits.

2. These measurement tools indicated that the published data on the dielectric constant and loss tangent for mylar were in error by a considerable factor and that our measurements were consistent with the poor behavior of the rectenna element. In the course of investigating the source for this published error, it was found that the correct values for mylar had been subsequently published in a relatively obscure report, thus corroborating our findings.

3. In the course of investigating more suitable materials for the dielectric film it was also found that Kapton had much better characteristics than those that had been published. This finding was based upon our experimental measurements and other information sources. It was decided to redesign the rectenna based upon the use of Kapton.

4. Experiments in bonding Kapton to copper were carried out to create the needed laminate material. Kapton does not bond directly to copper, so the industry has created a film material that uses Kapton as the core material with Teflon sealed to it. The teflon does bond to copper at suitably high temperatures. Our experiments determined that a one mil Kapton core with one half mil of teflon on both sides was a suitable film material.

5. The laminated material with copper on both faces was not available commercially and it was necessary to make the laminated material using special facilities at one of the Raytheon facilities.

6. Using the special laminated material, a rectenna element design was evolved and suitable masks for the etching process were made. The art work involved three successive reiterations, and took into account a rather drastic change in the design of the Schottky barrier diode.

7. A sequence of diode fabrication considerations as well as a trend toward a higher power density rectenna led to a change in packaging the diode from a glass to a ceramic pill package, and in increasing the size of the diode junction by a factor of three.

8. Measurements on the final design of the rectenna element that were made in a closed system, where accurate measurements of efficiency could be made, gave values of 85% with an estimated probable error of $\pm 1.5\%$. These efficiencies are only 5% less than the best achieved with the rigid, much heavier, and much more costly bar type rectenna construction. This 85% efficiency contrasts with the 70% efficiency of the mylar based element. Because any inefficiency in a space rectenna results in heat that has to be radiated to space, the improved design generates less than half as much heat for a given DC power output of the rectenna.

9. Based upon the design of the individual rectenna element, masks were made for rectenna sections containing 25 elements. Diodes were bonded to these sections. These sections were then mounted on a special fixture for evaluating their performance when immersed in an incident microwave beam of sufficiently large cross section to provide nearly uniform illumination of the rectenna section.

10. Nearly 120 watts (five watts per diode) were obtained from these sections at an estimated efficiency of 85%. The diode temperature rise for this power level was only 50°C .

11. For these tests, a new procedure utilizing the fluoroptic thermometer was evolved to determine the temperature of the diode and other parts of the rectenna element while it was being subjected to various levels of convective air cooling and incident microwave power. The fluoroptic thermometer permits non-invasive measurements of diode and circuit temperatures because it does not interact with the microwave field in any manner and because its thermal capacity and thermal conduction are negligible.

12. A very important achievement of the program was the introduction of a method of testing the efficiency and power handling capability of the rectenna element without resorting to the measurement of the microwave power input. This achievement arose from the fact that the fluoroptic thermometer makes it possible to determine the temperature of the diode, the critical factor in determining an upper limit on the elements' power handling capability, as a function of velocity of cooling air flowing over the surface of the balance of the rectenna element which serves as a cooling radiator for the diode as well as for heat generated elsewhere. Furthermore, the diode temperature for a given air flow can be observed as a function of the power dissipated within the diode resulting from the injection of carefully measured dc power. But when the diode is behaving as a microwave rectifier, diode inefficiency results in heat being generated in the same spot within the diode. This equivalence of heat sources allows the use of information obtained from observing temperature

rise with injection of DC power to determine power being dissipated within the diode when the rectenna element is absorbing microwave radiation and causing the diode temperature to increase. From this equivalence, the rectenna element efficiency can be closely approximated by the formula:

$$\text{Rectenna Element Efficiency} \approx \text{Diode Efficiency} = \frac{\text{DC Power Out}}{\text{DC Power Out} + \text{Diode Dissipation}}$$

The rectenna element efficiency approximates diode efficiency because the diode generates about 80% of the inefficiency and heat within the complete rectenna element. Further, the non-diode circuit losses are greatest in the region of the diode and tend to also raise the temperature of the rectenna element as measured at the diode.

13. The efficiency of individual rectenna elements measured with this technique closely checked those made in a closed system where the microwave power was carefully measured. The new method has the great advantage of allowing simultaneous measurements of efficiency and diode temperature rise while measurements of convective air flow are also being made under conditions that simulate, for example, those found in the application of the rectenna to a wing of an airplane. Such conditions would be difficult to simulate in a closed system for checking a rectenna.

14. Using this new test procedure, we were able to determine the dissipation power occurring within the diode as a function of the measured temperature rise on the case of the diode and of the air flow velocity at sea level pressure. Then, with a reasonable assumption for the efficiency of the diode and corresponding rectenna element, projections could be made of the DC power output density of the rectenna for acceptable diode temperature rise and convective cooling practices.

15. Under the assumption that it is the mass of air flow, or air velocity times density, that determines the amount of cooling, the results obtained at sea level can be transferred to high altitude where the air density is much less but the velocity of air flow may be much greater, for example, in the application to an airplane wing.

4.2 Summary of Results to Develop a Technology for Constructing Rectennas at Frequencies of 20 GHz and Above

1. An important result, after a thorough effort to adapt the thin-film, etched-circuit rectenna technology to a high frequency rectenna, was the conclusion that it would be very difficult to adapt the technology.

2. However, as part of this effort, the interdigital finger technique was introduced to allow lumped capacitances to be formed on one side of the film only. This technique was later applied to thick dielectric substrates.

3. The tentative move to the use of alumina ceramic as both a substrate for the circuit and as the dielectric filler between the foreplane and reflecting plane. In this conceptual arrangement the microwave circuit, with interdigital fingers for capacitors, would be silk screened onto the ceramic. The diodes were visualized as beam-lead devices that were compression bonded to the silk screened circuits.

4. A final move to a monolithic rectenna that used GaAs as a substrate for the microwave circuits and as a base for the integral Schottky barrier diodes.

5. The design of the diode itself, together with a reasonable estimate of its power handling capability as determined by its efficiency and ability of the substrate to conduct heat to the reflecting plane. A quantitative analysis of heat flow was made.

6. The estimate that the power handling capability in terms of DC power output density should be in the range of 3 to 10 kilowatts of DC power per square meter.

7. The development of an experimental approach to matching the rectenna element, when placed on a ceramic (or semiconductor) substrate, to space. It was possible to make the match by greatly reducing the dimensions of the half-wave dipole. The work was carried out at 2.45 GHz but can be scaled to the very high frequencies of interest.

8. The single dipole on its ceramic substrate, attached to the balance of a thin-film, etched-circuit rectenna element, was evaluated for efficiency in a closed system using waveguide and found to exhibit normal, high efficiency.

REFERENCE

1. W.C. Brown, "Design Definition of a Microwave Power Reception and Conversion System for Use on a High Altitude Powered Platform", NASA Contractor Report CR-15866, Contract NAS6-3006, Wallops Flight Facility.
2. W.C. Brown, J.F. Triner, "Experimental Thin-Film, Etched-Circuit Rectenna", 1982 IEEE MTT-S International Microwave Symposium Digest, IEEE Cat. No. 82CH1705-3.
3. W.C. Brown, "Performance Characteristics at the Thin-Film, Etched-Circuit Rectenna", 1984 IEEE MTT-S International Microwave Symposium Digest.
4. W.C. Brown, "The History of Power Transmission by Radio Waves," Trans. on Microwave Theory and Techniques, Vol. MTT-32, No. 9, Sept., 1984. Special Centennial Historical Issue.
5. W.C. Brown, "The History of the Development of the Rectenna", Presented at the RECTENNA SESSION OF THE SPS MICROWAVE SYSTEM WORKSHOP, Jan. 15-18, 1980, L.B. Johnson Space Center, Houston, Texas.
6. W.C. Brown, "Electronic and Mechanical Improvement of the Receiving Terminal of the Free-Space Microwave Power Transmission System", NASA Report CR-1135194, Raytheon PT-4964, August 1, 1977, Contract NAS 3-19722.
7. W.C. Brown, "Solar Power Satellites: Microwaves Deliver the Power", IEEE Spectrum, June, 1979, pp. 36-42.
8. W.C. Brown and P.E. Glaser, "An Electrical Propulsion Transportation System from Low-Earth Orbit to Geostationary Orbit Utilizing Beam Microwave Power", given at the Symposium on Energy from Space at the United Nations' Conference on the Exploration and Peaceful Uses of Outer Space, Vienna, Austria, August, 1982. Paper published in Space Solar Power Review, Vol. 4, pp. 119-129, 1983.
9. S.M. Sze, Physics of Semiconductor Devices, Wiley-Interscience, a Division of John Wiley and Sons, New York, 1969.

END
DATE

MAY 27, 1987

